



Appalachian Underground Corrosion Short Course

Basic Course

Appalachian Underground Corrosion Short Course
West Virginia University
Morgantown, West Virginia

Copyright © 2019

**APPALACHIAN UNDERGROUND CORROSION SHORT COURSE
BASIC COURSE**

CHAPTER 1 - BASIC ELECTRICITY	1-1
INTRODUCTION	1-1
ELECTRICAL FUNDAMENTALS	1-1
Physical Matter	1-1
The Two General Types of Electricity	1-2
BASIC TERMS	1-3
OHM'S LAW	1-9
THE BASIC ELECTRICAL CIRCUIT	1-12
THE SERIES ELECTRICAL CIRCUIT	1-13
THE PARALLEL ELECTRICAL CIRCUIT	1-15
COMBINATION CIRCUITS	1-18
 CHAPTER 2 - CORROSION FUNDAMENTALS	 2-1
INTRODUCTION	2-1
FUNDAMENTAL CORROSION CELL	2-2
TYPES OF GALVANIC AND NATURAL CORROSION	2-4
Dissimilar Metals	2-4
Dissimilar Surfaces	2-5
Dissimilar Soils	2-6

Differential Aeration	2-7
Stress Corrosion	2-7
Cast Iron Graphitization	2-8
Microbiologically Influenced Corrosion	2-9
Combinations of Corrosion Cell Effects	2-10
Amphoteric Metals	2-10
STRAY CURRENT CORROSION	2-10
Definition of Stray Current Corrosion	2-10
Differences Between Stray Current Corrosion and Galvanic and Natural Corrosion	2-11
Severity of Stray Current Corrosion	2-11
Why Stray Current Occurs	2-11
Alternating Current	2-11
Types of Stray Current Corrosion	2-12
Sources of Stray Current Corrosion	2-12
Typical Static Stray Current Sources	2-13
HVDC Systems	2-14
Typical Dynamic Stray Current Sources	2-15
DC Transit Systems	2-15
DC Mining Operations	2-16
DC Welding Operations	2-17

FACTORS AFFECTING THE RATE OF CORROSION	2-17
General	2-17
Polarization	2-18
Electrolyte Resistivity	2-18
Voltage Difference Between Anode and Cathode	2-19
Anode/Cathode Ratio	2-19
Effect of the Metal Itself	2-19
Passivation of the Metal Surface	2-20
SUMMARY	2-20
 CHAPTER 3 - CORROSION CONTROL METHODS	 3-1
INTRODUCTION	3-1
SUMMARY OF CORROSION CONTROL METHODS	3-1
COATINGS	3-1
CATHODIC PROTECTION	3-4
Theory of Cathodic Protection	3-4
How Cathodic Protection Works	3-4
Types of Cathodic Protection	3-6
Galvanic (or Sacrificial) Anode Cathodic Protection	3-7
Impressed Current Cathodic Protection	3-8
ISOLATING JOINTS	3-10

DRAINAGE BONDS	3-11
REVERSE CURRENT SWITCHES	3-11
FORCED DRAINAGE BONDS	3-12
CHAPTER 4 - INTRODUCTION TO PIPELINE COATINGS	4-1
INTRODUCTION	4-1
General	4-1
Laboratory Coating Tests	4-1
Electrical Inspection of Coatings	4-2
Surface Preparation Standards	4-2
PLANT APPLIED COATINGS	4-3
General	4-3
Fusion Bonded Epoxy	4-3
Extruded Polyethylene	4-3
Coal-Tar Enamel and Asphalt Enamel	4-4
Liquid Epoxy	4-4
Other Plant Applied Coatings	4-4
FIELD APPLIED COATINGS	4-4
General	4-4
Hot-Applied Tape	4-5
Cold-Applied Tape	4-5

Heat-Shrink Sleeves	4-6
Fusion Bonded Epoxy	4-7
Liquid Epoxy	4-7
Maintenance Coatings	4-8
Coating of Exposed Pipelines	4-8
High Temperature Coatings	4-9
Coating of Flanges and Flange Bolts	4-9
CONCLUSION	4-10
CHAPTER 5 - POTENTIAL MEASUREMENTS	5-1
INTRODUCTION	5-1
INSTRUMENTATION	5-1
Voltsmeters	5-1
Effect of Voltmeter Resistance on Potential Being Measured	5-2
Care and Storage of Instruments	5-5
REFERENCE ELECTRODES	5-5
Electrode-to-earth Resistance	5-8
STRUCTURE-TO-EARTH POTENTIAL MEASUREMENTS	5-9
CELL-TO-CELL POTENTIAL MEASUREMENTS	5-12
STRUCTURE-TO-STRUCTURE POTENTIAL MEASUREMENTS	5-13
POTENTIAL SURVEYS	5-16

POLARIZATION EFFECTS ON POTENTIAL	5-20
CRITERIA FOR CATHODIC PROTECTION	5-20
MONITORING CATHODIC PROTECTION SYSTEMS	5-21
CHAPTER 6 - RESISTANCE AND CURRENT MEASUREMENTS	6-1
INTRODUCTION	6-1
RESISTANCE MEASUREMENTS	6-1
Introduction to Resistance	6-1
Measuring a Simple Resistance	6-1
Delta Values in Resistance Tests	6-2
Resistance of Electrical Isolation Devices	6-3
Resistance-to-Earth of Pipelines and Anode Beds	6-4
Resistance of a Pipeline Span	6-5
SOIL RESISTIVITY MEASUREMENTS	6-5
What is Soil Resistivity?	6-5
Soil Resistivity and Corrosivity	6-5
Measuring Soil Resistivity	6-6
Soil Box Procedure	6-6
Single Rod Test Procedure	6-7
Wenner Four Pin Method	6-8
CURRENT MEASUREMENTS	6-9

Introduction to Current	6-9
Measuring Current with a Shunt	6-10
Measuring Current Flow on a Pipeline	6-11
Measuring Current with an Ammeter	6-13
Clamp-On Ammeters	6-13
CHAPTER 7 - RECTIFIERS BASICS	7-1
INTRODUCTION	7-1
RECTIFIER SAFETY	7-1
RECTIFIER COMPONENTS	7-1
What is a Rectifier?	7-2
Transformer	7-2
Circuit Breakers	7-3
Shunts	7-3
Accessory Equipment	7-3
TYPES OF RECTIFIERS	7-4
Air Cooled Rectifiers	7-4
Oil Cooled Rectifiers	7-4
Explosion Proof Rectifiers	7-5
Constant Current Rectifiers	7-5
Automatic Potential Controlled Rectifiers	7-5

PERIODIC RECTIFIER INSPECTIONS	7-5
Inspecting Rectifiers	7-5
Remote Monitoring of Rectifiers	7-6
Prior to Touching Rectifier Case	7-6
Measuring Rectifier Voltage	7-6
Measuring Rectifier Current	7-7
Preventive Maintenance	7-7
Basic Troubleshooting	7-8
INTERRUPTING A RECTIFIER	7-8
CHAPTER 8 - REGULATORY COMPLIANCE	8-1

April 7, 2019 Revision

To submit comments, corrections, etc. for this text, please email:
curriculum@aucsc.com

COPYRIGHT NOTICE:

All content on the Appalachian Underground Corrosion Short Course (AUCSC) web site is protected by copyright of AUCSC and may not be reproduced, duplicated or distributed without the express written permission of AUCSC.

The Fundamentals, Basic, Intermediate and Advanced textbooks may be reproduced only as single copies for study and review only by an individual solely for his or her own use who personally and directly downloads the document from the AUCSC website.

Chapter 1 - Basic Electricity

INTRODUCTION

In this chapter, we will be discussing:

- the kinds of electricity encountered in corrosion control work
- explanations of various applicable electrical terms
- how the electrical units represented by these terms interact
- how the electrical units apply to various types of electrical circuits.

It is important that the principles set forth in this chapter be thoroughly understood before proceeding to the material included in the remaining chapters of the Basic Course. Similarly, a complete knowledge of this chapter will be at least equally as important to an understanding of the subject matter included in the Intermediate and Advanced Courses.

The treatment of the subject material in this chapter is intended to be such that a good practical understanding will result. This in turn permits a better understanding of the logic and mechanics of interpreting, evaluating and solving corrosion problems when encountered in the field.

ELECTRICAL FUNDAMENTALS

Physical Matter

Electricity is directly involved with the makeup of physical matter. Although we will not spend a great deal of time on atomic structure of matter, we need to explore the subject sufficiently to establish the stated relationship between matter and electricity.

What is "Matter"

"Matter" is that which makes up the substance of anything. It will occupy space and will have mass. It can be a solid, a liquid, or a gas. Whatever the form may be, however, it will be made up of atoms or of atoms and/or molecules. Atoms are the building blocks from which elements are comprised - an element being that form of matter which cannot be changed by chemical means. Examples of elements are copper (chemical symbol Cu) and oxygen (chemical symbol O). Molecules are combinations of atoms that comprise the smallest part of a substance that retains the physical characteristics of that

substance. An example of a molecule would be the smallest part of copper sulfate (CuSO_4) which is a combination of atoms of copper (Cu), sulphur (S), and oxygen (O).

When we take a closer look at atoms, we find that they are made up of a positively charged nucleus surrounded by orbiting negatively charged electrons. Each elemental atom has its own characteristic combination of a nucleus and electrons. Electrons are the key word insofar as the relationship with electricity is concerned. A flow of electric current involves the transfer of electrons through an electrical circuit.

This relationship will be explored in greater detail in Chapter 2 - Corrosion Fundamentals.

The Two General Types of Electricity

There are two general types of electricity which will be involved with corrosion and corrosion control work. These are alternating current (AC) and direct current (DC).

Alternating Current (AC)

Alternating current electricity is that which flows first in one direction and then in the opposite direction in accord with an established pattern. As an example, the usual alternating current power sources used in the United States have a frequency of 60 cycles per second. This is referred to as 60 Hertz (or 60 Hz). A single cycle can be illustrated as shown in Figure 1-1.

As can be seen from the figure, the current flow at the beginning of the cycle (left side of illustration) is zero. The current builds up to a peak in the forward direction and then drops back to zero at the end of the first half cycle. It then reverses its direction of flow and builds up to a maximum in the reverse direction. Following this, it again drops back to zero at the end of the second half cycle (which is the end of one full cycle). At this point, it again reverses direction to start the next cycle.

From this, it can be seen that there are, in effect, two net current reversals for one full cycle. This means that for a normal 60 Hz alternating current power source, the current flow changes direction 120 times per second.

The shape of the normal current flow plot from the usual alternating current commercial power source is known as a sine wave.

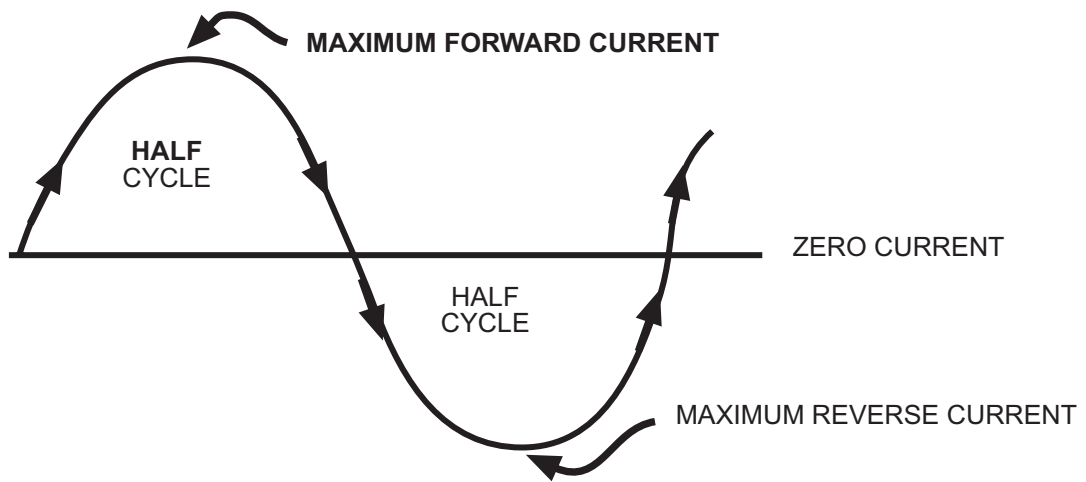

ALTERNATING CURRENT (AC) SINE WAVE

FIGURE 1-1

Significance of Alternating Current

Alternating current electricity is a relatively insignificant factor as a cause of corrosion except in very special cases.

In the control of corrosion, however, commercial AC power sources are used as an energy source to power corrosion control equipment such as rectifiers (which convert AC power to DC power) widely used in impressed current cathodic protection systems. These are discussed in Chapter 3 - Corrosion Control Methods.

Direct Current (DC)

Direct current electricity is that which normally flows in one direction only rather than changing direction in accord with an established pattern as was discussed for alternating current.

An example of direct current is that from a battery powering a common flashlight.

Significance of Direct Current

DC electricity is of prime importance in the consideration of the corrosion process. It is directly involved in the various types of corrosion cells discussed in Chapter 2, "Corrosion Fundamentals." It is also directly involved in corrosion control by the use of various types of cathodic protection as discussed in Chapter 3.

In this chapter, the prime emphasis will be on electrical fundamentals as they apply to DC circuits.

BASIC TERMS

The following discussion defines and explains the various electrical units and terms which are involved in DC electrical circuits. A thorough understanding of these is necessary in order that various types of electrical circuits encountered in corrosion work may be properly analyzed and evaluated. Once the meaning and use of these units and terms are mastered, they will be used in understanding the various sample calculations used throughout the balance of the Basic Course. Further, they will allow knowledgeable handling of the various types of DC circuits and conditions when encountered in the actual practice of detecting, evaluating and solving corrosion problems in the field.

Volt

The volt is the basic unit of electrical pressure which forces an electrical current (electrons) to flow through an electrical circuit. Voltage can be used to indicate electrical pressure in general. The comparable term in a water system would be water pressure expressed as pounds per square inch (psi).

Another term used for electrical pressure is electromotive force or EMF. Still, the volt is the unit used to express the quantitative amount of an electromotive force.

The symbols representing electrical pressure in formulas which you may use in corrosion work will be either V (for volts) or E (for EMF -- which is also voltage).

Although 1 volt is the basic unit, there are instances where much smaller units are easier to use. One millivolt (mV or mv) is one thousandth of a volt, or:

$$1000 \text{ mV} = 1 \text{ V}$$

$$1 \text{ mV} = 0.001 \text{ V}$$

Also, one microvolt (μV or μv) is one millionth of a volt, or:

$$1,000,000 \mu\text{V} = 1 \text{ V}$$

$$0.1 \mu\text{V} = 0.000001 \text{ V}$$

Sources of DC voltages encountered in corrosion work include corrosion cell voltages which cause corrosion current to flow (see Chapter 2). Such voltages are typically in the millivolt or microvolt range. In some instances, stray current corrosion (caused by interference from outside sources as discussed in Chapter 2) can be caused by DC voltages measured in volts.

In corrosion testing work, DC voltages used as a source of test current may be batteries, such as common dry cell batteries or storage batteries. A flashlight battery typically has a voltage of nominally 1.5 volts while a storage battery of the automobile type has a voltage of nominally 12 volts. Where larger amounts of current are needed, DC generators may be used.

In corrosion prevention work, sources of DC voltage used to provide cathodic protection

current include:

- galvanic anodes of zinc, aluminum or magnesium where the driving voltage may be measured in tenths of a volt or in millivolts
- higher capacity sources such as AC to DC rectifiers or DC generators of various types. Such sources typically have output voltages measured in volts and are available in a wide range of voltages to match specific requirements.

All of the above are more fully discussed in Chapter 3 - Corrosion Control Methods.

Ampere

The ampere (often abbreviated to amp) is the basic unit of electrical current flow. This current is caused to flow through an electrical circuit by electrical pressure (or voltage) as discussed above. The comparable term in a water system to express the rate of water flow could be, for example, gallons per hour.

The symbol commonly used to represent current in formulas is the letter I. However, a calculated or measured current can be designated by the letter A; such as 12 A to represent 12 amperes. Typical applications will be discussed later in this chapter.

Although 1 ampere is the basic current flow unit, there are instances where very small fractions of an ampere may be involved in corrosion work. Smaller units may then be more convenient to work with. One milliamp (mA or ma) is one thousandth of an ampere, or:

$$1000 \text{ mA} = 1 \text{ A}$$

$$1 \text{ mA} = 0.001 \text{ A}$$

For an even smaller unit, one microamp (μA or μa) is one millionth of an ampere, or:

$$1,000,000 \mu\text{A} = 1 \text{ A}$$

$$1 \mu\text{A} = 0.000001 \text{ A}$$

Knowledge of current flow, its evaluation, and its measurement is particularly important in corrosion work since, as will be discussed in Chapter 2, there is a direct relationship

between the amount of current flow in a corrosion cell and the amount of corrosion experienced. The higher the current flow in a corrosion cell, the greater the amount of metal loss.

Coulomb

The term coulomb is seldom, if ever, encountered in practical corrosion control work on underground structures. It is, however, related to current. Earlier, in the section on "Physical Matter", it was indicated that electrical current flow involves a transfer (or flow) of electrons through an electrical circuit. The coulomb is a representation of this electron flow and is the basis for the practical unit, the ampere. A DC ampere is a flow of one coulomb per second where the coulomb is 6.28×10^{18} electrons. Another way of saying it is that the coulomb is 6.28 billion billion electrons -- a very large figure indeed.

The development of the coulomb is based on the fact that when normal (or neutral) atoms of a material either gain or lose electrons, they will develop positive or negative charges. When this condition exists, like charges repel each other and unlike charges attract each other. This attraction or repulsion force is the source of electrical pressure, or voltage, as discussed earlier. Then when a suitable current path is established, there will be a transfer of electrons between dissimilarly charged materials to satisfy a natural tendency to reestablish neutrality. This effect will be seen in Chapter 2 which discusses corrosion fundamentals.

Although, as indicated earlier, you may not use the term coulomb in your normal corrosion work, the above information is included here as background material to give greater meaning to the practical term "ampere." You can see the close relationship to the water system comparison mentioned in the section "ampere" where water flow could be indicated as gallons per hour rather than electrons per second for DC electricity.

Ohm

The ohm is the basic unit for resistance to the flow of electrical current. With a fixed driving voltage applied to an electrical circuit, the amount of current flowing through the circuit decreases as the circuit resistance increases. Conversely, the current flow increases as the circuit resistance decreases.

The usual symbol for resistance in formulas is the letter R. A calculated or measured figure for resistance may be represented by "ohms" or by the Greek letter omega (Ω);

for example, 10 ohms or 10 Ω .

Resistivity

The term resistivity is used to indicate the characteristic ability of a material to conduct electricity. It can be applied to both metallic and non-metallic materials.

Resistivity is commonly expressed as ohm-centimeters (ohm-cm). The unit ohm-cm is the resistance between opposite faces of a cube of material which is 1 centimeter x 1 centimeter x 1 centimeter in size. In practice, a cubic centimeter of a material is never isolated for the purpose of measuring its resistivity. Rather, the resistance across a body of the material of known dimensions is measured and, by calculation, determining its unit resistivity. See Chapter 5 for further information.

In underground corrosion control work, the greatest need for measuring resistivity is in connection with soils and waters as needed for the design of corrosion control systems.

Polarity

The term polarity is important in determining the direction of conventional current flow in practical usage. The direction of conventional current flow in DC circuits is from positive (+) to negative (-). If for example, a 12-volt battery is connected to an electrical circuit, electric current will flow in the conventional sense from the positive (+) terminal of the battery through the circuit and back to the negative (-) terminal of the battery.

In Chapter 2, it will be demonstrated that the flow of electrons (which actually is the basis for electric current as described earlier in this chapter under the heading "coulomb") is from minus (-) to plus (+) which is in the opposite direction from conventional current flow. Although it is important to know this, conventional current flow will be used in the great majority of practical corrosion control applications.

Conductor

The term conductor is used to designate a member of an electrical circuit that readily carries an electrical current. This will commonly be used to mean a wire or cable although in underground corrosion control work, pipes or other metallic structures may serve as conductors.

Different metallic materials have different capability for carrying electric current. This

is related to the characteristic resistivity of the material as has been discussed earlier.

Table 1 compares the relative current carrying capability of some conductor materials commonly encountered in underground corrosion work based on copper.

TABLE 1
Relative Conductivity of Some Metals
(Based on Smithsonian Physical Tables)

Material	Current Conducting Capability Based on Copper as 100%*
Copper (annealed)	100.0%
Aluminum	60.0%
Magnesium	36.8%
Zinc	27.6%
Brass	24.6%
Steel	9.6%
Lead	8.0%

*Relative percentages will vary depending on alloying components.

Although copper is obviously the best conductor material, a steel pipe (even though a relatively poor conductor material) can be a very good practical conductor because, particularly in larger sizes, the amount of steel in the pipe is so much greater than the amount of copper in the usual copper wire or cable. For example, the resistance of 1000 feet of 4/0 American Wire Gage (AWG) copper cable (which is approximately 0.54 inches in diameter) will have a resistance in the order of 0.051 ohms whereas the resistance of 1000 feet of 12-inch steel pipe with 0.375-inch wall thickness will have a resistance of only about 0.0058 ohms - - or roughly one tenth that of the heavy copper cable.

Insulator

An insulator or insulating material will have a very high resistance to the flow of electrical current and is used to confine or control the flow of current in electrical circuits. Examples are wire or cable jackets of rubber, neoprene, plastic or similar

insulating materials. On underground pipelines, insulating coatings of plastics, coal tar enamel, asphalt, and similar materials are used to restrict the flow of current to or from the earth.

Insulating materials are also used to electrically isolate one metallic structure from another. When insulating materials are used for this purpose they are called isolators or isolating devices.

How the Various Terms Go Together

In order to get a better idea of how the various terms described above are used in a simple electrical circuit, Figure 1-2 illustrates first the electrical usage and, for comparison, shows a water system analogy.

OHM'S LAW

The worker in the field of underground corrosion control must have a thorough understanding of Ohm's Law as it applies to DC circuits. Actually, the law is a very simple statement of the relationship between volts, amperes and ohms in a DC circuit.

Basically, the law states that one volt of electrical pressure will force one ampere of current through a circuit having a resistance of one ohm. This can be shown by the following formula:

$$E = I \times R$$

or

$$\text{Volts} = \text{Amps} \times \text{Ohms}$$

Using the formula as shown above allows us to calculate the voltage applied to a circuit if the current flow and circuit resistance are known. For example, if we know that the current flowing through a circuit is 3.6 amps and the resistance of the circuit is 1.7 ohms, the voltage needed to cause the 3.6 amps to flow will be:

$$E = I \times R$$

$$\text{Volts} = 3.6\text{A} \times 1.7\Omega = 6.12 \text{ V}$$

The Ohm's Law formula is flexible in that if any two components are known, the other

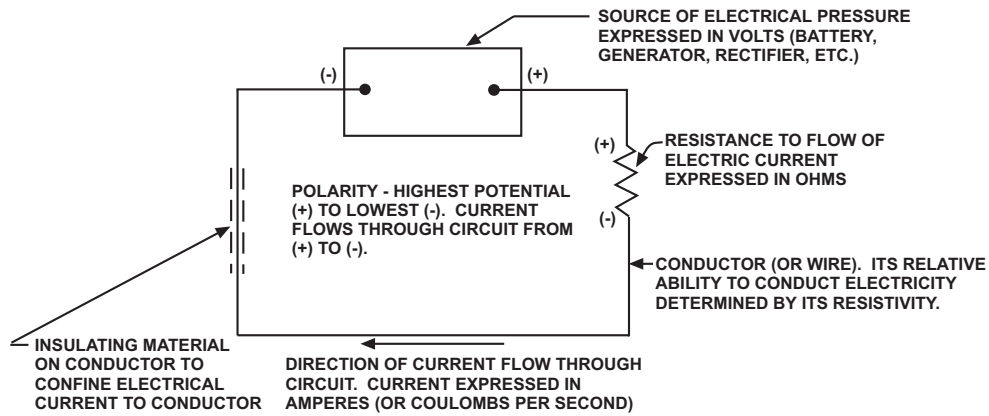

THE ELECTRICAL CIRCUIT

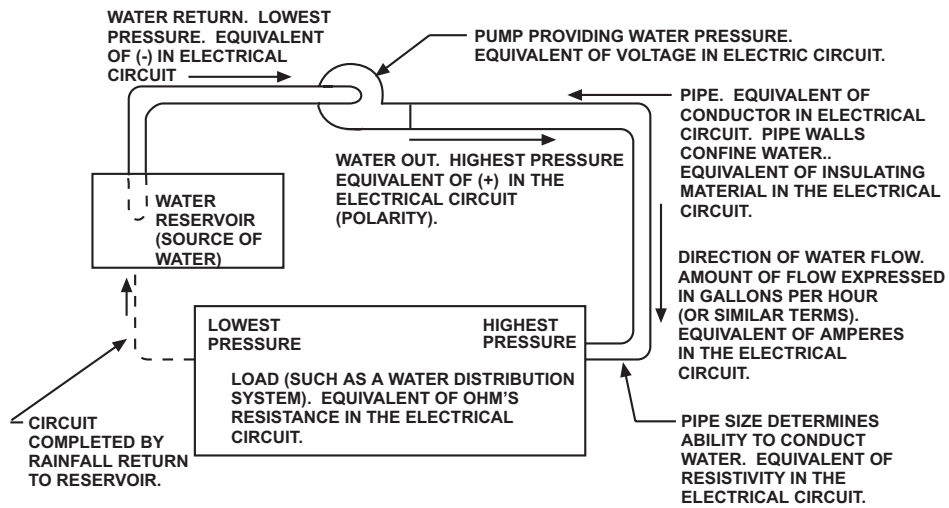

A WATER SYSTEM COMPARISON

COMPARISON OF ELECTRICAL CIRCUIT WITH A WATER SYSTEM CIRCUIT

FIGURE 1-2

can be calculated.

We have just covered the case where the voltage is the unknown component. Now consider the case where the current (I) is unknown while the voltage (E) and the resistance (R) are both known. To cover this, the formula is rearranged to:

$$I = \frac{E}{R}$$

or

$$\text{Amps} = \frac{\text{Volts}}{\text{Ohms}}$$

As an example of the use of this form of the formula, assume that a voltage of 12.0 volts is applied to a circuit having a resistance of 3.5 ohms. Calculate the current flow by using the formula as just stated.

$$I = \frac{E}{R}$$

or

$$\text{Current} = \frac{12\text{V}}{3.5\Omega} = 3.42\text{A}$$

There is one more form of the statement of the Ohm's Law formula to cover the case where the circuit current and applied voltage are known but the circuit resistance is unknown. The formula is rearranged to:

$$R = \frac{E}{I}$$

or

$$\text{Ohms} = \frac{\text{Volts}}{\text{Amperes}}$$

As an example, assume that 6.0 volts is applied to a circuit and that this forces 1.5 amps to flow through the circuit. Calculate what the circuit resistance must be to restrict the current flow to the 1.5 amps.

$$R = \frac{E}{I}$$

or

$$\text{Resistance} = \frac{6 \text{ Volts}}{1.5 \text{ Amps}} = 4 \text{ Ohms}$$

Ohm's Law is simple and easy to use. Just remember the basic formula $E = IR$ and the other two forms ($I = E / R$ and $R = E / I$) are simple rearrangements of the basic formula. There is, however, one very important rule in the use of any of the three forms of the formula. This is that values entered in the formula must be in the similar units. An example will show how mixing units can cause a wrong answer. Assume that the applied voltage to a circuit is 2.0 volts and the current measured in the circuit is 1.0 milliamp. To calculate the circuit resistance, we use the formula, $R = E / I$. Do not do it by setting up the calculation as:

$$\text{Resistance} = \frac{2 \text{ Volts}}{1 \text{ milliamp}} = 2 \text{ Ohms}$$

THIS IS WRONG!!

What must be done is to convert the 1.0 milliamp to amps ($1.0 \text{ MA} = 0.001 \text{ Amp}$). Then the calculation becomes:

$$\text{Resistance} = \frac{2 \text{ Volts}}{0.001 \text{ Amp}} = 2000 \text{ Ohms}$$

The other approach would be to convert the voltage to millivolts. In this case, 2.0 volts = 2000 millivolts. The calculation then is:

$$\text{Resistance} = \frac{2000 \text{ millivolts}}{1 \text{ milliamp}} = 2000 \text{ Ohms}$$

Failure to observe the similar units rule can result in very serious errors in the design of corrosion control circuits. In the use of the basic form of the formula, $E = IR$, it should be noted that if I is expressed as amps and R is expressed as ohms, the result will be in volts. But if the current (I) is expressed as milliamps and the resistance (R) is expressed

as milliohms, the result will be in microvolts which may be misleading. It is much better to convert the I to amps and the R to ohms and get the result in volts.

THE BASIC ELECTRICAL CIRCUIT

Figure 1-3 represents a simple, or basic, electric circuit which will be used to illustrate further applications of Ohm's Law discussed in the preceding section. This will serve to solidify an understanding of the principles of the usage of the law

The Figure 1-3 representation shows all of the circuit resistance confined to a simple resistor. Now assume that a DC power source providing current to a cathodic protection system for corrosion control has instruments indicating that the supply voltage (E) is 20 volts and the current flow (I) is 5 amps, the total circuit resistance (R) can be calculated by that form of Ohm's Law, $R = E/I$. Using the values given,

$$\text{Circuit Resistance} = \frac{20\text{V}}{5\text{ A}} = 4\text{ Ohms}$$

In such a simple circuit, the entire voltage drop from the voltage source appears across the circuit resistance. To check this in the above example, Ohm's Law can be used in its basic form, $E = IR$. The current is known to be 5 amps. The resistance was calculated as 4 ohms. Then:

$$\begin{aligned} \text{Voltage drop across resistance (E)} &= \\ 5\text{A} \times 4\text{ ohms} &= 20\text{ volts} \end{aligned}$$

In another application of Ohm's Law to this basic circuit, if a 20-volt DC power source were connected across a known resistance of 4 ohms, the current flow (in the absence of an ammeter) can be calculated by that form of Ohm's Law, $I = E / R$. Then:

$$\text{Current flow (I)} = \frac{20\text{V}}{4\text{ ohms}} = 5\text{ amps}$$

From the above, it becomes apparent that in the basic electrical circuit, all of the current flows without change throughout the circuit and that all of the electrical voltage applied to the circuit appears as a voltage drop across the circuit resistance.

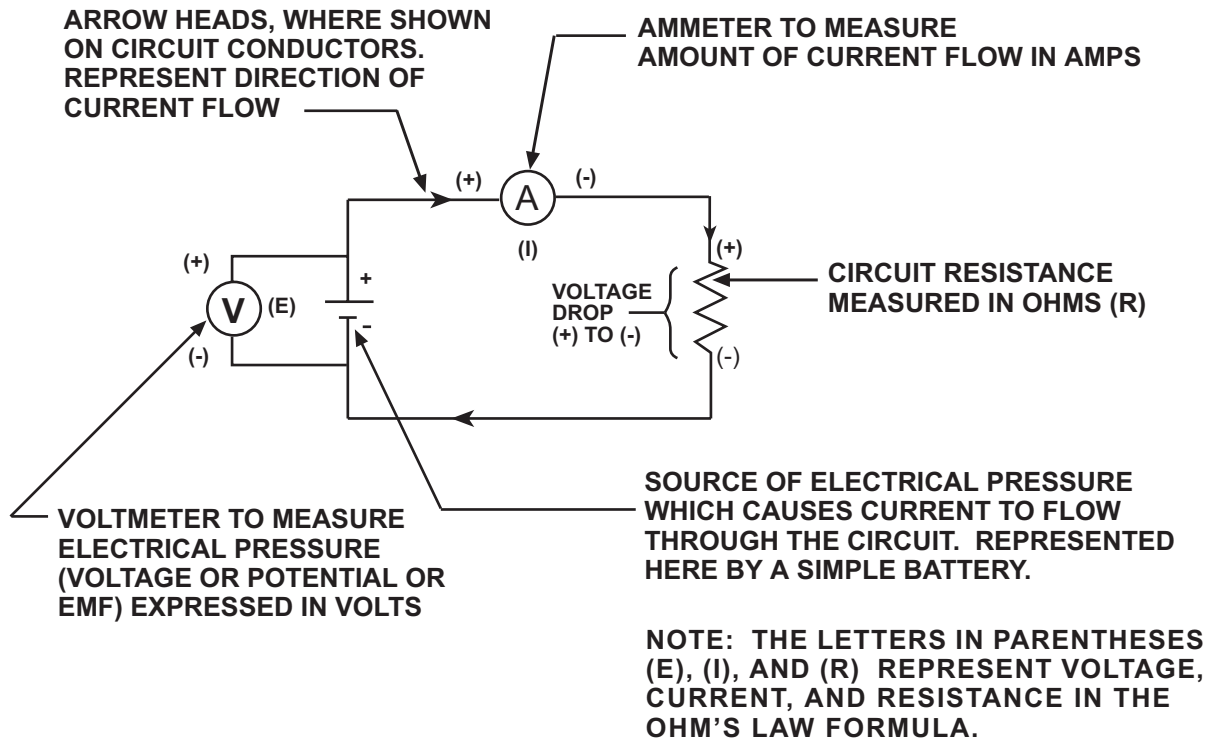

**THE BASIC ELECTRICAL CIRCUIT
FIGURE 1-3**

THE SERIES ELECTRICAL CIRCUIT

Not all electrical circuits conform to the basic electrical circuit configuration described in the preceding section.

Figure 1-4 represents an electrical circuit where the total circuit resistance comprises two or more load resistances which are connected in series. By "series", it is meant that the several load resistances are connected end-to-end and that the entire circuit current has to pass through each of the resistances. This in turn means that the voltage of the DC potential source applied to the circuit will be distributed across the several resistances in the circuit.

To illustrate the effect, assume that the following values are known with respect to the circuit of Figure 1-4:

Power supply voltage (E_s) = 10 volts

Circuit current flow (I) = 2.0 amps

Load resistance No. 1 (R_1) = 3.0 ohms

Load resistance No. 2 (R_2) = 1.87 ohms

Load resistance No. 3 (R_3)

(20 ft of No. 8 wire) = 0.13 ohms

Calculate the voltage drops across the three resistances by the $E = IR$ form of Ohm's Law.

Voltage Drop across R_1 : $V_1 = 2A \times 3 \text{ ohms} = 6 \text{ volts}$

Voltage Drop across R_2 : $V_2 = 2A \times 1.87 \text{ ohms} = 3.74 \text{ volts}$

Voltage Drop across R_3 : $V_3 = 2A \times 0.13 \text{ ohm} = 0.26 \text{ volt}$

The sum of these voltages is:

$$6 + 3.74 + 0.26 = 10 \text{ volts}$$

This matches the power supply voltage as it should. Note that the voltage drops across the resistances are proportional to the ohmic values of the resistances - - the higher the value of the resistance, the greater the voltage drop across it for a given value of current flow.

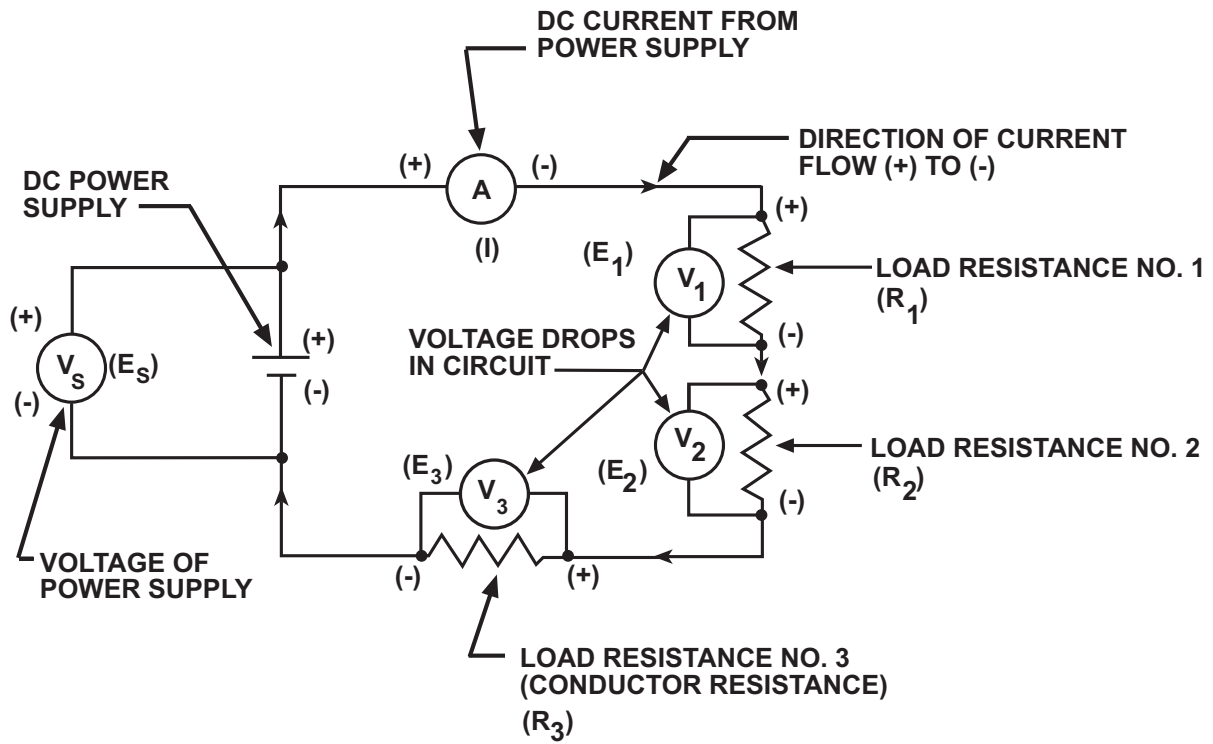

SERIES ELECTRICAL CIRCUIT

FIGURE 1-4

The sum of the resistance in the example used is:

$$3.0 + 1.87 + 0.13 = 5 \text{ ohms}$$

This should match the value of total circuit resistance calculated from the known power source voltage and current, $E_s = 10$ volts and $I = 2$ amps. To check, use the $R = E / I$ form of Ohm's Law.

Total Circuit resistance ($R_1 + R_2 + R_3$) =

$$\frac{10V}{2 \text{ amps}} = 5 \text{ ohms}$$

For another application of the Figure 1-4 circuit, assume that we do not know the ohmic values of the resistances R_1 , R_2 and R_3 . All we know is the power source voltage ($E_s = 10$ volts) and power current ($I = 2$ amps). The problem is now to determine the amount of each resistance in ohms. It soon becomes apparent that not enough information is known to determine these values without taking an intermediate step.

The necessary intermediate step is to measure the voltage drop across resistances R_1 and R_2 using a suitable DC voltmeter. The reason for neglecting the drop across R_3 will become apparent shortly.

Assume that the intermediate step has been taken with the following values recorded.

Drop across resistance No. 1 = 6 volts

Drop across resistance No. 2 = 3.74 volts

This gives all the needed information. Using the $R = E / I$ form of Ohm's Law,

$$\text{Resistance No. 1} = \frac{6 \text{ Volts}}{2 \text{ Amps}} = 3 \text{ ohms}$$

$$\text{Resistance No. 2} = \frac{3.74 \text{ Volts}}{2 \text{ Amps}} = 1.87 \text{ ohms}$$

We know from the power source voltage (10V) and current (2A) that by Ohm's Law,

$$\text{Total Circuit Resistance} = \frac{10 \text{ Volts}}{2 \text{ Amps}} = 5 \text{ ohms}$$

Therefore, the value of Resistance No. 3 has to be 5 ohms minus the sum of Resistances R_1 and R_2 :

$$\text{Resistance No. 3} = 5 - (3 + 1.87) = 0.13 \text{ ohms}$$

Note that the values of resistance so obtained agree with the values used earlier in the example - as they should.

Remember the following things with respect to a series circuit:

1. The total current from the power source flows through each resistance element in the circuit.
2. The sum of the voltage drops across the several resistance elements in the circuit must equal the voltage of the power source.
3. The sum of the ohmic values of the several resistance elements in the circuit must equal the total circuit resistance: $R_T = R_1 + R_2 + \dots + R_N$

THE PARALLEL ELECTRICAL CIRCUIT

Equally as important as the series circuit is the parallel circuit. In such a circuit, two or more load resistances are so connected that the plus (current input) ends of all resistances are connected together and the minus (current output) ends are connected together instead of being connected end to end as is the case with a series circuit. This is illustrated by Figure 1-5.

As can be seen by examining Figure 1-5, the power source voltage will be impressed on each resistance element rather than being distributed as is the case with a series circuit. Further, the power source current will be divided among the several resistance branches.

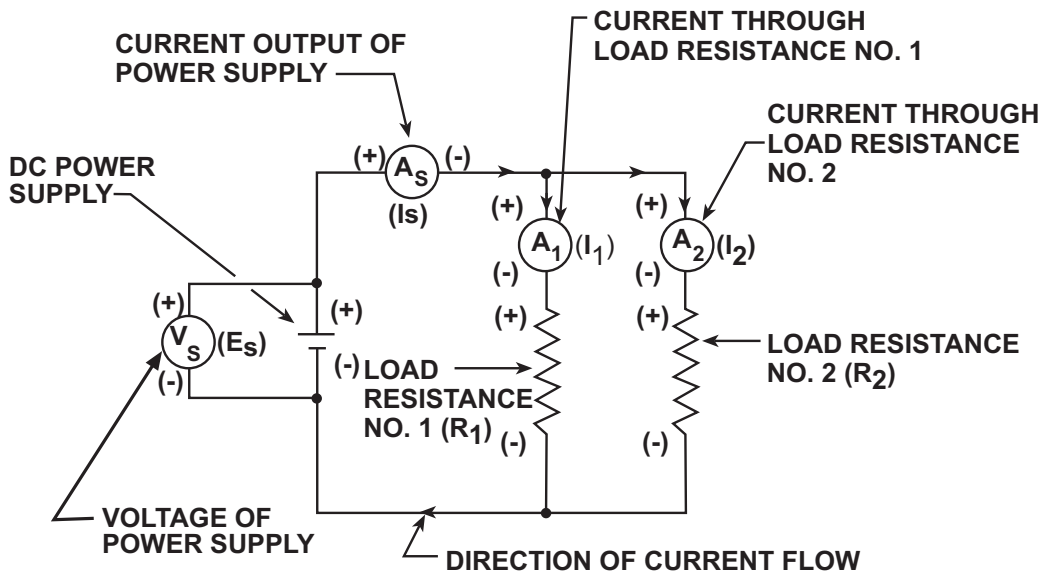

**PARALLEL ELECTRICAL CIRCUIT
FIGURE 1-5**

An example of how the parallel circuit works can be developed by assuming that the following values are known with respect to Figure 1-5:

Power supply voltage (E_s) = 20 volts

Power supply current (I_s) = 16.67 amps

Load resistance No. 1 (R_1) = 3 ohms

Load resistance No. 2 (R_2) = 2 ohms

First calculate the current flow (I_1 and I_2) through each load resistance branch. The voltage drop across each branch equals the power supply voltage (E_s) or 20 volts. Then by Ohm's Law, $I = E / R$:

Current flow through R_1 :

$$I_1 = \frac{20 \text{ Volts}}{3 \text{ Ohms}} = 6.67 \text{ amps}$$

Current flow through R_2 :

$$I_2 = \frac{20 \text{ Volts}}{2 \text{ Ohms}} = 10 \text{ amps}$$

The sum of these 2 currents should equal the power source output current of 16.67 amps - - which it does.

Second, calculate the parallel resistance of R_1 and R_2 . This is done by using the formula:

$$\text{Parallel Resistance} = \frac{R_1 \times R_2}{R_1 + R_2}$$

In this case,

$$\text{Parallel Resistance} = \frac{3\text{ohms} \times 2\text{ohms}}{3\text{ohms} + 2\text{ohms}} =$$

$$\frac{6}{5} = 1.2 \text{ ohms}$$

Note that the parallel resistance of any two resistors is always less than the smaller resistance value.

The parallel resistance of load resistances R_1 and R_2 must equal the effective total circuit resistance. This can be checked using the power supply voltage ($E_s = 20$ volts) and the total power supply current output ($I_s = 16.67$ amps). By Ohm's Law, $R = E / I$. In this case,

Effective total circuit resistance =

$$\frac{20 \text{ Volts}}{16.67 \text{ Amps}} = 1.2 \text{ ohms}$$

This checks the calculated parallel resistance of the two load resistances.

Should there be three or more parallel branches, the parallel resistance can be calculated as follows:

1. Calculate the parallel resistance of R_1 and R_2 to obtain R_{1-2} :

$$\frac{R_1 \times R_2}{R_1 + R_2} = R_{1-2}$$

2. Calculate the parallel resistance of R_{1-2} and R_3 to obtain R_{1-2-3} :

$$\frac{R_{1-2} \times R_3}{R_{1-2} + R_3} = R_{1-2-3}$$

3. Continue the same procedure for any additional branches until all branches have been included in the calculations.

Note that the resulting resistance will always be less than the smallest branch resistance in the circuit.

There is another way to calculate parallel resistances but the above procedure illustrates the principal and becomes cumbersome only if there are a large number of parallel branches. For reference, the relationship to use by the alternate calculation method is:

Parallel resistance (R_p) =

$$\frac{1}{\frac{1}{R_1} + \frac{1}{R_2} + \frac{1}{R_3} + \frac{1}{R_4} + \dots + \frac{1}{R_N}}$$

Or:

$$\frac{1}{R_P} = \frac{1}{R_1} + \frac{1}{R_2} + \frac{1}{R_3} + \frac{1}{R_4} + \dots + \frac{1}{R_N}$$

Remember the following important points with respect to a parallel circuit:

1. The full power supply voltage is impressed across each parallel branch.
2. The sum of the currents through the individual parallel branches must equal the total current output of the power source.
3. The parallel resistance of two or more branches will always be less than that of the smallest branch resistance.

COMBINATION CIRCUITS

Electrical circuits can be a combination of series elements and parallel elements. A simple case is illustrated by Figure 1-6.

Calculation procedures applicable to such a combination circuit are in general accord with the principals covered in the sections on series circuits and parallel circuits. There are, however, certain important differences to be noted.

The power supply output current divides between the two parallel branches R_1 and R_2 and then combines again after passing through these resistances. The full power supply current then passes through the resistance element R_3 .

The voltage drop across parallel branches R_1 and R_2 will be equal to each other.

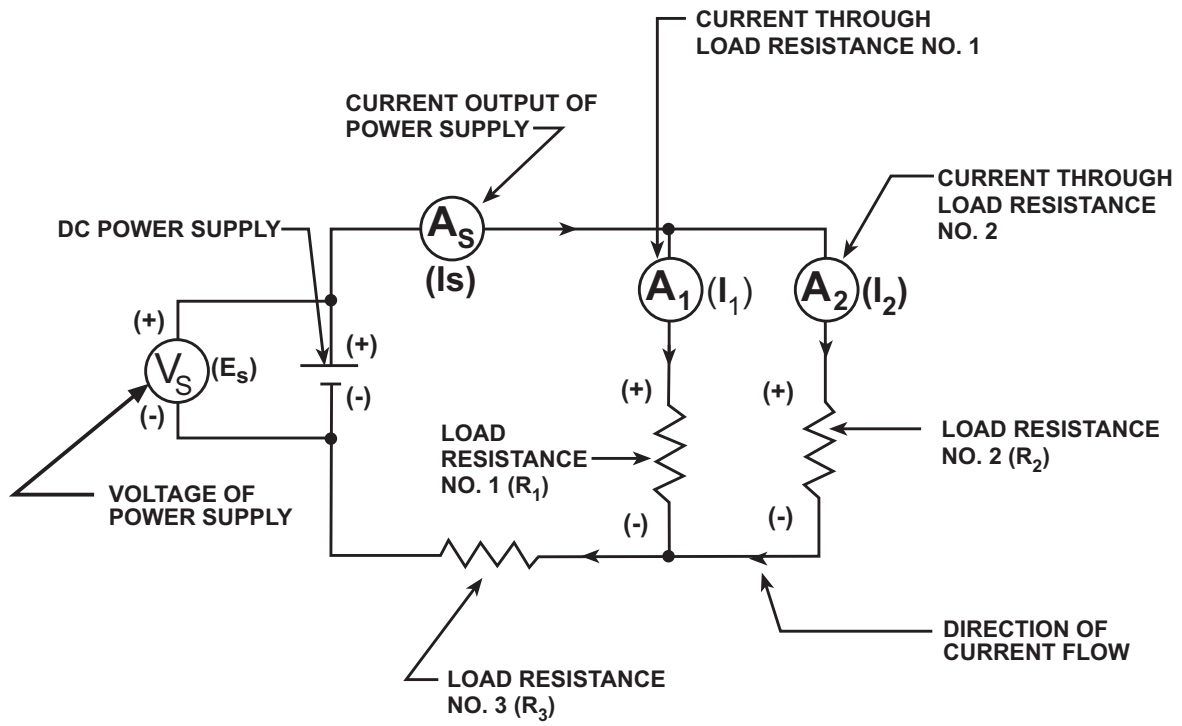

COMBINATION ELECTRICAL CIRCUIT

FIGURE 1-6

However, the amount of the voltage drop will be the power supply voltages less the voltage drop across series resistance R_3 .

The effective circuit resistance will be the calculated parallel resistance of branches R_1 and R_2 plus the resistance of series resistance R_3 .

Chapter 2 - Corrosion Fundamentals

INTRODUCTION

Corrosion is a major problem associated with underground structures. Modern industrial plants, universities, hospitals, cities and utility companies utilize many underground systems and corrosion failures become expensive, cause shutdowns, hazardous conditions, occasional fires or other catastrophes, and cause inconvenience to both personnel and the public.

Corrosion is an electrochemical reaction between a metal and its environment. Essentially, it is the tendency of a refined metal to return to its natural state as an ore. Corrosion always involves a flow of direct current electricity through an electrolyte such as soil or water from one point to another on a metal surface. This current is generated by a potential or voltage difference between the two points.

There are many forms of corrosion. Metallic materials can be affected by corrosion to varying degrees depending on factors such as, alloy composition, fabrication, heat treatment, exposure environment, electrical contact with dissimilar metals, stray currents and so forth. Strictly speaking, the term galvanic corrosion refers to accelerated corrosion of a metal because of electrical contact with a more noble metal or conductive nonmetal in a corrosive electrolyte. However, this term is sometimes also used to describe corrosion due to potential differences created by various factors on the same metal, such as flaws or scratches in conductive surface films that expose the base metal, variations in concentrations of salts and dissolved gases in the environment contacting the metal surface, highly stressed versus less-stressed areas, etc. The term natural corrosion (or self-corrosion) is preferred when corrosion occurs on a single metal in the absence of electrical contact with a dissimilar metal or conductive nonmetal and in the absence of stray currents. Natural corrosion can manifest itself in various forms such as general or uniform attack, pitting, crevice corrosion, etc. All forms of aqueous corrosion involve some type of electrochemical corrosion cell. In soils, moisture is essential for corrosion attack, which can be aggravated by increasing acidity, oxygen content, concentration of dissolved salts, bacteria, cinders, etc.

This chapter describes the fundamental corrosion cell and its relation to underground structures. Various types of natural cells are discussed and examples are given. Some other types of corrosion, basically variations of galvanic cells, are shown also to give a general picture of this aspect of "what makes the structure fail". The chapter then goes on to describe stray current corrosion and gives examples of both dynamic and static

stray current situations. Finally, factors affecting the rate of corrosion are explained.

FUNDAMENTAL CORROSION CELL

Corrosion is, in effect, similar to a dry cell. In order for corrosion to occur, we must have four elements, namely: Electrolyte, anode, cathode and a return circuit. Refer to Figure 2-1. Note that it is basically a dry cell. The electrolyte is a substance such as earth or water capable of carrying an electric current. For simplicity's sake, we say it consists of hydrogen (H^+) and hydroxyl (OH^-) ions, positively and negatively charged elements of water. What occurs is basically this. At the anode, metal particles (positively charged ions) dissolve into the electrolyte. This leaves electrons behind on the surface of the anode. The electrons flow to the cathode through the return circuit. Now the electrolyte must remain electrically neutral. Therefore, since positive ions have been added to the electrolyte at the anode, some other positive ions must be displaced. One reaction that may occur is the displacement of hydrogen. Hydrogen ions accept the electrons at the cathode and become hydrogen gas. This evolution of hydrogen is a type of polarization. When the film of hydrogen remains on the cathode surface, it acts as an insulator and reduces the corrosion current flow.

Another reaction also occurs. In the case of steel, ferric (iron) ions flow into the electrolyte at the anode. These ions react with the hydroxyl ions to form rust. If the rust adheres to the metal surface, it may coat the surface and also slow down the flow of corrosion current. This is a type of anodic polarization. Polarization is discussed later in the chapter.

Here are reactions that can occur:

At the anode:



At the cathode:

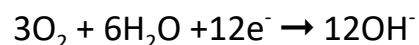
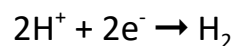

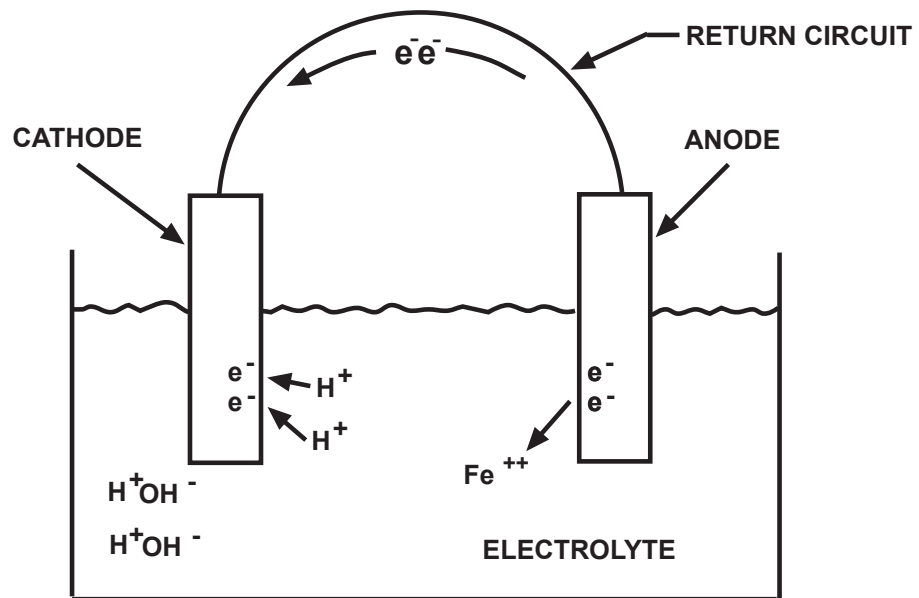

FUNDAMENTAL CORROSION CELL

FIGURE 2-1

The influence of oxygen on corrosion is easily seen. The reaction produces additional hydroxyl (OH⁻) ions to react with the ferric (Fe³⁺) ions, thus increasing the propensity for ferric ion production (corrosion).

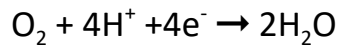

This reaction and the preceding one consume electrons at the cathode. The greater the propensity to consume electrons at the cathode, the greater the tendency for the production of metallic ions at the anode (dissolution of metal - corrosion).

It is important to emphasize that the corrosion reactions shown above are not plating reactions. There is no migration of ions from the anode to the cathode, that is, metal does not move from the anode to the cathode.

We have shown so far that corrosion involves the flow of both ions and electrons. This is why it is called an electrochemical process. Now let's simplify it a bit. We don't really care about the electrons since they stay in the metal and don't cause any trouble. What we care about, however, is the flow of ions (charged particles) into the electrolyte at the anode. This is what causes corrosion. As we have seen, the ions don't actually flow from the anode to the cathode in the electrolyte, but rather there is a migration of ions into the electrolyte at the anode and out of the electrolyte at the cathode. We say, however, for simplicity's sake, that there is a flow of current from the anode through the electrolyte to the cathode. Since the anode and the cathode are connected by the return circuit, we say the current flows back to the anode through this circuit. This is the so-called conventional flow - through a wire from the positive to the negative terminal of a battery.

Accepting the proposition of "conventional" current flow, the corrosion cell may be summed up as follows:

1. Current flows through the electrolyte from the anode to the cathode. It returns to the anode through the return circuit.
2. Corrosion occurs wherever current leaves the metal and enters the soil (electrolyte). The point where current leaves the metal is called the anode. Corrosion, therefore, occurs at the anode.
3. Current is picked up at the cathode. No corrosion occurs here. The cathode is protected against corrosion. (This is the basis of cathodic protection, by the way.)

Polarization (hydrogen film build-up) occurs at the cathode.

4. The flow of current is caused by a potential (voltage) difference between the anode and the cathode.

Figure 2-1 showed the fundamental cell as a battery. Figure 2-2 shows how such a cell develops on a pipeline, or similar structure. The only difference between galvanic and stray current corrosion is this: In stray current corrosion, some external source of current is inserted into the return circuit.

TYPES OF GALVANIC AND NATURAL CORROSION

Dissimilar Metals

Where dissimilar metals are in electrical contact with one another underground, there will be a potential difference between them. This will cause current to flow with the less noble of the two being the one to corrode.

There is a natural potential difference between different metals when immersed in a conducting electrolyte. This is illustrated by Table 2-1 which is a practical galvanic series indicating voltages which can be expected when measuring metal potentials with respect to a standard copper-copper sulfate reference electrode when both are in contact with neutral soils or waters. The values shown in the table serve as a general guide only since they are subject to some variation as the environment changes.

If any two materials having different voltages are connected together and placed in a conducting environment, there will be a potential between them equal to the algebraic difference of the two voltages. The material which is listed uppermost in the table will be the anode and the other (more noble) material will be the cathode. As an example, if lead (-0.5 volt) and copper (-0.2) are the pair of metals selected, the potential difference will be 0.3 volt with lead (uppermost in the table) being the corroding anode and copper the cathode.

As another example, take zinc (-1.1 volt) and carbon (+0.3 volt). The potential difference (since the carbon is plus) will be 1.4 volts and the zinc will be the corroding anode. This example is given because the 1.4 volt figure does not agree with the 1.6 volt value normally found with a new carbon-zinc dry cell battery. This simply illustrates that the material potentials are subject to variation with electrolyte composition; the dry cell electrolyte has been selected to give maximum practical output voltage.

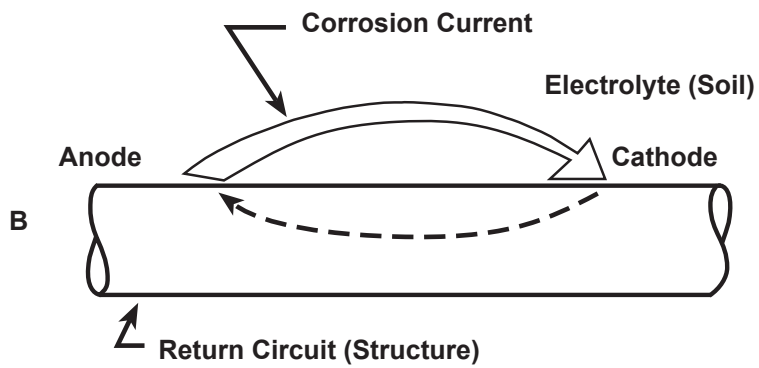
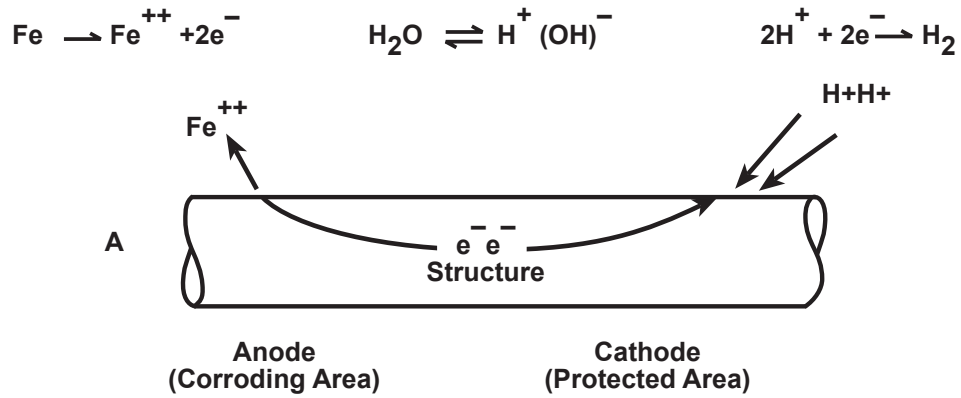

**FUNDAMENTAL CORROSION CELL
 AS IT APPLIES TO A PIPELINE
 A Electrochemical cell
 B Conventional current cell**

FIGURE 2-2

If underground structures happen to be buried in earth containing cinders where the cinders are allowed to be in direct contact with the structure metal, there will be a very strong galvanic cell causing corrosion of the structure metal. This is because cinders are essentially carbon. Inspection of the figures in Table 2-1 will show that the potential between, for example, new steel and carbon can range between 0.8 volt and 1.1 volt. These are seriously high galvanic cell potentials. The effect is illustrated by Figure 2-3. The corrosion caused by cinders can be very difficult to control on existing structures. It should be emphasized that contacts with cinders should always be avoided on new construction.

Figure 2-4 illustrates steel and copper pipe being electrically joined together. The galvanic series of Table 1 indicates that the steel will be less noble and will be the corroding anode. The copper will be the cathode and not corroding. It should be noted that this is why copper often has been considered to be a corrosion free material when used underground. This is because of widespread use of copper service pipes on steel or cast iron systems such that the copper is made a cathode (free of corrosion) by virtue of being in contact with the steel or cast iron. This relative corrosion freedom is gained at the expense of the steel or cast iron.

Dissimilar Surfaces

Another not-so-obvious example of dissimilar metal corrosion is the insertion of a piece of new steel pipe welded into an old underground rusty steel pipe. Again, Table 2-1 indicates that there will be a potential difference between the two and it will be the new steel pipe that corrodes. Typically, such a piece of new pipe used to replace a section that has failed from corrosion will not (in the absence of some means of corrosion control) last as long as the original piece because of this new steel-old steel relationship. See Figure 2-5.

Another related example is dissimilarities in surface conditions on a pipe. In threaded underground pipe assemblies, if a pipe wrench is used on piping, the teeth of the pipe jaws can bite into the surface of the pipe exposing bright metal. After rebackfilling, these pipe wrench scars will be anodic to adjacent cathodic pipe metal and will corrode in the absence of adequate corrosion control. Also, when threads are cut into the pipe, the bright metal exposed by the thread cutting will likewise be anodic where exposed to earth and will corrode in the absence of suitable corrosion control. These reactions are shown in Figure 2-6.

Similarly, on existing underground pipe systems, if a sharp pointed probe rod is used to

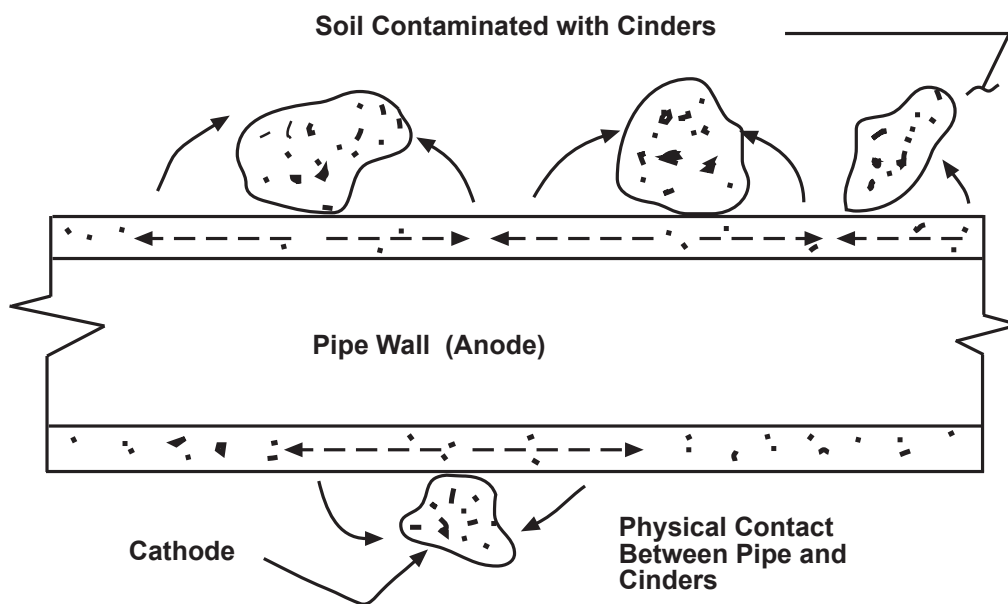

CORROSION DUE TO CINDERS

FIGURE 2-3

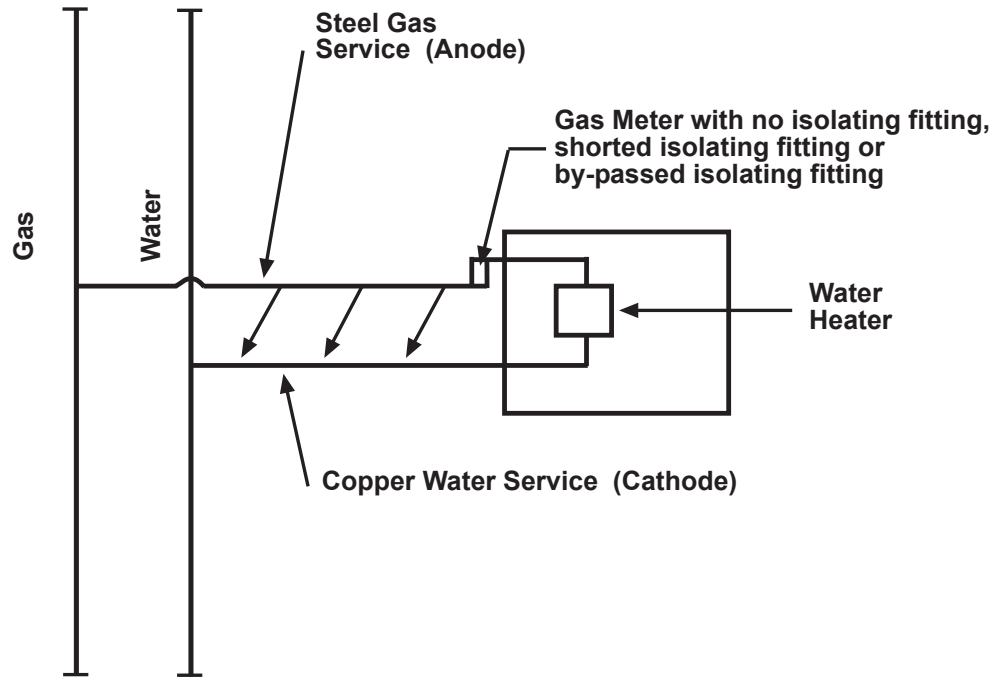

**DISSIMILAR METAL CORROSION
GAS AND WATER SERVICE LINES**

FIGURE 2-4

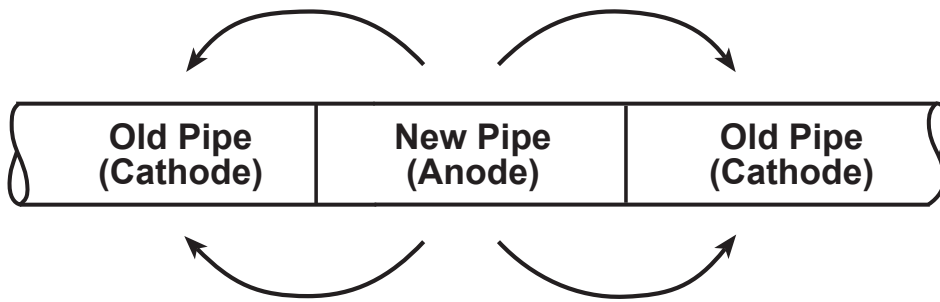

NEW-OLD PIPE CELL

FIGURE 2-5

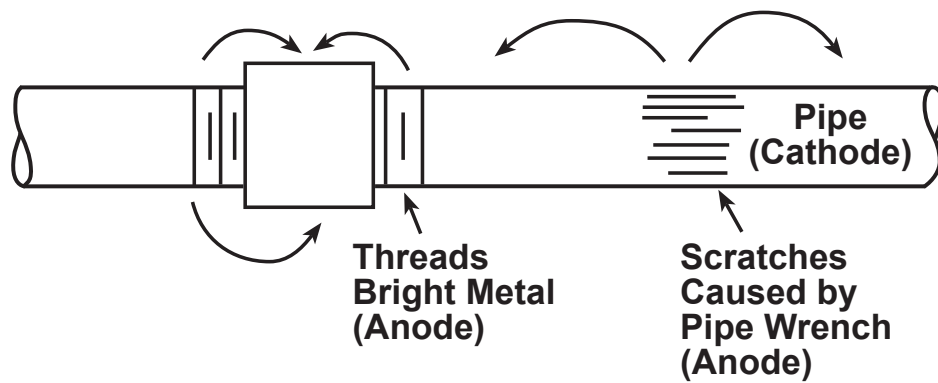

**CORROSION CAUSED BY
DISSIMILARITY OF SURFACE CONDITIONS**

FIGURE 2-6

make electrical contact with the pipe during corrosion control test work, the bright metal scars left by the probe rod will be anodic to adjacent pipe. Unless there is a suitable corrosion control system in operation, dissimilar metal corrosion cells can develop at these scars.

Mill scale, although not a metal, is electrically conductive and has a characteristic potential which is more noble than that of the underlying steel. Inspection of Table 2-1 indicates that the potential between mill scale and new steel can be in the range of 0.2 volt to 0.5 volt - with steel being the corroding material. In the absence of effective corrosion control, corrosion of the steel can be rapid since, typically, the current discharge is concentrated in a small area.

Mill scale is a thin and usually tightly adherent surface oxide film on hot rolled steel as it comes from the steel mill. Where buried structures are built using steel from which such scale has not been removed, corrosion cells can occur at breaks in the mill scale such that the underlying steel is exposed to contact with the environment. This is illustrated by Figure 2-7.

Dissimilar Soils

Just as dissimilar metals are the source of electrical potential in corrosion cells, dissimilar soils can also be a source of voltage difference. It is rare indeed to have a completely uniform soil in which an underground structure is buried. In the more usual case, there will be changes in characteristics of the soil from point-to-point along a buried structure. This is illustrated in principle by Figure 2-8. The figure shows two different soils, Soil "A" and Soil "B". It also shows that if the potential of the steel pipe in soil "A" is measured with a voltmeter with respect to a standard reference electrode (such as copper-copper sulfate electrode), it will have a different potential from that similarly measured in soil "B". In the case shown, the difference between the two readings is $0.5 - 0.3 = 0.2$ volt with soil "A" being positive (+) to Soil "B". With a current flow path being established between the two soils by the buried steel pipe, the current flow path will then be, (1), from the more positive soil "A" to soil "B", (2), from soil "B" onto the steel pipe in soil "B" - thus making it cathodic and non-corroding, (3) along the pipe itself from the soil "B" area to the soil "A" area, and finally (4) discharging from the pipe in soil "A" to complete the circuit. This makes the pipe in soil "A" anodic and corroding.

Conditions are seldom as clearly defined as shown in Figure 2-8. By the time excavations are made for a buried structure and the structure is finally backfilled, there may be a mixture of soil types in the backfill. This tends to give a condition illustrated by Figure

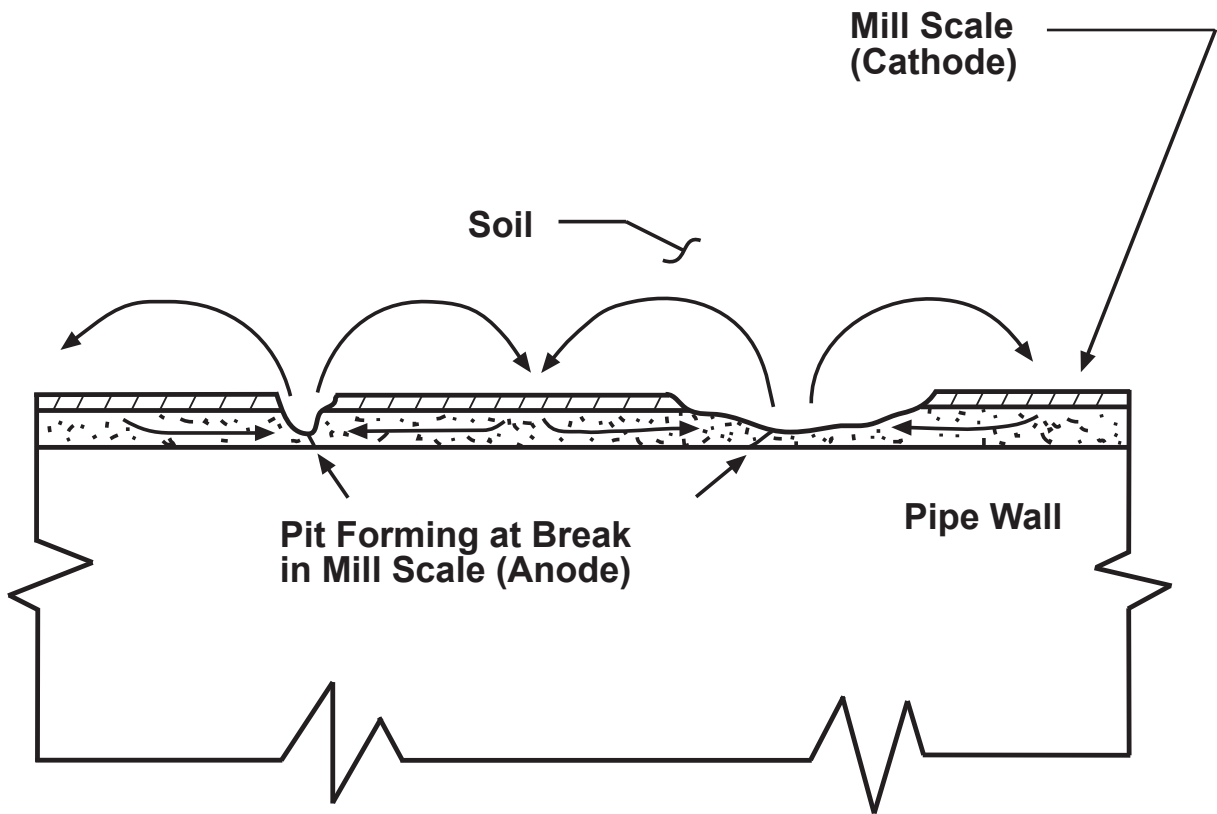

PITTING DUE TO MILL SCALE

FIGURE 2-7

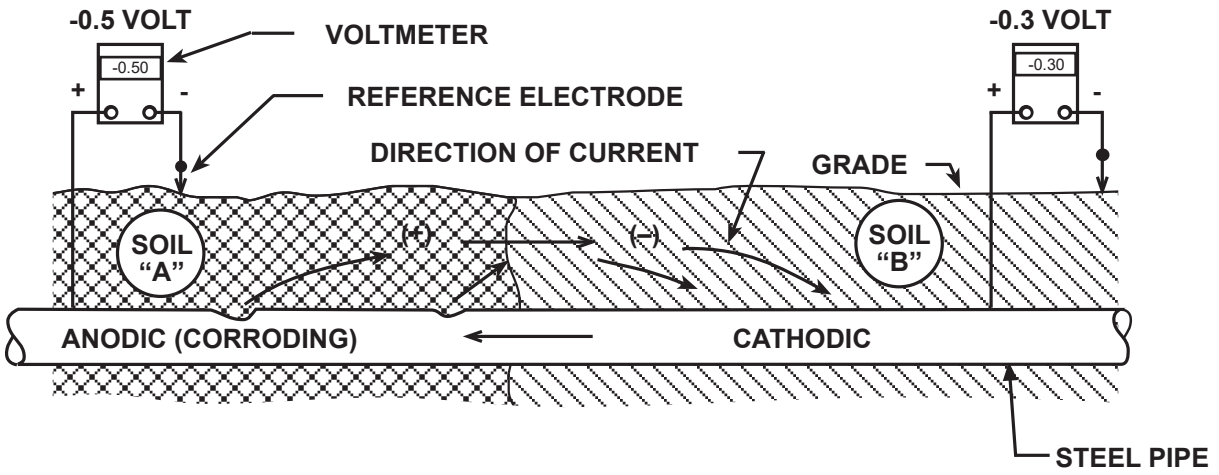

**DISSIMILAR SOILS AS SOURCE
OF CORROSION CELL POTENTIAL**

FIGURE 2-8

2-9 which leads to numerous anode-cathode relationships along the structure. The effects of this condition can be seen when an old steel underground structure (such as a pipeline which has never had corrosion control measures applied) is uncovered for inspection. Typically, there will be heavily corroded areas (anodic) next to areas (cathodic) which can be in nearly as new condition.

Differential Aeration

Another source of electrical potential causing corrosion current to flow is differential aeration. This simply means that when oxygen from the air (aeration) is more readily available through the electrolyte to one part of a structure than to another, there will be a difference in potential between the two. When this condition exists, that part of the structure having restricted oxygen availability will be anodic and will corrode.

A typical example on a buried pipe is illustrated by Figure 2-10 which demonstrates the effect of restricted oxygen availability to the pipe under a paved road while there is good oxygen availability through porous earth to the pipe on either side. This would be the case even though the soil is otherwise uniform through the area. As was illustrated on Figure 2-8, it would be found that the pipe under the paving is more negative with respect to earth than is the pipe in well aerated soil on either side of the road. This is indicative of an anodic area under the road and results in current flow in the directions indicated by Figure 2-10.

Another example, again using pipe to illustrate the point, can occur if a buried pipeline is bedded in dense soil at the bottom of the pipeline trench, while relatively loose backfill permits greater oxygen availability to the top of the pipe than to the bottom. In such a situation, corrosion cell current flow can be from the bottom of the pipe to the top. If this is the major factor causing corrosion, failures will be on the underside of the pipe - which usually makes pipe repair more difficult. See Figure 2-11.

Stress Corrosion

Where there is an area of differential stress on any part of an underground structure, that part which is more highly stressed will be anodic (and corroding) with respect to adjacent, less highly stressed parts of the structure. The effect is illustrated by Figure 2-12 which could represent an underground bolt or tie rod having a reduced cross-section at one point. In this reduced cross-sectional area, the actual metal stress in terms of pounds per square inch of cross-section is higher than in the remainder of the bolt or tie rod.

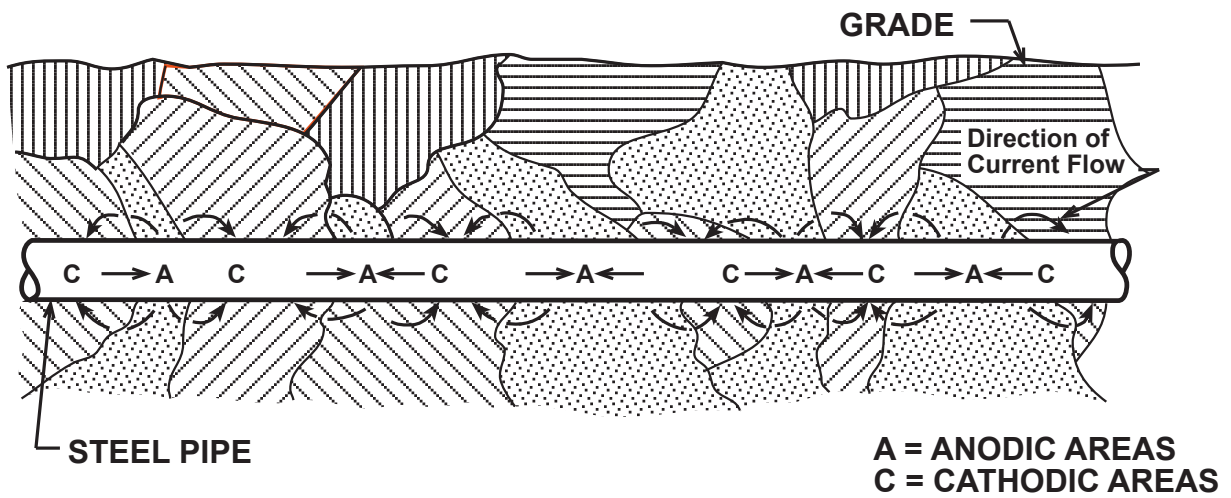

**MIXTURE OF DISSIMILAR SOILS
AS SOURCE OF CORROSION CELL POTENTIALS**

FIGURE 2-9

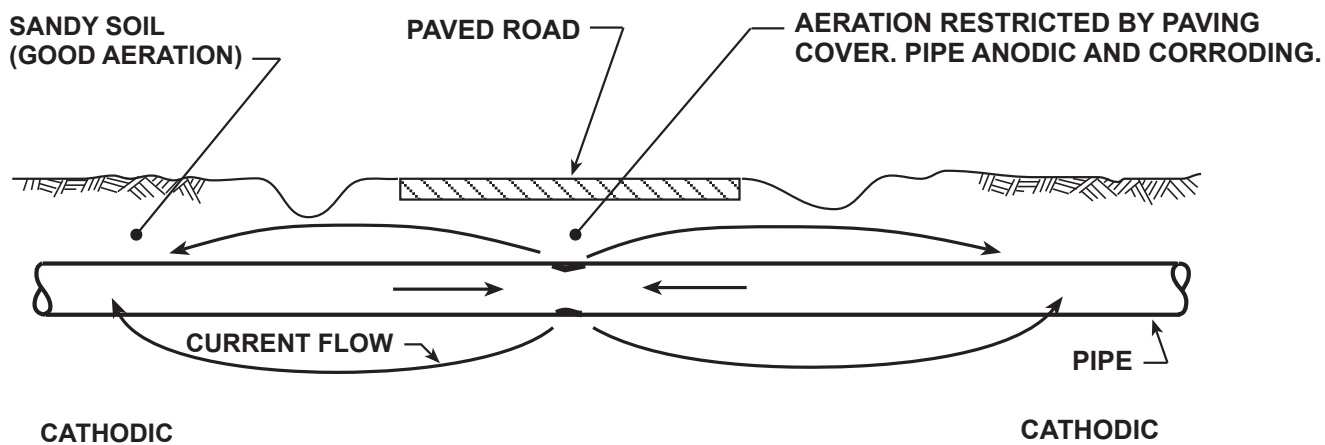

**DIFFERENTIAL AERATION AS A
SOURCE OF CORROSION CELL POTENTIAL**

FIGURE 2-10

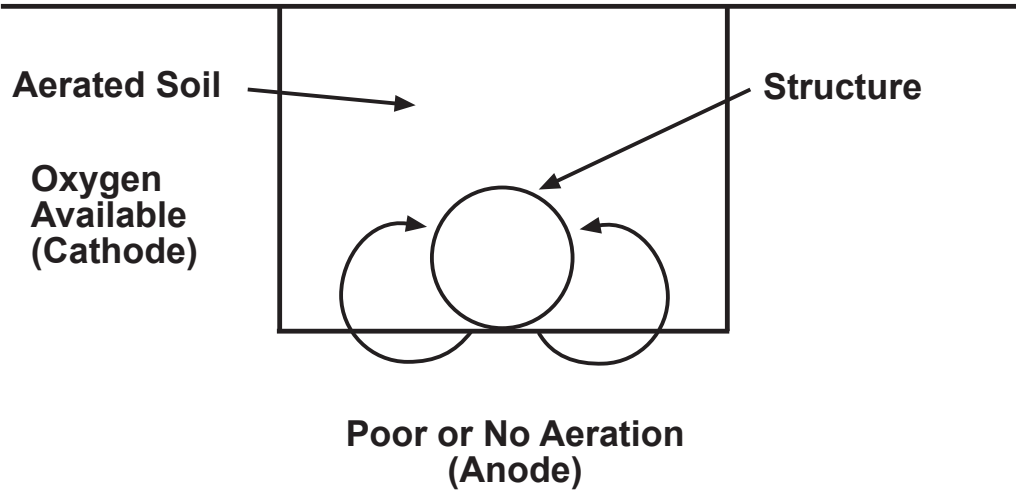

**CORROSION CAUSED BY
DIFFERENTIAL AERATION OF SOIL**

FIGURE 2-11

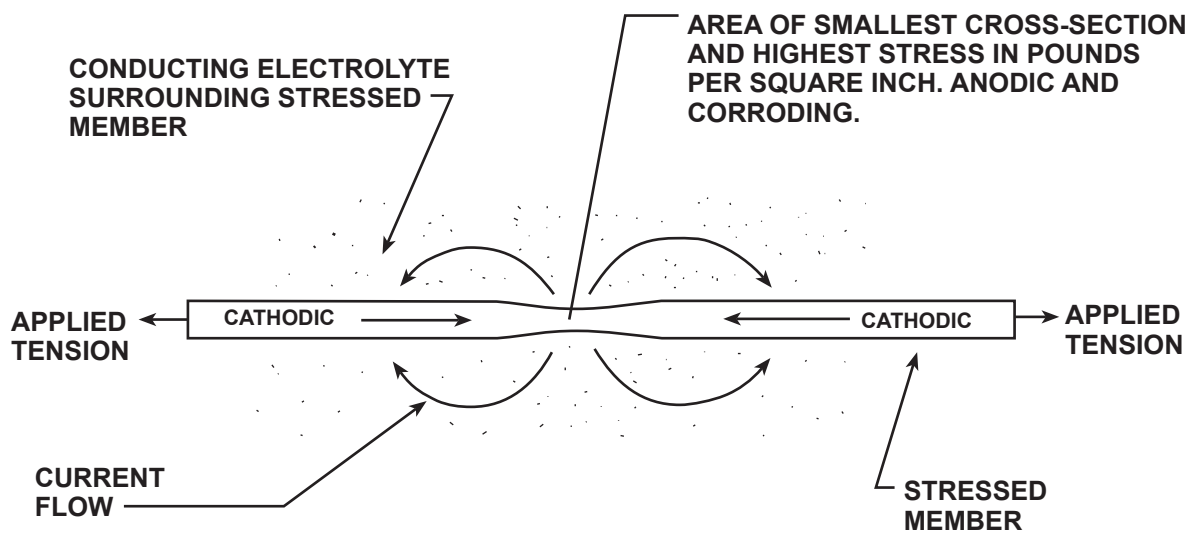

**DIFFERENTIAL STRESS AS A SOURCE
OF CORROSION CELL POTENTIAL**

FIGURE 2-12

A reduced cross-section may not be present in the member when installed. However, another source of corrosion such as dissimilar soils or differential aeration (discussed earlier) may initiate corrosion attack which will cause a localized reduction in cross-section. This then permits the establishment of the differential stress corrosion cell which can then act in addition to the original corrosion cell - thus aggravating the attack.

Very often, the bolts of a coupling will be found to be necked down or even broken in the middle. The center of the bolt is more highly stressed than other parts because of stress concentration at this location. The flow of current is shown on Figure 2-13.

Where high strength alloy steels are used in underground structures which are highly stressed (such as high pressure pipelines), a phenomenon known as stress corrosion cracking may be encountered. In such situations, another source of corrosion can initiate a corrosion pit which will act as a local stress raiser in the structure metal.

The resulting differential stress corrosion cell can then act in conjunction with the original corrosion cell as above except that cracks may develop in the structure metal at the base of the initiating pits with, in many cases, catastrophic failures occurring. Sometimes the cracks are known as "transgranular" where the crack passes through metal grains or crystals. In other cases, the cracks can be "intergranular" where they follow a zig-zag path along the boundaries of the metal grains or crystals.

The study of stress corrosion cracking has been the subject of intense research as the phenomenon is subject to many variables such as stress level, the metal alloy, nature of the environment, temperature, metal contaminants, etc., etc. An alloy which is resistant to stress corrosion cracking under a given set of conditions may behave quite differently under other conditions.

Cast Iron Graphitization

Where cast iron is used in underground construction and corrodes, the physical appearance of the corrosion can be quite different from the usual pitting on steel pipe. This is because cast iron contains in the order of 3% to 4% carbon (in contrast with steel which has typically only a fraction of 1%). When gray cast iron is poured in the molten condition, the cooling action converts much of the carbon to graphite - another form of carbon. The graphite is present in the form of particules or flakes in the cast material. In a corrosive environment the iron corrodes, leaving behind the graphite and products of corrosion. This leaves a mechanically weak material which retains the original shape of the structure without pitting as is the case with steel. This form of cast iron corrosion

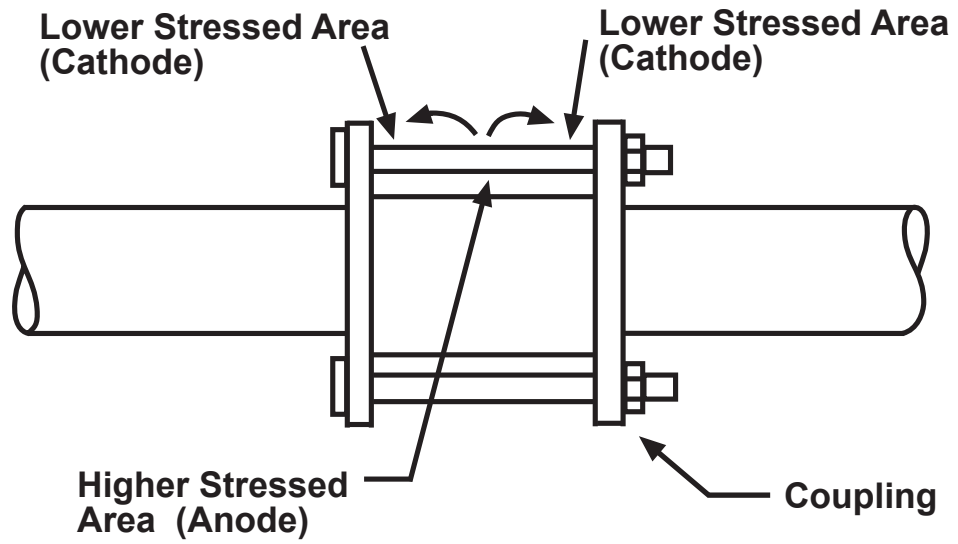

STRESS CORROSION

FIGURE 2-13

is commonly known as "graphitization". The graphite material on thus-corroded cast iron can be easily cut or scraped away with a knife.

The condition can be accelerated by stray current attack.

Where cast iron is used in water mains, for example, the pipe may become heavily graphitized in severely corrosive areas and still continue to carry water through the earth-supported graphitic structure. Eventually the pipe becomes so weak that a pressure surge or heavy traffic vibration will cause the pipe to rupture causing a major leak. Such a rupture may be the first indication that a severe corrosion problem exists the area.

Graphitization occurs to some extent on ductile iron, but not so aggressively as on cast iron. Ductile iron tends to pit like steel.

Microbiologically Influenced Corrosion

Colonies of certain types of bacteria can establish conditions on the surface of underground structures which cause more rapid corrosion by existing cells. One of the more significant types of bacteria which can involve a corrosion problem is the "anaerobic" type - which simply means that the bacteria thrive in the absence of oxygen. The most common problem-causing bacterium of this type is known as *Desulfovibrio desulfuricans*, a form which reduces any sulfates present at the underground metal surface to produce hydrogen sulphide and consumes hydrogen in the process. At the metal surface, this action consumes hydrogen which forms at cathodic surfaces of existing corrosion cells. This intensifies the action of the corrosion cell by depolarization, as discussed under the heading "FACTORS AFFECTING THE RATE OF CORROSION."

From the above it is apparent that the bacteria do not themselves attack the metal - but do cause the intensification of existing corrosion cells. Anaerobic bacteria are apt to be found in heavy, dense, water logged soils where oxygen availability is at a minimum. They can exist, however, under less favorable conditions or under a covering material which locally restricts oxygen availability. A disbonded pipeline coating is an example.

Bacteria require organic material as a food supply. This is normally available to at least some degree in the earth. However, if a major food supply is combined with oxygen restriction, the action can be intensified. A simple example of this is a piece of wood lying against an underground bare metal structure.

Combinations of Corrosion Cell Effects

A corrosion problem at a given point on an underground structure is not necessarily confined to just one of the previously discussed types of corrosion cells. Two or more sources of corrosion cell current may in fact be acting at a given location - such as, for example, a dissimilar soil corrosion cell which is further aggravated by the presence of anaerobic bacteria and cinders in the backfill.

Amphoteric Metals

Certain metals when made cathodic can corrode. These are referred to as "amphoteric", meaning that they are sensitive to strongly alkaline conditions. Lead, tin, and aluminum are examples of such metals although most metals tend to be susceptible to some degree if subjected to intense alkalinity. Of the three examples given above, aluminum tends to be the most susceptible.

The term "amphoteric" means "partly one and partly the other". In this particular application, it means that amphoterically-sensitive metals can (under certain conditions) be collecting current from the environment, which is a cathodic condition and yet be corroding which is normally an anodic condition.

In a corrosion cell, the concentration of hydroxyl ions (OH-) at the cathode surface causes an increase in alkalinity at the cathode surface. This action in connection with galvanic or other corrosion cells will not normally create a corrosive condition on an amphoteric metal such as aluminum. However, where there is intense current collection on a cathodic surface under certain stray current conditions or where excessive cathodic protection current (see Chapter 3) is collected on cathodic surfaces, a particularly sensitive amphoteric metal such as aluminum can be subject to increased corrosion.

STRAY CURRENT CORROSION

Definition of Stray Current Corrosion

Stray current corrosion is that caused by earth path direct current from some source external to the underground metallic structure which can be picked up by the structure at one point (creating a cathodic condition), flow along the structure for a distance, and then discharge into the environment in order to complete the circuit to the external source. Where the discharge occurs, an anodic condition exists with, in some cases, a very severe corrosive effect on the underground structure.

Stray current problems tend to be most severe on long underground structures, such as pipelines, but can be a problem with any underground structure if stray currents are present in the earth.

Differences Between Stray Current Corrosion and Galvanic and Natural Corrosion

Whereas in galvanic and natural corrosion, corrosion cell driving potentials are small (typically less than a volt) and corrosion currents tend to likewise be small, the driving potentials from an external source causing stray current to flow can be many volts, and in severe cases, the stray current on an underground structure can be hundreds of amperes.

Severity of Stray Current Corrosion

If stray current is allowed to discharge from an underground structure into the environment without corrosion control measures, the rate of corrosion attack can be extremely rapid. Structure failure, under these conditions, can occur within a short period of time. This is entirely logical (where, for example, hundred of amperes are discharged) in accord with the electrochemical equivalent of the metal involved as will be discussed later.

Why Stray Current Occurs

Some stray current effects are result of parallel paths where the affected structure serves as a parallel path for the earth current as shown in Figure 2-14.

As can be seen from the figure, some of the current flowing through the earth to the DC source is picked up by the metallic structure (typically a good conductor) which happens to be going in the direction that the current wants to go. There are now two parallel paths - the path through the earth and the path through the structure. As the current on the structure approaches the source of stray current, however, it has to leave the structure to reenter the earth in order to complete its circuit. This is where the corrosion damage occurs.

Alternating Current

Alternating current (AC) can also cause corrosion. One example of this is AC induced on a pipeline when it parallels an overhead high voltage AC power system. If the induced AC current is discharged at coating holidays, and where the current density is high

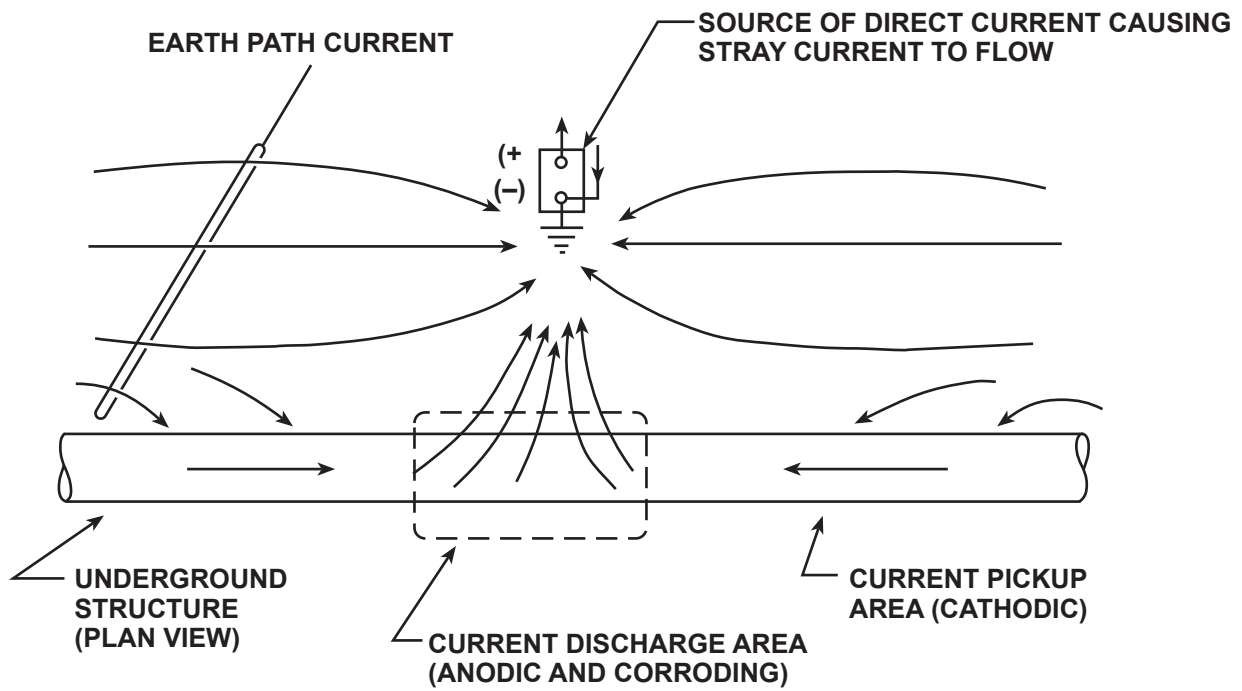

**PARALLEL EARTH PATHS
CAUSING STRAY CURRENT CORROSION**

FIGURE 2-14

enough, localized corrosion damage can be very significant. AC corrosion and mitigation is covered in the Advanced course.

AC can also be a safety hazard. AC can cause both sparks and shocks. You should be especially careful on coated pipelines that parallel high voltage overhead electrical lines. Underground tanks and piping may carry AC if buildings in the area do not have proper electrical grounding.

Types of Stray Current Corrosion

There are two types of stray current, dynamic and static.

Dynamic stray currents are those which are subject to variation with time - often to a very marked degree. Sources of dynamic stray current can cause changes in current pickup and discharge areas on a structure and can cause reversal of current flow on a structure in some instances. This all results in changes in the location of anodic and cathodic areas.

Static stray currents are those which are from a steady state external DC voltage source which causes fixed anodic and cathodic areas on affected structure with a relatively constant amount of current flow on the structure.

Sources of Stray Current Corrosion

Sources of stray current can be either man-made (usually the more serious) or natural.

Man-made sources of stray direct current include the following:

- DC powered transit systems
- DC powered mining operations
- DC welding operations
- High voltage direct current (HVDC) electric power transmission systems
- Cathodic protection systems (see Chapter 3) on underground structures other than the affected structures

A natural source of stray current is what is known as "telluric" or earth current of magnetic origin. These are direct currents, of a variable nature, in the earth's crust which are a result of variations in the earth's magnetic field. These variations in the magnetic field are in turn caused by variations in solar activity.

Telluric currents are dynamic in nature with areas of current pickup and discharge subject to constant change and with reversals in direction of current flow.

The effects of telluric current are generally more apparent on long structures such as pipelines and tend to be more significant in some areas of the world than in others. In extreme cases, short term currents may be seen which are in the hundreds of amperes - although these seldom last more than a few minutes.

Telluric currents are particularly apt to have some of the characteristics of alternating current, with attendant reduction in corrosivity. This plus the usual movement of anodic and cathodic areas from point to point distributes the damage that does occur. For these reasons, specific correction measures for telluric currents are seldom used except in extreme cases. Rather, corrective measures applied for corrosion control or for other forms of stray current are relied upon to absorb the impact of telluric currents.

Typical Stray Current Sources

Cathodic protection systems will be described in more detail in Chapter 3. For purposes of stray current effects, however, it will be sufficient to indicate that "impressed current" cathodic protection systems involve circulating direct current between a cathodically protected structure and an anode bed through which current is forced into the earth. A source of DC power is used to force this current to flow. The driving voltage of this power source can range from a few volts to (in unusual cases) over 100 volts. Also the current can range from less than 10 amps to (for large industrial installations) hundreds of amps.

In any event, this type of installation involves steady state conditions once installed and adjusted. For this reason, any stray current effects on other underground structures in the area are of the static type of effect rather than dynamic as is the case with other stray current sources that have been described.

It should be noted that there may be sources of static stray current other than cathodic protection systems. This could be the case, for example, with industrial processes. Cathodic protection installations are used for this discussion since stray current effects from them are encountered frequently in underground corrosion control work - particularly on pipelines.

Stray current effects from static sources such as cathodic protection systems are often referred to as stray current interference.

Figure 2-15 illustrates a particularly serious case of stray current. In the figure, Pipeline "A" is equipped with a cathodic protection system. Pipeline "B", of other ownership, passes close to the cathodic protection anode bed on Pipeline "A" and then passes under Pipeline "A" without touching it. Under this condition, part of the current being discharged from the anode bed is picked up by Pipeline "B". This current then flows along Pipeline "B" toward the point of crossing where it discharges through the earth to Pipeline "A" in order to complete the circuit. At this point-of-crossing discharge area, Pipeline "B" is anodic and corrodes.

The type of situation illustrated by Figure 2-15 is one that should never knowingly be allowed to exist. Some of the worst instances of this nature have occurred when cathodic protection was installed not knowing that a pipeline of other ownership existed in the vicinity. There have been cases of such instances where the interfered-with pipeline has failed within weeks after the cathodic protection system was placed in operation.

HVDC Systems

Stray currents associated with high voltage direct current (HVDC) electric transmission systems may not demonstrate any particular pattern on recording instrument charts. Under certain conditions, however, stray current effects can be intense over, usually, short periods of time. This is illustrated by Figure 2-16 showing the basic elements of an HVDC system under (A) normal operations and (B) emergency operation.

In normal operation (bipolar mode) shown in part (A) of Figure 2-16 note that the two overhead conductors will be carrying very close to the same amount of current. Automatic equipment keeps the load balanced between the two halves of the system to accomplish this. Any unbalance current (typically quite moderate as shown) will flow along the earth path between grounding electrodes at the ends of the system. This small amount of unbalance current will seldom have a serious stray current impact on other underground structures in the area. This is because grounding electrodes are normally built so as to be separated from other structures and are designed to have low resistance to earth in order to accommodate the full load current of the system. The unbalance current can, as shown, be flowing in either direction through the earth path. If this small unbalance current should have an effect on underground systems in the vicinity of the electrodes, recording instrument charts of the affected underground system voltage to earth would not necessarily show any particular repetitive pattern depending, however, on the operating procedures of the particular HVDC system.

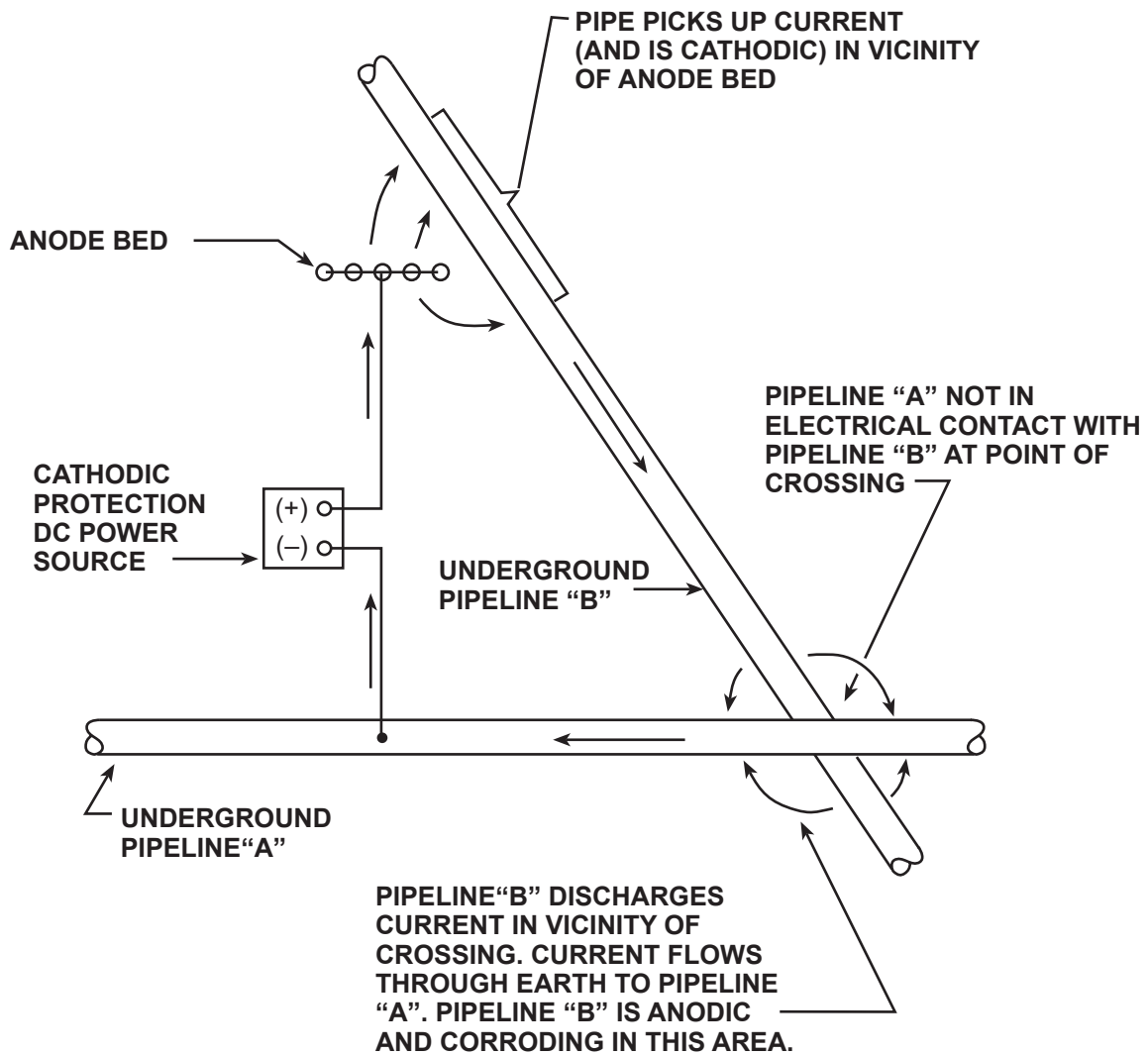

**STRAY CURRENT CORROSION
FROM CATHODIC PROTECTION SYSTEM**

FIGURE 2-15

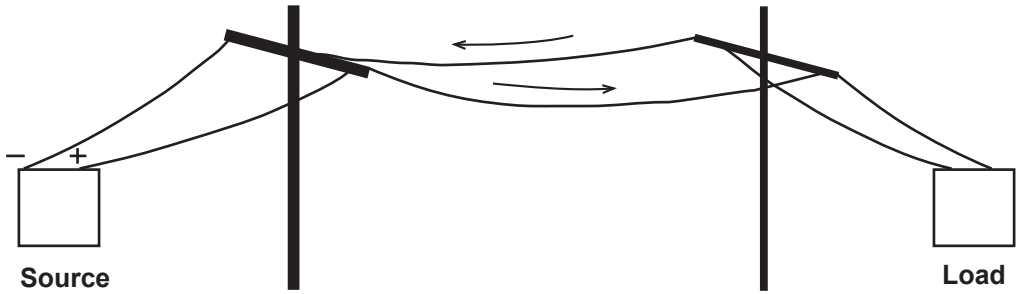

Bipolar Operation
No Current in the Earth

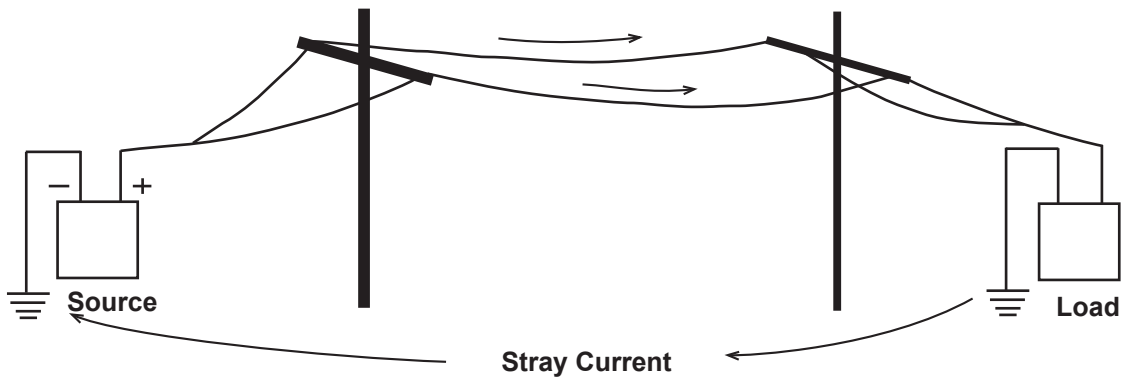

Monopolar Operation
Showing Earth

HIGH VOLTAGE DC TRANSMISSION LINE

FIGURE 2-16

Conditions are quite different in the monopolar mode of HVDC system operation shown in part (B) of Figure 2-16. This illustrates what happens if one half of the HVDC system is out of service because of an emergency or for maintenance.

When this occurs, the entire current flows through one conductor in one direction and through the earth in the other direction. This is why the HVDC system grounding electrodes are designed to carry full system load current; to do this, they have to be massive affairs.

It is under monopolar HVDC system operating conditions that the greatest chance of stray current effects is possible on other underground systems especially in the vicinity of the grounding electrodes. This is as shown on part (B) of Figure 2-16 which shows the direction of stray current flow with a break in the upper conductor of the figure. But if the break were in the lower conductor, the stray current flow would be in the opposite direction. Thus two differing patterns of stray current effect are possible.

Depending on geological earth conditions in the vicinity of a grounding electrode, the radius of the area around an electrode within which stray current pick-up or discharge may be expected can be measured in miles under monopolar operating condition. This is because the driving voltage forcing the current to flow through the grounding electrode resistance will be higher under the monopolar than bipolar operation.

Operators of HVDC systems do their best to keep the length of time that a monopolar condition exists to as short a time as possible.

An HVDC system is considered a static source since large fluctuations of current generally do not occur, even under monopolar operation.

Typical Dynamic Stray Current Sources

DC Transit Systems

Some types of transit systems which are DC powered operate with an electrically isolated positive conductor to the car or train but use the rails as a negative return conductor. Where the rails are in contact with earth, part of the return current leaves the rails and enters the earth. This earth current is the "stray" current. Where an underground structure happens to be following the same path, it picks up some of this stray current as described earlier. An example is illustrated by Figure 2-17.

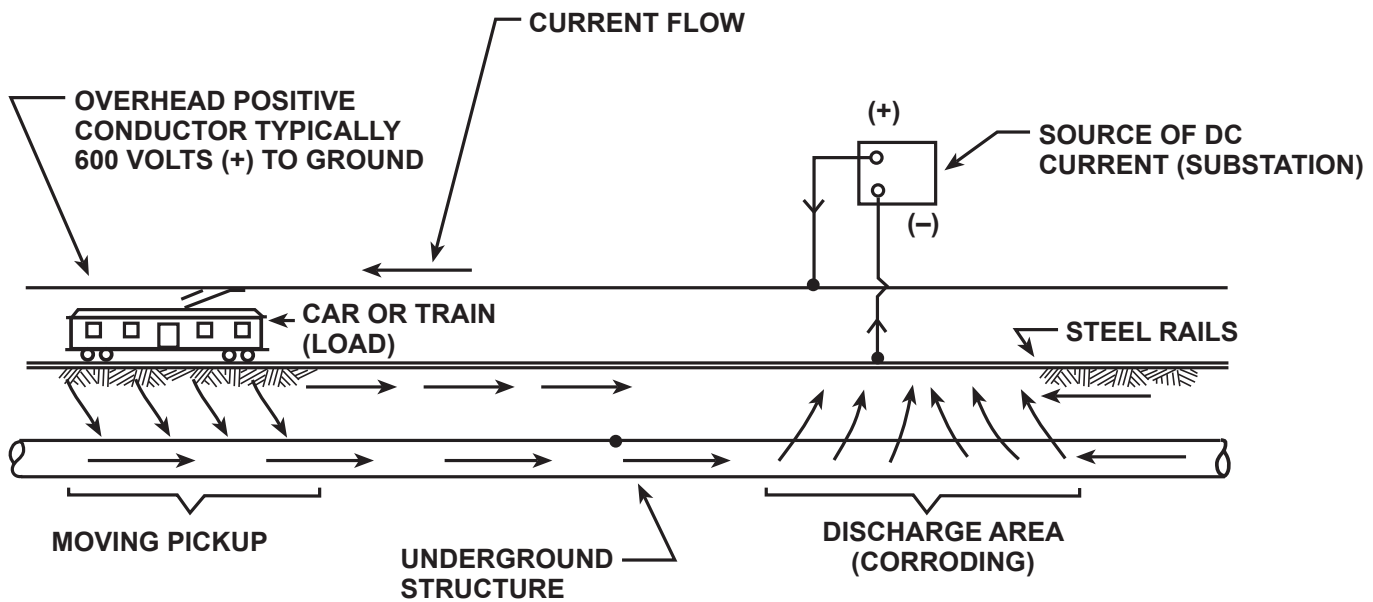

DC TRANSIT SYSTEM AS A SOURCE OF STRAY CURRENT CORROSION

FIGURE 2-17

A well maintained transit system will have the rails on high resistivity ballast or concrete invert. This increases the resistance to earth and reduces the current discharge to the parallel earth path. All-welded rails or mechanical joints in the rails that are equipped with bond cables across the joints keep the rail resistance as low as practical. A poorly maintained transit system, on the other hand, will cause a greater amount of the return current to follow the earth and thus increase the corrosion hazard on underground structures in the area.

DC Mining Operations

Were DC power is used for underground mining operations (mining cutters, ore transport trackage, accessory equipment, etc) the basic stray current problem can then be generally similar to that described for DC transit systems. It is another example of dynamic stray currents. This is as illustrated by Figure 2-18.

Whereas the existence of a transit system is obvious, this is not necessarily the case with mining operation - particularly so with a cross country pipeline which could be some distance from surface facilities associated with the mine. Although DC substation equipment will usually be located at the mine entrance (and will be obvious) there may be additional DC substations located underground. These are not obvious - - unless one finds an AC power cable going underground for no good apparent reasons and then deduces that it may be going to an underground substation.

As shown in Figure 2-18, the current pick-up areas on a structure such as a pipeline move as the DC power-using equipment moves, whereas the current discharge area tends to be concentrated in the area(s) of the substation(s). This can be complicated, however, by occasional moving of substations to new locations as the pattern of mining operation changes. But by keeping tabs on the locations of all substations (once it is discovered that they are a problem), one will know where to expect corrosion problems.

Just to make life more difficult for the corrosion worker, it is possible to encounter DC mining operations where it is the positive (+) side of the DC power supply that is grounded to the rail system while the insulated side of the distribution system is negative (-). To visualize the effect of this, just reverse the direction of all current flow arrows on Figure 2-18 Now there will be concentrated areas of current pick-up on a structure such as a line in the vicinity of substations while the current discharge areas (with attendant corrosion) move as the underground DC power-using equipment moves. This makes it that much more difficult to predict where the worst stray current problems may be expected.

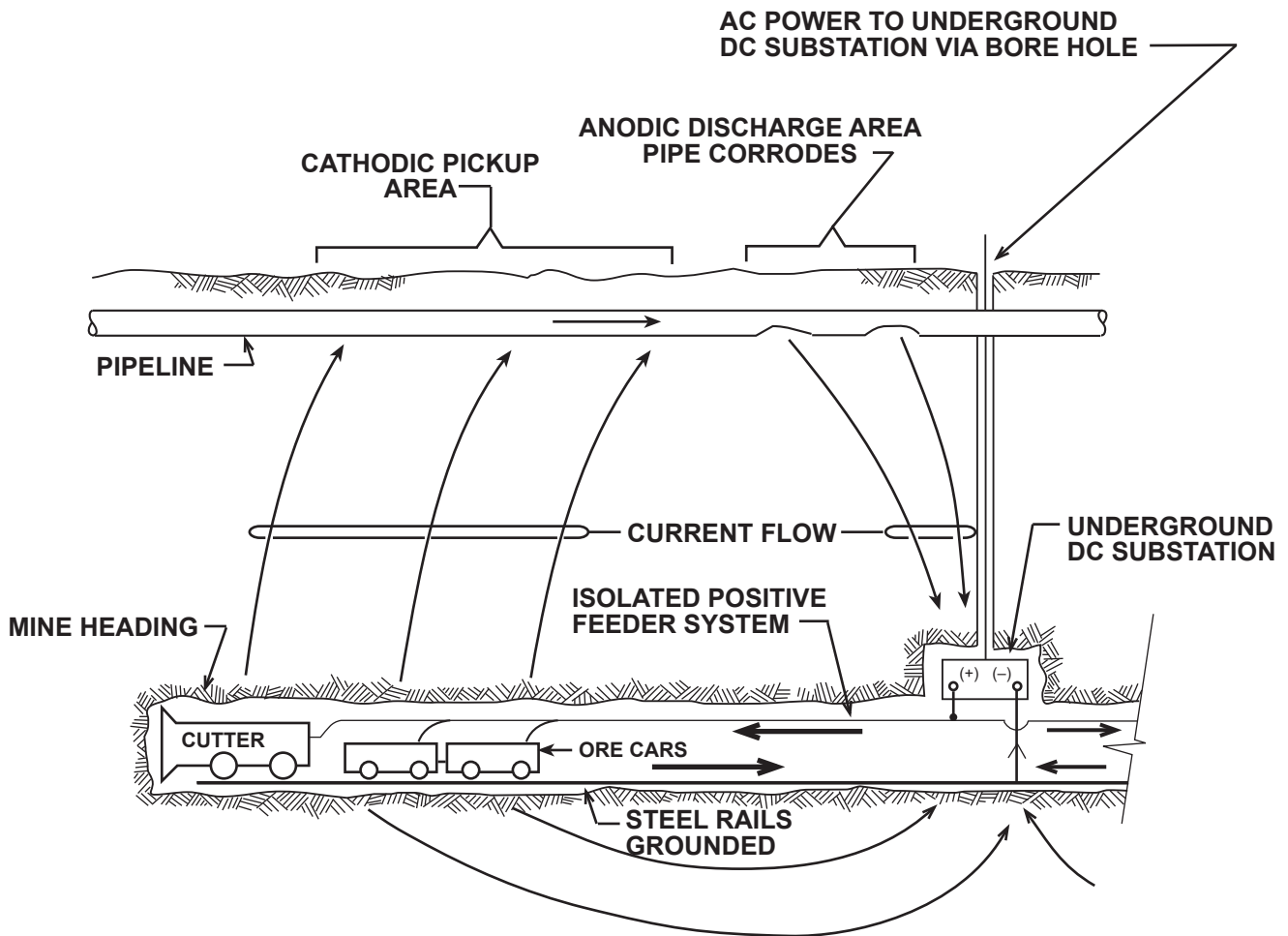

CORROSION BY STRAY CURRENT FROM DC MINING OPERATIONS

FIGURE 2-18

DC Welding Operations

This is another example of dynamic stray current. Where DC welding is performed with one conductor connected directly to the piece being welded while the other conductor is connected to the welding electrode holder, there is little chance for significant stray current. However, on major plant construction projects, shipyards, etc, the current may come from a DC welding generator station some distance from the point where the welding is being performed. To reduce the amount of cable required, the structure itself may serve as a current-carrying member between the generator station and point of work just as do the rails in a DC transit system. Where part of the structure is buried or submerged, there can be parallel earth paths with current pick-up and discharge areas; the linear distance between welding generator station and point of work may be small enough and the conductivity of the structure so great, however that this may not be a serious factor during the construction period - - but should always be a point of consideration.

What can result in serious stray current damage, is DC welding on a part of the buried structure which is not electrically connected to the rest of the structure. This is illustrated by Figure 2-19.

With the structure on both sides of the gap in contact with earth, welding, current can pass through the earth to complete the circuit. With a small gap the current discharge may be concentrated in a relatively small area. With the high currents typically associated with welding, corrosion damage can be rapid. There have been cases where failures have occurred on critical elements of structures before initial construction was completed.

FACTORS AFFECTING THE RATE OF CORROSION

General

The rate of corrosion is directly proportional to the amount of current leaving the anode surface. This current is related to both potential (voltage) between the anode and cathode and the circuit resistance.

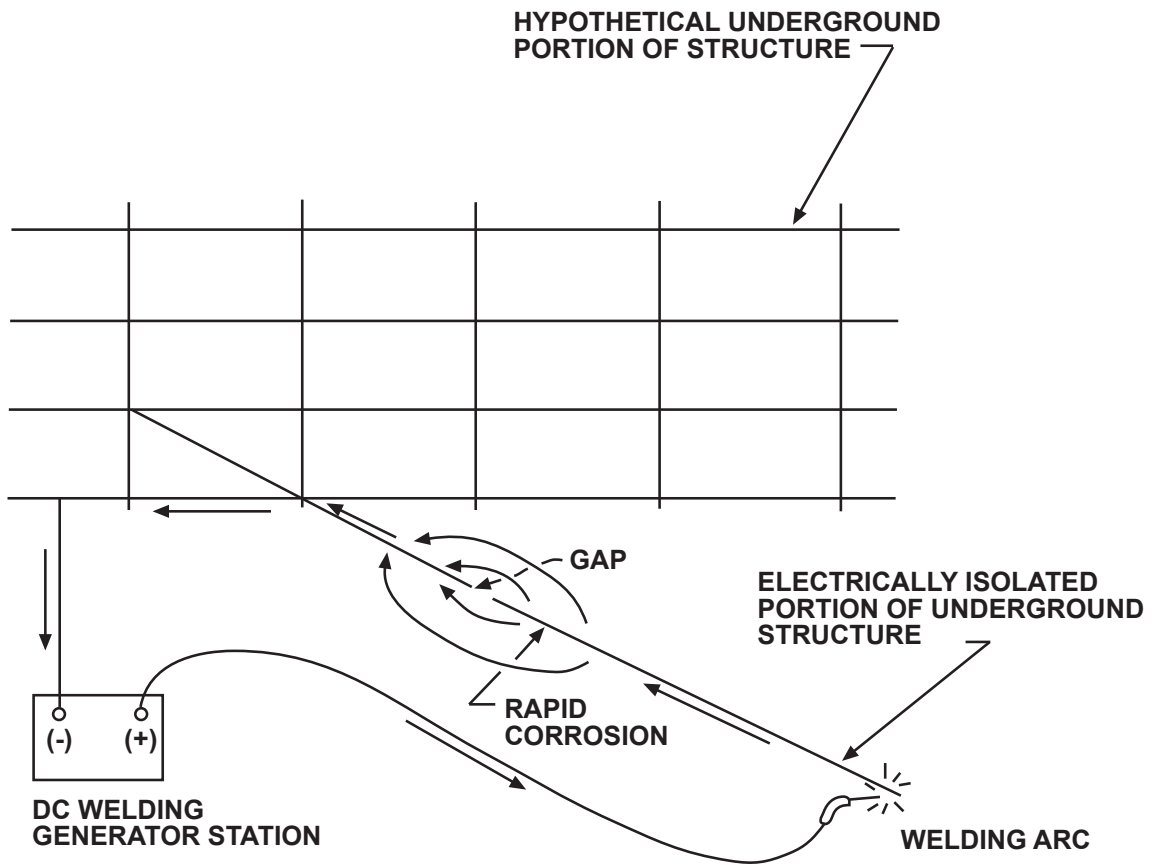

**CORROSION BY STRAY CURRENT
FROM DC WELDING OPERATIONS**

FIGURE 2-19

Voltage, resistance, and current are governed by Ohm's Law:

Where:

I = Current (Amperes or Milliamperes)

E = Voltage (Volts or Millivolts)

R = Resistance (Ohms)

Essentially, Ohm's Law states that current is directly proportional to the voltage and inversely proportional to the resistance.

Polarization

Polarization is a retardation in the rate of corrosion, or current flow, caused by a reduction in the voltage difference or an increase in resistance between the anode and cathode. There are two types of polarization, activation and concentration.

Activation polarization is inherent in the reaction itself. Essentially, it represents the speed at which electrons can be transferred from the cathode surface to a cation (ions attracted to the cathode) such as hydrogen. Consequently the rate of hydrogen evolution, and hence the rate of corrosion, differs for different metals. As time progresses, hydrogen may adhere to the surface of the cathode, thus reducing the rate of electron transfer to hydrogen ions in the electrolyte.

Concentration polarization represents a depletion of cations adjacent to the cathode surface. If hydrogen is being evolved, for example, the availability of hydrogen ions around the cathode may be reduced, thus reducing the rate of corrosion.

The evolution of hydrogen may cause a film of hydrogen to develop over the cathode surface. Likewise, corrosion products may adhere to the anode surface. Both of these reactions cause an increase in the anode to cathode resistance, and thus a reduction in the rate of current flow.

Electrolyte Resistivity

As was mentioned above, corrosion obeys Ohm's Law.

Consequently, structures placed in high resistivity electrolytes tend to corrode more

slowly than those in low resistivity environments. For this reason, salt water is generally more corrosive than fresh water.

Voltage Difference Between Anode and Cathode

This is particularly applicable to dissimilar metal couples. The greater the voltage difference between two metals, the greater the rate of corrosion (again, after Ohm's Law). Of course, the rate of corrosion may be reduced considerably from the initial rate due to polarization. Stainless steel polarizes much faster than copper, for example, when each are connected to carbon steel. Consequently, the corrosion rate between carbon steel and stainless may end up being much less than that between carbon steel and copper, even though the initial voltage differences may be about the same.

Anode/Cathode Ratio

The relative area between the anode and cathode greatly affect the rate at which the anode corrodes. If the anodic area is small in relation to that of the cathode (a galvanized fitting in a brass pipe for example - Figure 2-20A), the anode will corrode rapidly. This is because the corrosion current is concentrated in a small area. Also, the large cathode may not polarize easily, thus maintaining a high rate of corrosion.

When a large anode is connected to a small cathode (a brass fitting in a galvanized pipe for example - Figure 2-20B), corrosion is spread out over a large area. Thus, the concentration of corrosion current is not so dense, and the anode corrodes more slowly. Polarization may play an important role here, too. The small cathode may polarize rapidly, reducing the rate of corrosion current flow.

Effect of the Metal Itself

Different metals corrode at different rates because of the difference in the amount of energy stored in them. The rate is expressed by Faraday's Law:

$$W = K \times I \times T$$

Where:

W = Weight Loss in One Year

K = Electrochemical Equivalent in Pounds Per Ampere Per Year

I = Corrosion Current in Amperes

T = Time in Years

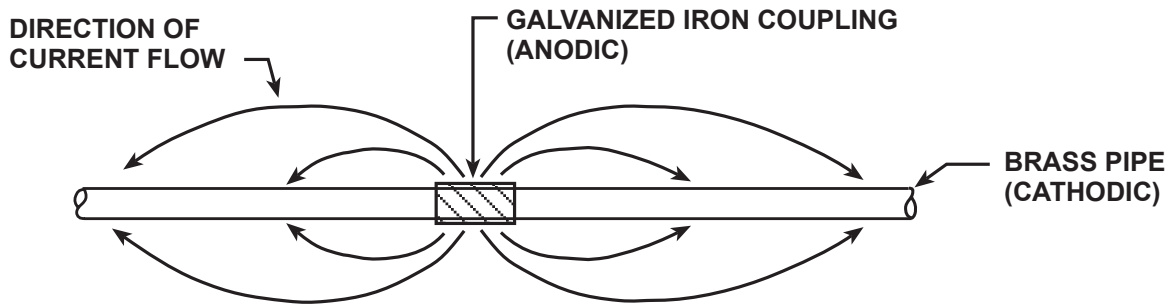

A - SMALL ANODE - LARGE CATHODE (SERIOUS CORROSION)

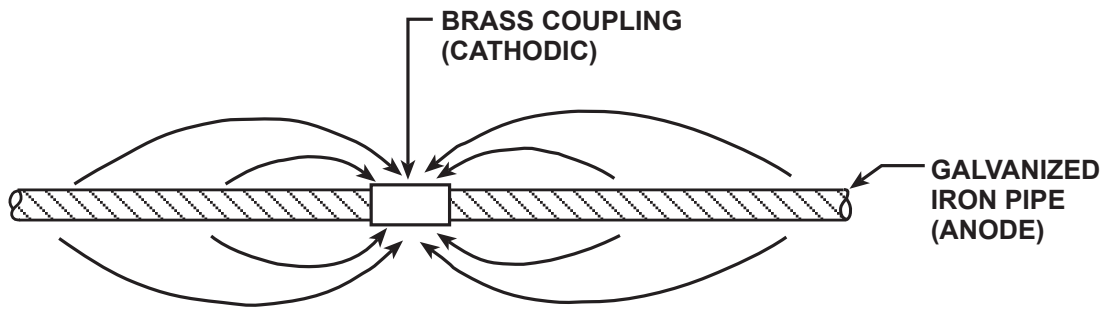

B - LARGE ANODE - SMALL CATHODE (LESS INTENSE CORROSION)

ANODE-CATHODE SIZE RELATIONSHIP

FIGURE 2-20

Table 2-2 gives the electrochemical equivalent stated in grams per coulomb, and consumption rates of some typical metals in pounds per ampere-year. This is the weight of metal that will be corroded away by one ampere of direct current continuously discharging from a metal into a surrounding electrolyte for a period of one year.

Table 2-2 also includes the volume of the metal which will be removed per ampere-year. This is the critical figure as it illustrates the amount of metal that will be removed from, for example, a high pressure steel pipeline for a given amount of current.

As an example, if a steel pipeline were discharging only 1 milliamp (0.001 ampere) at a given spot, the volume of iron removed per year would be 70.81 cubic inches per ampere year x 0.001 ampere or 0.07081 cubic inches. If concentrated in small areas (such as at defects in an otherwise good coating), this is sufficient to cause approximately 4 one quarter inch diameter holes in a $\frac{3}{8}$ inch thick pipe wall in a year's time. This example is given to show how important it is to control the discharge of even very small amounts of current from an underground steel structure into surrounding earth or water.

From the table it will be seen that the corrosion rates and volumes of metal removed vary considerably. Of the metals shown, lead has the greatest corrosion rate and the greatest volume loss. This emphasizes the critical need for effective corrosion control on, for example, lead sheaths on underground power and telephone cables. Formerly, lead sheaths were used widely but new construction favors plastic sheathing.

Passivation of the Metal Surface

The ability of a metal to form a protective film greatly affects the rate at which it will corrode. The film is often an oxide and is generally invisible. The development of such films is the reason for the corrosion resistance of such metals as aluminum, chromium, stainless steels, lead and others.

When a film breaks down, but is immediately restored, passivity continues. Should the film not be restored, as in the case of a crevice in stainless steel where there is little or no oxygen, then rapid corrosion may occur. Pitting corrosion will frequently take place at a point where film breakdown is sustained.

SUMMARY

The corrosion control worker needs to understand what causes corrosion. This requires

TABLE 2-2**CONSUMPTION RATES OF TYPICAL METALS**

Metal	Electrochemical Equivalent (Grams per coulomb)	Consumption Rate (Pounds per Ampere-year)	Volume of Metal Consumed (Cubic inches per Ampere-year)
Carbon* (C ⁺⁺⁺)**	0.4149×10^{-4}	2.89	36.99
Aluminum (Al ⁺⁺⁺)	0.9316×10^{-4}	6.48	69.99
Magnesium (Mg ⁺⁺)	1.2600×10^{-4}	8.76	141.47
Iron (Fe ⁺⁺)	2.8938×10^{-4}	20.12	70.81
Nickel (Ni ⁺⁺)	3.0409×10^{-4}	21.15	67.06
Copper (Cu ⁺⁺)	6.5875×10^{-4}	45.81	142.89
Zinc (Zn ⁺⁺)	3.3875×10^{-4}	23.56	90.87
Tin (Sn ⁺⁺)	6.1502×10^{-4}	42.77	162.43
Lead (Pb ⁺⁺)	10.736×10^{-4}	74.65	181.68

* Carbon is not strictly classified as a metal but as a metalloid -- but subject to consumption as a metal.

** Each metal is followed by its chemical symbol. The number of (+) signs following the symbol indicates the valence (a chemical term) for a typical anode reaction. The electrochemical equivalents are calculated on the valence shown. Other valences may apply under certain conditions for some metals.

knowledge of the electrochemical principles involved and the various mechanisms which create corrosion cells. The factors that affect the rate of corrosion need to be understood, too. Armed with this knowledge, corrosion control personnel are ready for the next step - corrosion control. Methods of corrosion control are discussed in the next chapter.

Chapter 3 - Corrosion Control Methods

INTRODUCTION

In Chapter 2, Corrosion Fundamentals, some of the various sources of galvanic corrosion and stray current corrosion were discussed. In this chapter, we will outline various methods and procedures that are in common usage for controlling the two general types of corrosion.

SUMMARY OF CORROSION CONTROL METHODS

Following are the types of corrosion control methods applicable to galvanic corrosion problems and to stray current problems. It will be noted that some of these methods are applicable to either category of corrosion problems.

For Galvanic Corrosion Control:

- Coatings
- Cathodic protection
- Isolating joints

For Stray Current Corrosion Control:

- Coatings
- Cathodic protection
- Isolating joints
- Drainage bonds and forced drainage bonds
- Reverse current switches

Each of the several types of corrosion control will be described under following headings.

COATINGS

It has been learned in the preceding chapter that wherever direct current flows from an underground metallic structure into a surrounding electrolyte (earth or water), the metal will be consumed (corroded) at the points of current discharge. Following simple logic, if an isolating barrier (a coating) were to be placed between the metal and the surrounding electrolyte, corrosion current could not flow and there would be no loss of

metal. This is absolutely true.

Before we decide that coatings are the ultimate answer to corrosion control on underground structures and that we need look no further, it must be understood that there is a very important catch to the preceding statements on the use of coatings. It is this. If a coating is to perform as stated, it must be perfect and it must remain perfect. On extensive underground structures such as pipelines, it is not economically or practically feasible to apply an isolating coating that will meet these criteria.

To illustrate the difference between a perfect coating and one that has imperfections, Figure 3-1 shows the difference in corrosion performance under the two conditions. The corrosive environment shown is that for a structure in dissimilar soils as was first shown by Figure 2-8 of Chapter 2 under the heading, Dissimilar Soils.

Part "A" of Figure 3-1 shows that even though there is a galvanic voltage difference of 0.2 volt between Soil "A" and Soil "B", the isolating barrier interposed by the perfect coating prevents current flow to or from the pipe to complete an electrical circuit. With no current flow to or from the pipe, there can be no corrosion on the pipe exterior surface.

Part "B" of Figure 3-1 shows what happens when an otherwise excellent coating develops pinholes, scrapes, or other imperfections (known as coating "holidays") which can expose small areas of pipe surface to the surrounding earth. With the exposed areas at coating flaws, there is now a path for current to flow as a result of the existence of the dissimilar soil galvanic corrosion cell driving potential shown. Current will now discharge from the pipe at coating flaws in anodic areas (and cause corrosion at these locations) and will return to the pipe at coating flaws in cathodic (non-corroding) areas.

In Chapter 2 it was pointed out that one of the factors controlling the amount of corrosion current flowing (and amount of metal loss) in a given galvanic corrosion cell is circuit resistance. In Part "B" of Figure 3-1, the presence of the isolating coating, even though flawed, will substantially increase the total circuit resistance. This means that the total galvanic cell current flow will be substantially less. This means, further, that the amount of metal corroded away during a given period of time will be much less than would occur if the structure were uncoated under otherwise similar conditions.

Do not conclude from the preceding paragraph that corrosion of a coated structure is not serious even with imperfections in the coating. What happens is this. The corrosion cell current flowing, even though reduced, is concentrated at the metal exposed at holes

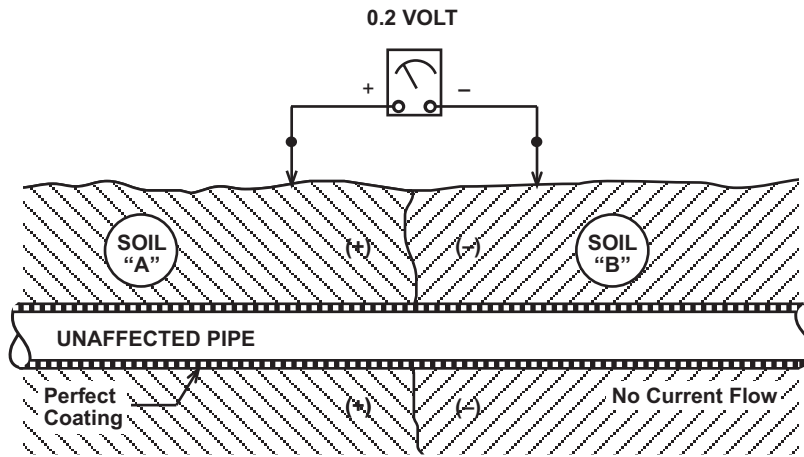

PART A – PIPE WITH PERFECT COATING IN DISSIMILAR SOILS

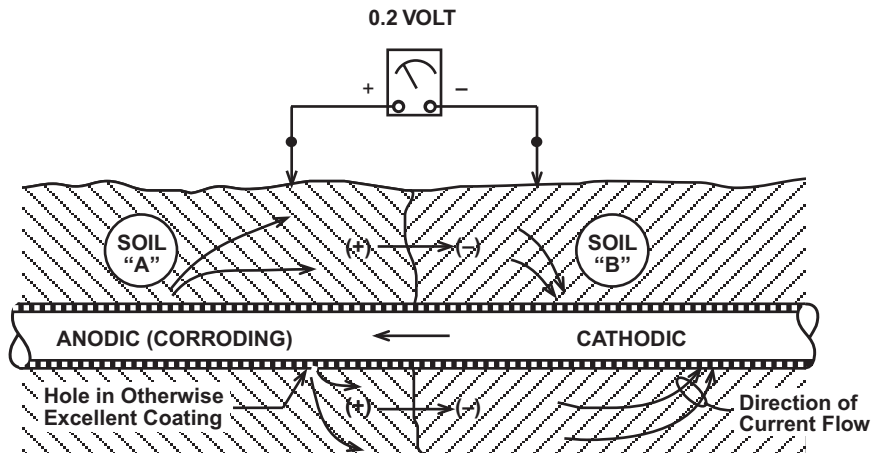

PART B – PIPE WITH FLAWED COATING IN DISSIMILAR SOILS

USE OF COATING ON UNDERGROUND STRUCTURE

FIGURE 3-1

in the coating. This means that at current discharge points in anodic areas the current discharge density in terms of milliamps per unit area can be higher than would be the case if the same structure were entirely bare. Because of this, a structure such as a coated high pressure pipeline can (in the absence of other corrosion control measures) experience its first leak sooner than would have been the case if the pipeline had been laid bare. This can be true even though the total metal loss is less than on the bare pipe because of the reduced total corrosion cell current.

Some of the factors that operate to prevent applying and keeping a perfect coating on a large underground structure are:

1. Undetected handling damage during construction.
2. Stones or debris in backfill that force their way through the coating.
3. Soil movement or structure movement with pressure changes (pipelines).
4. Tree roots working through coating.
5. Excavations by others which expose the structure and damage the coating with excavation equipment.

Even with these hazards, the use of suitable good coatings and good application and maintenance practices can result in a coating which is initially 99.9% perfect or better -- and which will decrease only a few percentage points with time. This indicates that the majority of the structure surface will be free of corrosion damage. It is the remaining surface area that needs additional corrosion control measures.

In addition to reducing the total corrosion hazard from galvanic corrosion cells, coating on a structure will also reduce stray current damage by increasing the circuit resistance. This reduces the amount of current pickup. Even so, the total stray current can be much greater than that resulting from galvanic corrosion cells. At points of stray current discharge on coated structures, the concentration effect at coating imperfections as described earlier, can be much more intense than under galvanic corrosion cell exposure with very rapid structure penetration. Again, additional corrosion control measures are needed to supplement the coating.

Further detailed treatment of coatings on underground structures is included in the Chapter 4 of the Basic Course.

CATHODIC PROTECTION

This is a widely used and effective method of corrosion control. It can be used to control corrosion on bare underground structures. It is commonly used as a supplement to coatings on underground structures. For pipelines carrying hazardous materials, for example, the use of coatings and cathodic protection is required by Federal regulations on all new construction. And on existing facilities in this category, coated or bare, cathodic protection in corroding areas is similarly required by regulations.

The following material under this heading will discuss (1) the theory of cathodic protection and the way it works, (2) the types of cathodic protection in common usage, and (3) the applicability of cathodic protection to galvanic corrosion cell conditions and to stray current exposure conditions.

Theory of Cathodic Protection

The basic theory of cathodic protection is simple. In Chapter 2 it was demonstrated that an unprotected underground structure will have anodic areas where current discharges to earth and corrodes the metal and will have cathodic areas where current flows from the environment onto the structure. Most importantly, there is no corrosion in the cathodic areas.

Now if, by some means, the anodic areas could be converted to cathodic areas, the corrosion should stop. This is exactly what cathodic protection does. Direct current is forced to flow into the earth through an anode connection outside the structure and then through the earth to the structure to be protected. The amount of current forced to flow onto the structure is adjusted to a level which will nullify current discharge in anodic areas and result in net current collection in these areas. What had been anodic areas are now cathodic and the areas which were originally cathodic are still cathodic.

In theory, once the entire exposed metal surface of the structure is collecting current from the conducting environment, the entire structure becomes a cathode and corrosion stops. Hence the name "cathodic protection" for this method of corrosion control.

How Cathodic Protection Works

An illustration of how corrosion works in principle is shown by Figure 3-2.

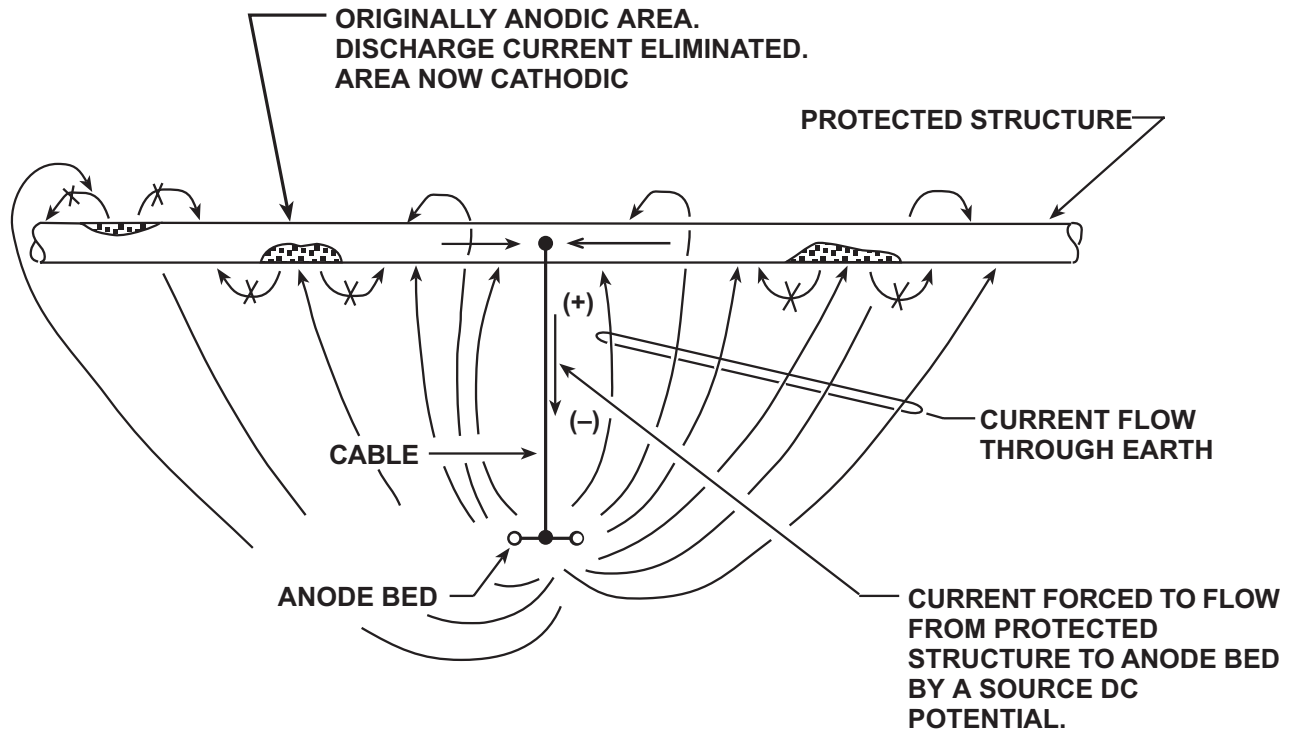

HOW CATHODIC PROTECTION WORKS

FIGURE 3-2

As can be seen from the figure, some source of DC potential (discussed later) forces current to flow through a wire or cable connection from the protected structure to the anode bed, then through the earth to all metal surfaces of the structure which are exposed to surrounding earth or water, and finally along the structure itself to the drainage cable connection to complete the circuit. It should be noted that current which flows from an underground structure through a metallic connection (such as the cathodic protection drainage cable) does not cause corrosion of the structure.

In Chapter 2, it was established that any metal or metalloid that discharges direct current into a conducting electrolytic environment (earth or water) corrodes. This, then, means that the anode bed of Figure 3-2 should corrode - and it does. Accordingly, it can be said that in one sense, cathodic protection does not eliminate corrosion; it simply transfers the corrosion from the structure being protected to the cathodic protection anode bed. The anode bed can be replaced periodically without endangering the working structure. Further, anode beds are typically designed to permit discharge of the desired amount of current for a period of years before replacement is necessary.

The amount of current to be discharged from any single cathodic protection installation will depend largely on the amount of exposed metal on the structure (or portion of a structure) to be protected by that installation.

At this point, it is important to stress the difference between cathodically protecting an uncoated underground structure and protecting the same structure with a good coating serving as an isolating barrier between structure and adjacent earth or water. If, for example, a bare structure were found to require 100 amperes of cathodic protection current to attain complete protection, the same structure with a good coating might require less than one ampere for the same degree of protection.

To take an actual case history, a 70-mile length of 26-inch natural gas pipeline with an excellent coating buried in a low resistivity corrosive environment could, during its early life, be completely cathodically protected throughout its length with the current from a single flashlight battery. Had this pipeline been bare, the current required would have been in the order of 2,500 amperes under the most optimistic conditions based on a current consumption of only one milliamperere per square foot of bare surface (a typical minimum amount for a new-steel bare structure).

Note that there is no fixed ratio that can be used between current required to protect a bare structure and current to protect the same structure if coated. It depends very largely on the quality of the coating used, the type of structure, and the design of the

cathodic protection installations used.

The preceding paragraphs do demonstrate, however, that cathodic protection and coatings, used together, comprise an effective team. The coating provides corrosion protection for the bulk of the structure surface while the cathodic protection current seeks out and protects metal exposed to the environment at the inevitable flaws in the coating layer.

Granting that the theory of cathodic protection is simple, the question always arises as to how it can be known that full cathodic protection has actually been attained on an underground structure. There are several criteria that can be used. These are discussed in detail in the intermediate course. At this point, however, one criterion in common usage should be mentioned. This is the measurement of the potential between the structure and a standard reference electrode (such as a copper-copper sulfate reference electrode) contacting the adjacent environment. In the case of steel structures, such potential measurements made before applying cathodic protection will typically (depending on the structure) be in the range of -0.2 volt to -0.7 volt with respect to a copper-copper sulfate reference electrode. With the application of cathodic protection current, these structure potentials will move in the more negative direction. When values of at least -0.85 volt are reached at all points, it is a good practical indication that a sufficient amount of cathodic protection current has been applied to stop corrosion. Note the words, "good practical indication". It is always possible that there can be local unusual conditions where less than full protection is reached in small areas -- these may not be revealed by the potential measurements taken. With good structure construction practice and effective coatings (if coatings are used), these "unusual" situations or anomalies should be at a minimum.

Types of Cathodic Protection

Figure 3-2 discussed under the preceding heading indicated that direct current was forced to flow along the wire from the cathodically protected structure to the anode connection or anode bed. Forcing current to flow along a wire implies the presence of a driving potential (or voltage). This will always be present as part of a cathodic protection installation.

There are two general types of cathodic protection installation which differ primarily in the manner in which a voltage is obtained to force cathodic protection current through its circuit. These two types are commonly referred to as galvanic (or sacrificial) anode cathodic protection and impressed current cathodic protection. These are described

below.

Galvanic (or Sacrificial) Anode Cathodic Protection

When we use the word "galvanic", we might conclude that a galvanic potential is what forces the current to flow. This is, in fact, the case. This type of cathodic protection depends on the voltage difference between dissimilar metals to cause a current to flow.

Actually, practical use is made of a dissimilar metal corrosion cell as was discussed in Chapter 2. In this practical use, however, a dissimilar metal cell is needed that has a substantial driving potential (voltage) between the two metals. For example, if a steel structure is to be protected, the practical galvanic series (Table 1, Chapter 2) indicates that the initial voltage difference between magnesium alloy and steel could range from 0.8 volt to 1.4 volts (depending on the condition of the steel). This voltage difference can be used to advantage since, in the steel-magnesium couple, the steel is cathodic and the magnesium is anodic.

With the above in mind, the essentials of a galvanic anode cathodic protection installation are shown by Figure 3-3. The anode material can be magnesium (as shown) or may be zinc (lower cell voltage -- used in low resistivity soils as a general rule) or may be aluminum (lower cell voltage -- particularly useful in a sea water environment). The chemical backfill shown in the figure is normally used with buried magnesium or zinc anodes to obtain uniform anode consumption and maximum anode efficiency. The anode material is normally available in cast shapes of various sizes to fit the requirements of differing galvanic anode cathodic protection installation designs.

For very small current requirement at one location, a single galvanic anode may be sufficient. If more current is needed, several anodes may be connected in parallel as shown by the dashed lines in the figure. Whatever the current output designed for a particular installation may be, the design typically provides for sufficient anode material to discharge design current for a selected period of years before replacement is necessary. This is based on the electrochemical equivalent of the anode metal used (as discussed in Chapter 2) with allowances for anode efficiency and for replacement before the anodes are completely gone.

Galvanic anode installations have certain advantages such as:

1. They are self-powered. No dependence on outside sources of power.

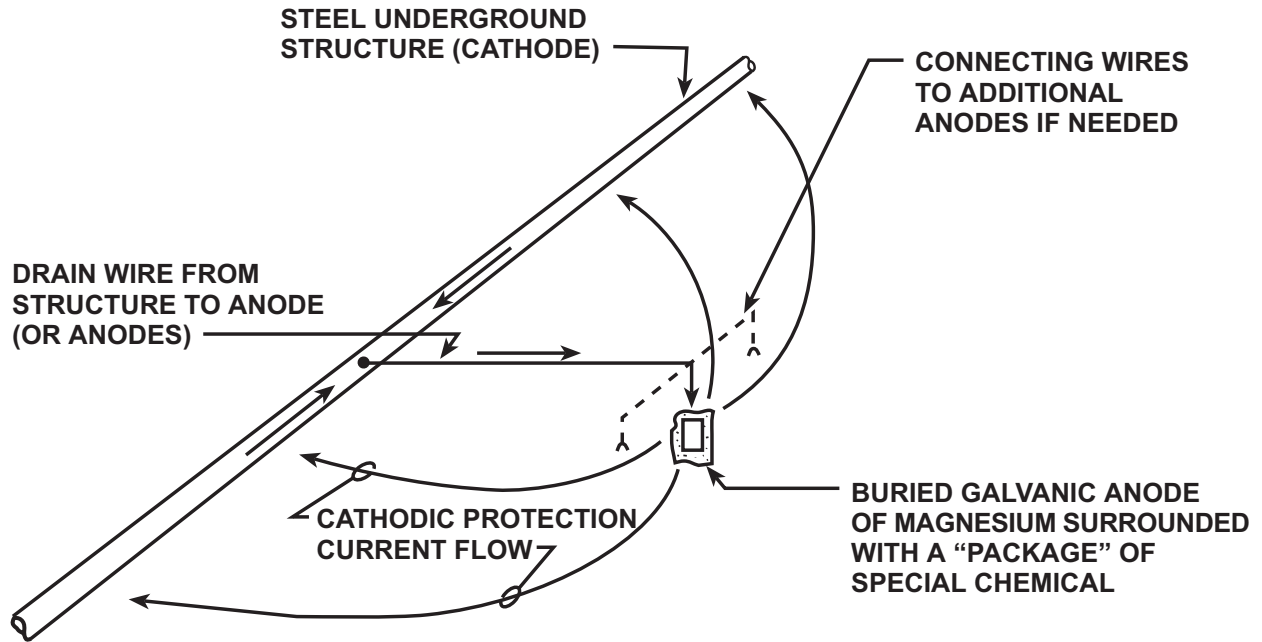

GALVANIC ANODE CATHODIC PROTECTION

FIGURE 3-3

2. Low maintenance requirements.
3. Minimum probability of stray current interference on other underground structures.

There are also limitations such as:

1. Low driving voltage.
2. Relatively low current output capacity.

Impressed Current Cathodic Protection

Whereas galvanic anode installations are self-powered, impressed current installations utilize a separate source of direct current. The current from this source is impressed on the circuit between the structure to be protected and the anode bed. The essential components of such a system are shown by Figure 3-4.

An AC to DC rectifier is shown as the DC source in the figure. Such devices are widely used in cathodic protection work. Basically, they use DC power from a commercial source (such as 120, 240, or 440 volts, single phase or three phase), step down the voltage, and rectify it to DC. The DC output voltage can normally be adjusted so that the desired current can be forced to flow through a range of circuit resistances. Rectifiers are available with a wide range of current output capacity and DC output voltage.

Although the rectifiers more commonly used are those having a fixed output, once adjusted to suit a specific cathodic protection installation, there are automatically controlled rectifiers with solid state control circuitry. Units can be obtained which will maintain a desired current output with changes in the circuit resistance. Others are available which will maintain a fixed structure to earth (or water) protective potential with changes in the current needed to maintain that potential.

Other sources of DC power can also be used. Among these are engine-generator sets which use (for example) propane or natural gas to power the engine; solar panels which convert sunlight to DC energy; thermoelectric generators which use a fuel source to heat a series of metallic thermal junctions which generate direct current; and (in some areas) windmill-generators which develop the needed DC energy.

Figure 3-4 illustrates one type of anode bed with anodes installed vertically near the surface at a selected design spacing and connected in parallel. The anodes can be installed

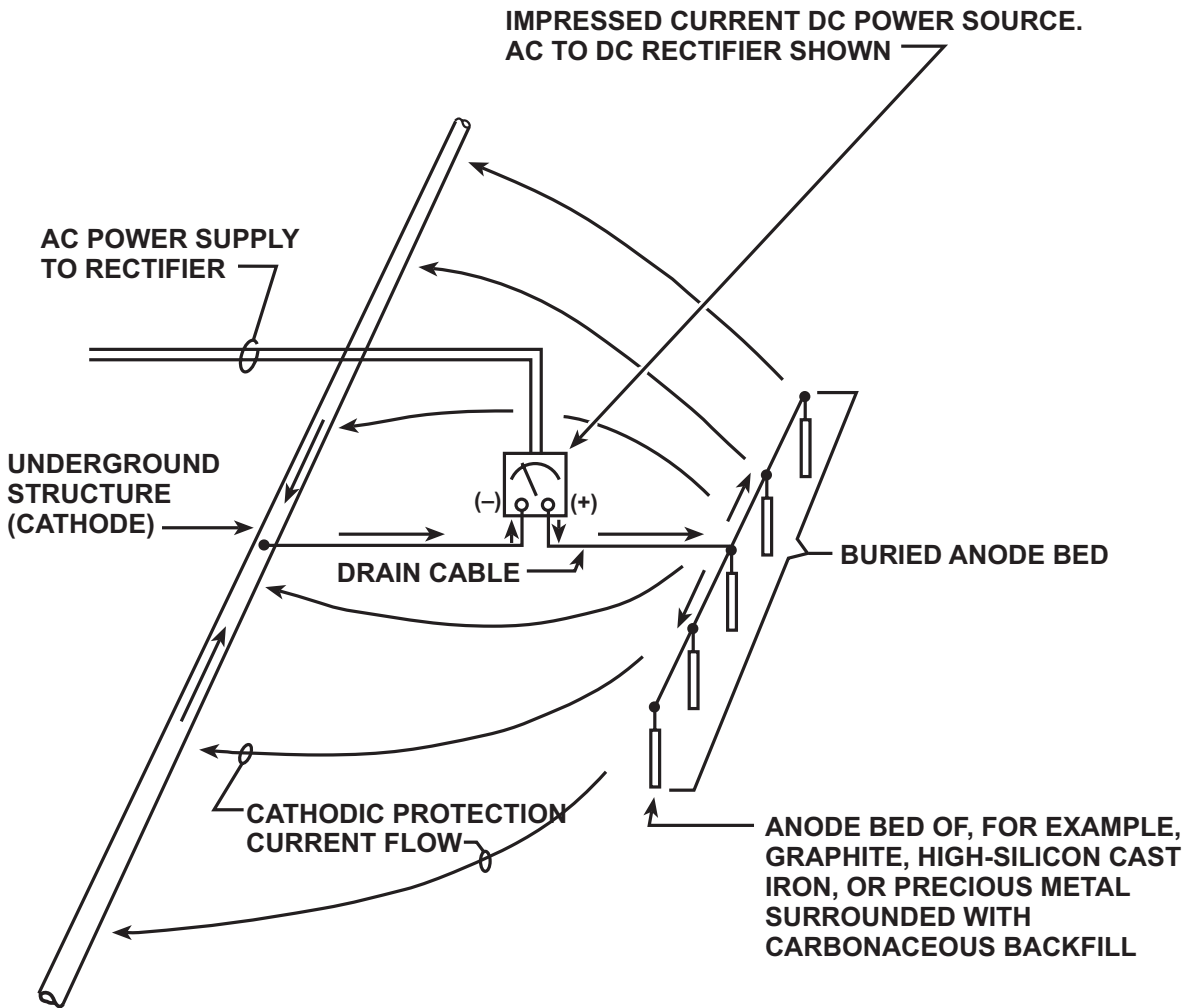

IMPRESSED CURRENT CATHODIC PROTECTION

FIGURE 3-4

horizontally in some installations. The line of anodes can be perpendicular to the structure rather than parallel to it as shown. In still other designs, the anodes may be placed in a single deep hole (sometimes hundreds of feet deep) in order to reach a favorable soil formation or to avoid stray current effects on other underground structures in the area. These are commonly referred to as deep anode beds.

The anodes, since they discharge current, will corrode. In order to attain maximum life, low-consumption-rate materials such as graphite, high-silicon cast iron, magnetite, or precious metals are used. Additionally, such anodes are normally backfilled with a carbonaceous material such as coke breeze or graphite particles which tends to be consumed by the current discharged before the basic anode material is seriously attacked. The usual anode bed design is such that sufficient anode material is provided to last a period of years (such as 25) at the design current output before replacement is necessary.

Impressed current installations have certain advantages such as:

1. A wide range of DC voltage and current output capacities. This provides great flexibility in system design.
2. Single installations which will protect much larger structures (or portions of structures) than is usually possible with single galvanic anode installations.

There are also disadvantages such as:

1. Greater maintenance requirements than for galvanic anode installations.
2. Dependence on availability of a dependable power supply or fuel supply.
3. Continuing cost of energy where AC power or a fuel supply is required.
4. Greater possibility of stray current interference on other underground structures than is the case with galvanic anode installations.

Cathodic protection is applicable to structures subject to galvanic corrosion. It also can be used to offset the effects of lesser stray current effects such as those from relatively remote man-made sources or from telluric currents.

In this introduction to cathodic protection, the details of cathodic protection system

designs were not covered. Further information on the construction and design of such systems is contained in the intermediate and advanced courses.

ISOLATING JOINTS

This method of corrosion control utilizes various isolating devices which are inserted in pipelines (or other structures where applicable) and will block the flow of electrical current without disturbing the functional requirements of the structure itself.

Isolating joints are useful for the following purposes:

1. To separate dissimilar metals.
2. To confine cathodic protection current to a structure (or portion of a structure) to be cathodically protected.
3. To confine and reduce the effect of stray current to manageable proportions (where applicable).

An example of the use of isolating joints is illustrated by Figure 3-5. The application shown is the electrical isolation of a new steel pipe replacement in an old steel pipeline system. In Chapter 2 it was learned that if severe corrosion has occurred on a section of old pipeline and that section is replaced by a piece of new pipe welded into the old line, the piece of new pipe will be anodic and will corrode with relative rapidity because of being electrically joined to adjacent cathodic old pipe sections.

An effective replacement procedure, as illustrated, is to make the replacement with well-coated pipe which is electrically isolated from the adjacent system by use of isolating joints. This nullifies the effect of the new steel - old steel galvanic couple. Corrosion is further controlled on the replacement by use of galvanic anode(s) for cathodic protection of the replacement. The isolating joints serve to confine the cathodic protection current to just the replacement section.

Typically, isolating joints in common usage include but are not limited to, isolating flange sets, isolating compression couplings, proprietary weld-in prefabricated devices, and isolating unions or isolating bushings for threaded pipe assemblies.

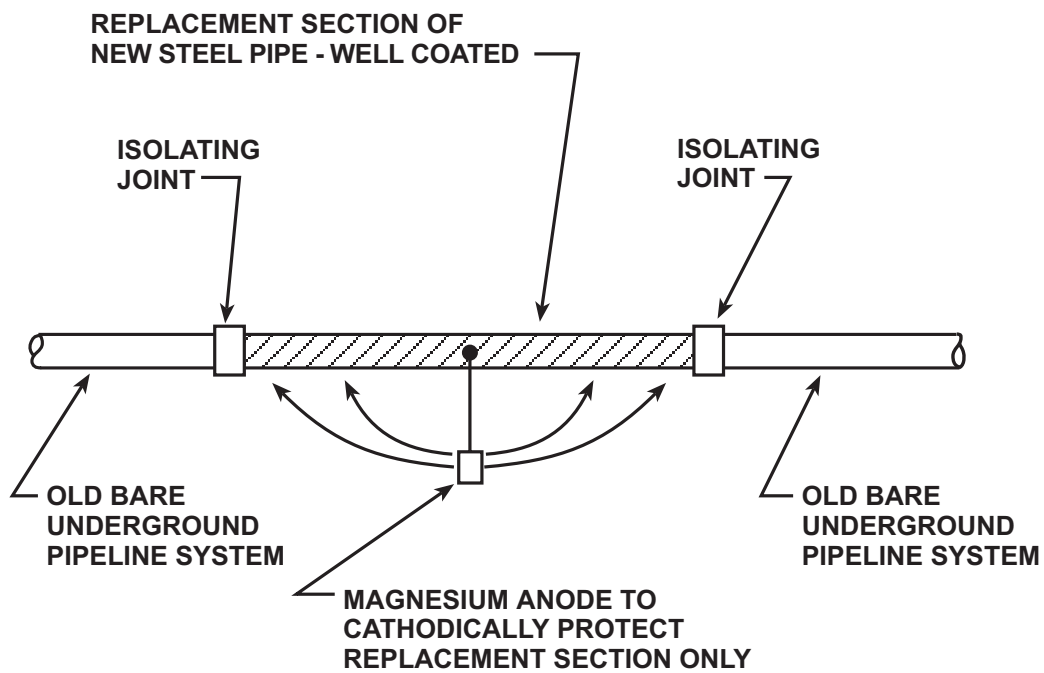

AN APPLICATION OF ISOLATING JOINTS

FIGURE 3-5

DRAINAGE BONDS

This type of corrosion control method is particularly applicable to stray current corrosion problems. Since direct current drained from an underground structure by way of a wire or cable does not corrode the structure, the drainage bond concept is based on providing a metallic path by which stray current discharging from a highly anodic area on an affected structure can return to its source without damage to the structure.

Figure 3-6 illustrates a simple case of the use of a drainage bond to control corrosion on an underground pipeline caused by stray current from a transit system. To be effective, the drainage bond cable must be large enough, and as short as possible, to drain the maximum stray current involved with minimum voltage drop in the resistance of the drainage bond cable itself.

It should be noted that once the drainage bond cable is installed as shown, the resistance to current discharge will normally be less than was the case when current was being discharged from pipeline directly to earth. This means that the stray current pickup in pickup areas tends to be greater. Basically this is not harmful as these areas are cathodic and non-corrosive.

There are situations where a simple bond, as discussed above, may not be fully effective. These conditions are described under the following two headings.

REVERSE CURRENT SWITCHES

Where there are multiple sources of DC current in a stray current source, such as multiple DC substations on a transit system, a problem arises if one or more of the substations is taken out of service during light load periods on the system. At an out-of-service substation, a simple drainage bond would serve as a path through which stray current could flow in the reverse direction through the bond onto the underground structure. This could greatly increase the amount of stray current picked up by the structure and further complicate the drainage problem at working substations.

To offset the above effect, reverse current switches can be used in drainage bond cables. These permit current to flow in the desired direction from the underground structure to the substation negative terminal; but when a stray current source system condition arises which tends to cause current to flow in the wrong direction through the drainage bond, the switch opens and prevents undesired stray current pickup by the underground structure. Some devices in this category utilize an actual switch operated

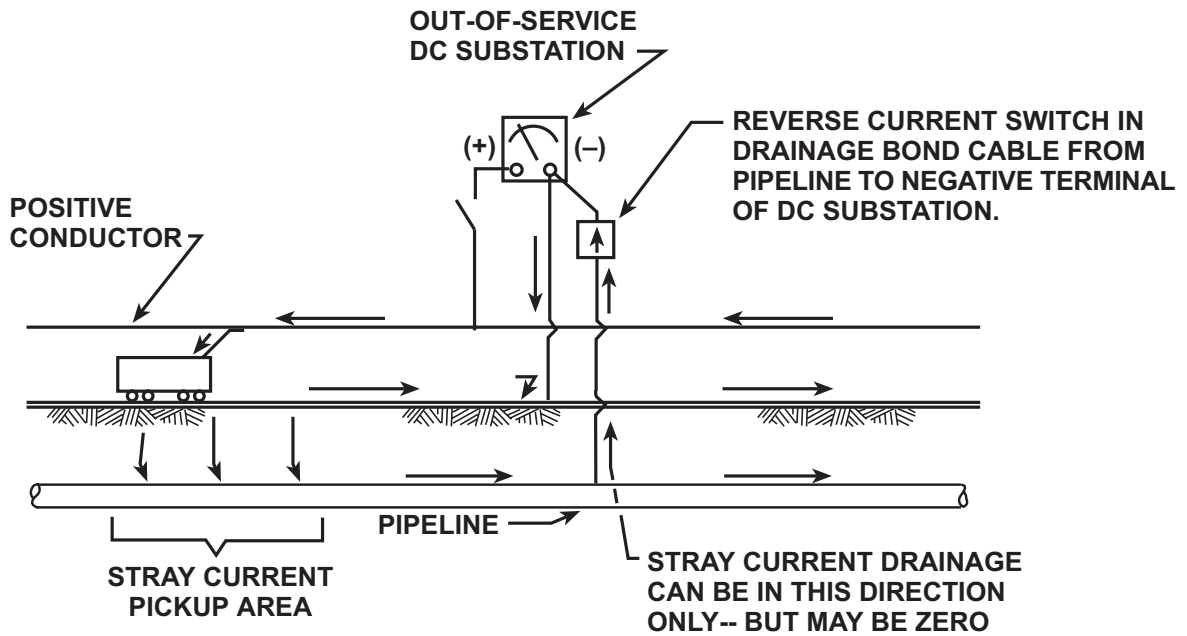

**APPLICATION OF REVERSE CURRENT SWITCH
IN STRAY CURRENT DRAINAGE BOND**

FIGURE 3-7

by reverse current sensing circuitry. In some applications, one way solid state diodes may be used.

The application of a reverse current switch to a typical instance is illustrated by Figure 3-7. Although, as shown on the figure, it would be possible for stray current discharge from the pipeline to flow in the indicated direction to the rails by way of the stray current drainage bond and the substation negative cable to rails, this would seldom occur. This would be because the rails would tend to be positive to the pipeline. With the substation out of service as shown, the more normal condition would be that the reverse current switch would be open and that the current in the circuit would be zero.

FORCED DRAINAGE BONDS

In some instances where stray current drainage is required to correct a corrosive condition on an underground structure, the distance from the drainage point on the underground structure to the negative terminal of the stray current source is so great that a simple drainage bond will have too much resistance to permit draining enough current to fully correct the corrosive exposure on the structure. Some means must be used to ensure that sufficient current is drained by compensating for the voltage drop in the drainage cable -- by Ohm's Law, this drop will be the stray current drained in amps multiplied by the total cable resistance in ohms.

The desired compensation can be attained by means of forced drainage. This means inserting a voltage source into the drainage bond circuit to force current to flow through the bond in at least the amount that would flow if the drainage bond had zero resistance. One means of accomplishing this is by inserting the output of an automatically controlled AC to DC rectifier power source into the drainage bond circuit. The automatic control circuitry in the unit will automatically control the applied compensating voltage to match the voltage drop in the drainage bond cable. The unit used will have to have a current carrying capacity to match the maximum stray current to be drained.

An added advantage is that the forced drainage unit may be adjusted to have a selected minimum current drainage. This means that if the DC substation to which the drainage bond is connected is out of service, there will be at least some current being drained back to the stray current source system.

The concept of the system described above is as illustrated by Figure 3-8. The details of such an installation are subject to forced drainage equipment used, method used for automatic control, etc.

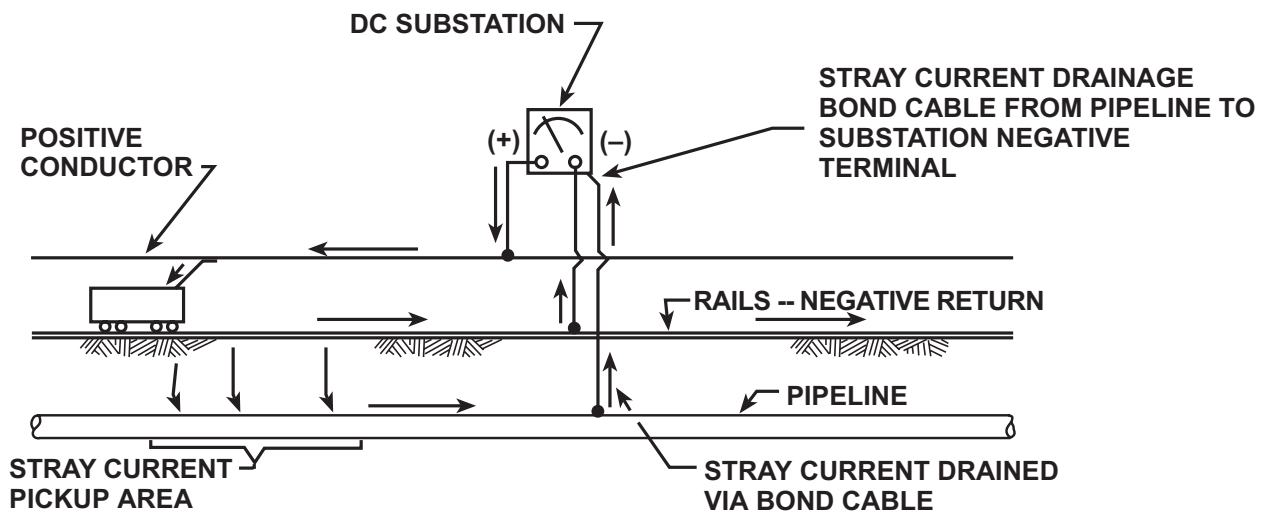

**APPLICATION OF STRAY CURRENT
DRAINAGE BOND**

FIGURE 3-6

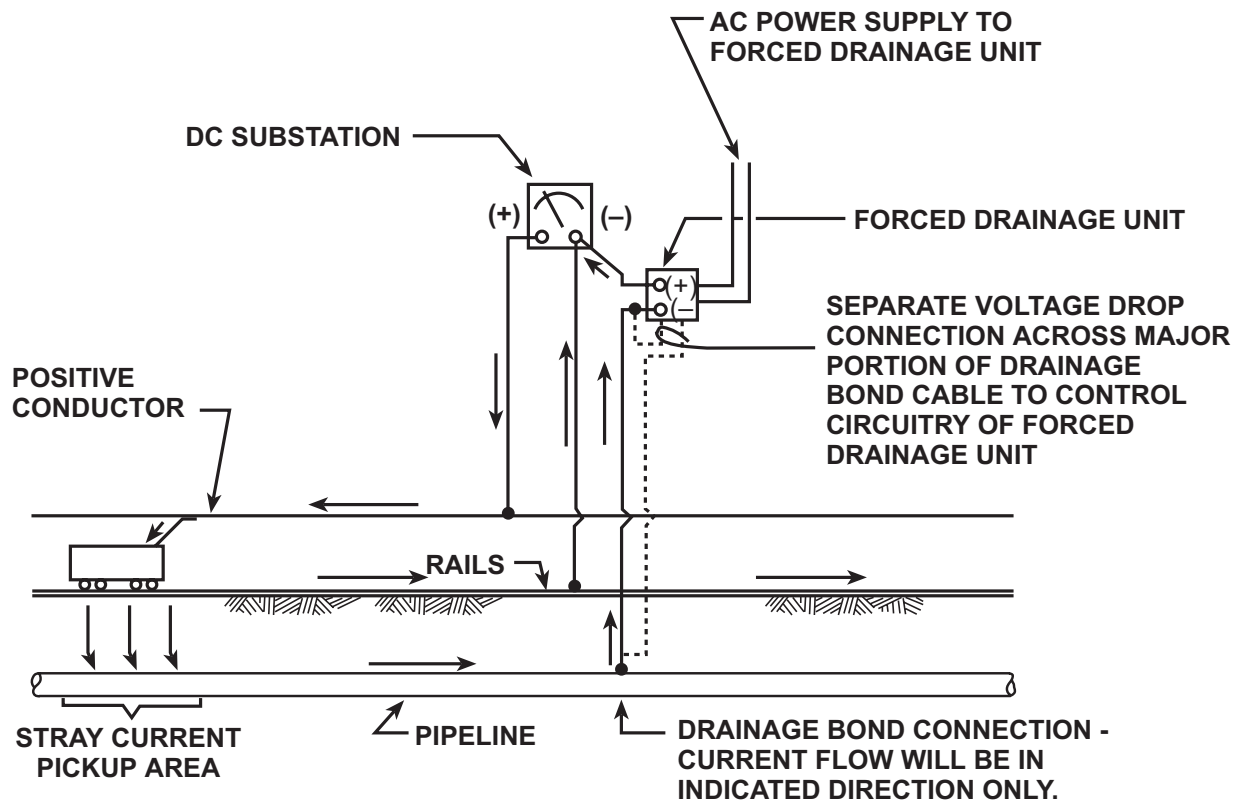

**APPLICATION OF FORCED DRAINAGE
STRAY CURRENT DRAINAGE BOND**

FIGURE 3-8

Chapter 4 – Introduction to Pipeline Coatings

INTRODUCTION

General

The pipeline coating is the most integral part of a cathodic protection system. Without the proper use of pipeline coatings, a cost-effective corrosion control program cannot be maintained. Chosen and applied properly, a pipeline coating can extend the design life of a piping system to well over 50 years. However, to be most effective, a pipeline coating must be used in conjunction with some form of cathodic protection. The better the coating, the less cathodic protection is required.

A pipeline coating is a barrier between the pipe and the electrolyte (soil or water) to keep all the corrodants away from the pipeline steel.

As you learned in Chapter 2, there are 4 components in the fundamental corrosion cell: anode, cathode, electrolyte and metallic path. There will be no corrosion if we eliminate any one of those components. A coating eliminates the electrolyte by isolating the pipe from it.

An effective pipeline coating system must possess excellent cohesive strength and adhesive bond strength to the pipe, be impervious to water penetration and provide good electrical (dielectric) resistance.

Adhesive strength is a measure of how well the coating is bonded to the pipe. Cohesive strength is a measure the ability of a coating film layer not to pull apart internally or stay bonded to its self.

Table 4-1 lists requirements for a “good” pipeline coating.

Laboratory Coating Tests

A laboratory test program with a battery of individual tests can determine the strengths and weaknesses of a coating system. A comparative laboratory analysis of cohesive and adhesive bond strengths of coatings can be determined through a standardized ASTM G-8 Salt-Crock Cathodic Disbondment Test. The test involves drilling an intentional coating defect or "holiday" into a coated pipe sample. The pipe sample is then connected to an electrical supply source consisting of a rectifier or anode at typically 1.5 volts for 30, 60 or 90 days in duration. The pipe sample is then submerged into a chamber filled with a 1% salt concentrate at a temperature of 73° F. At the end of the test period, the pipe samples are then removed from the chamber.

Table 4-1

General Requirements of a Pipeline Coating

- Ease of Application
- Good Adhesion to Pipe – Adhesive Strength
- Good Cohesive Strength
- Good Resistance to Damage
- Flexibility
- Resistance to Flow
- Water Resistance
- Good Electrical Resistance – Dielectric Strength
- Chemical and Physical Stability
- Resistance to Soil Bacteria
- Resistance to Marine Organisms
- Resistance to Cathodic Disbondment
- Resistance to Soil Stress

At the holiday area, coating is then peeled back to where there is still good adhesion and the area of disbondment is checked and recorded.

The dielectric resistance is the amount of voltage necessary to breakdown a given coating of specified coating thickness.

An ASTM G-9 Lab Test can determine the degree of water penetration into a pipeline coating given a dielectric constant. The test is often comparative in nature. If the dielectric properties of a coating are lost through water absorption, then coating effectiveness is severely weakened.

Electrical Inspection of Coatings

When checking for defects or holidays on the pipe coating surface, an electrical inspection tool or holiday detector should be utilized. By using a criterion of 125 volts per mil of coating thickness, one can pinpoint "holidays" or defects in the coating without dielectrically breaking down the coating. ASTM G-62 lists standard test procedures for setting the holiday detector when electrically inspecting for coating defects. If there is uncertainty in the field as to the proper setting, one may test simply by creating an intentional holiday in the coating. By running the holiday detector over the flawed coating area several times, one can determine through trial and error the proper setting. Normally this is done by listening to a "jeeping or beeping" sound and calibrating the length of spark given off by the holiday detector.

When using a holiday detector over periods of time, it is imperative to check the batteries at least twice a day or shift. It is also extremely important to keep the tail piece grounded to the earth in order to complete the circuit. When it is not possible to achieve a proper ground to the earth, one must ground the tail piece directly to the pipe.

Surface Preparation Standards

Pipeline coatings are applied either at a coating facility or in the field. In either case, proper surface preparation of the pipe is most critical to the successful performance of a coating. The Society for Protective Coatings (SSPC) has published standards listing various degrees of surface preparation. An SSPC SP6 - Commercial Blast Cleaning or an SSPC SP10 - Near-White Metal Blast Cleaning, are generally the preferred surface preparation processes required prior to the application of any coating in a coating facility or in the field.

The SSPC SP1 - Solvent Cleaning, SSPC SP2 - Hand Tool Cleaning and SSPC SP3 - Power Tool Cleaning methods of surface preparation are normally utilized in the field for repair coating. Whenever possible, however, an SSPC SP6 - Commercial Blast Cleaning or SSPC SP10 - Near- White Metal Blast Cleaning should always be used.

The surface preparation prior to the application of a plant or field applied coating must always meet the coating manufacturer's specifications. Different coatings require different levels of surface cleanliness and surface profile. Failure to meet all the manufacturer's requirements may result in premature coating failure.

PLANT APPLIED COATINGS

General

Several types of pipeline coating materials including fusion bonded epoxy, cross-head die extruded polyethylene and a variety of specialty-type coatings (two-part epoxy etc.) can be applied at the coating mill.

Fusion Bonded Epoxy

The fusion bonded epoxy process of coating pipe has gained widespread industry acceptance over the past forty years. Fusion bonded epoxy is normally applied with a thickness between 12 to 16 mils. The process involves the baking of powder epoxy onto a pipe surface heated between 450-500° F. An SSPC SP10 - Near-White Metal Blast Cleaning surface preparation is required prior to coating application. It is also critical in the surface preparation stage that all chlorides (salts) be removed with an acid bath application. The coating application is precise. Strict quality assurance standards need to be monitored (via inspection) throughout the coating process.

Extruded Polyethylene

Another plant applied coating that has been around for 40 plus years is the extruded polyethylene coating. Part of the surface preparation requires removal of moisture and contaminants from the pipe surface. An SSPC SP6 - Commercial Blast Cleaning is the standard surface preparation. The coating is comprised of an asphaltic-rubberized 10 mil mastic adhesive that is flowed onto the pipe surface. Through heating and cooling processes, an extruded polyethylene layer is then applied over the adhesive. The extruded polyethylene layer of normally 40 mil thickness is basically a mechanical barrier, which serves to lessen the amount of impact experienced during the shipping, handling, backfill, etc. Extruded polyethylene coating ranges from 40 to 60 mil thickness.

Coal-Tar Enamel and Asphalt Enamel

Coal-Tar Enamel and Asphalt Enamel coatings applied at the coating plant were used extensively in the past. However, due to environmental constraints, very few if any coating plants still apply hot coal-tar or enamel coatings. Normally, the Tar, Glass and Felt (TGF) or the Tar and Felt (TF) systems of the past were very popular. Most coal-tar and enamel coatings were comprised of 120 mils plus in thickness. As a lot of rehabilitation work still involves coal-tar and asphalt enamel coated pipe, it is imperative to use field-applied repair coatings that are generically compatible with coal-tar enamel and/or asphalt enamel.

Liquid Epoxy

Liquid epoxy applied at the coating plant is used as a primary coating as well as an Abrasion Resistant Overcoat (ARO) for bore pipe. The application method is by automated spray ring.

Other Plant Applied Coatings

Other plant applied coatings that can be considered specialty-type coatings include polyethylene, multi-layered polyethylene systems, epoxy polymer concrete, concrete-epoxy, polyurethane epoxy and dual-layer fusion bonded epoxy. Many of the specialty-type plant coatings listed above are becoming popular, because they fill an application need. Directional boring of pipeline has become a common application practice in the pipeline industry due to environmental concerns associated with wetlands and land-use. Most of the specialty coatings listed above possess excellent impact resistance qualities, which make them good candidates for that type of application, as well as providing extra backfill protection in rocky areas.

FIELD APPLIED COATINGS

General

Once the pipe is shipped to the job-site from the coating plant, the field coating of girth welds and repair of damaged areas becomes important. Various types of field applied coatings used for repair or girth welds during new pipeline installation include hot-applied coal-tar tape, cold-applied polyethylene tape, heat-shrink sleeves, fusion bonded field-applied epoxy and liquid epoxy coatings.

Note: It is always best to use the same or similar field coating for weld joints as the plant applied coating and a coating compatible with the plant applied coating for coating repairs.

Hot-Applied Tape

Hot-applied tape is generally a 60-80 mil bitumen tape product that consists of a blend of tar and high-temperature scrim. Hot-applied tape is used in conjunction with a primer.

The tape is heated with a weed burner or wide-mouth burning torch and applied to the pipe. On some types of hot-applied tape, a glossing over on the outside surface of the tape provides a degree of quality control to the application and is often recommended. Hot-applied tape should be spiral or “cigarette” wrapped tightly around the pipe utilizing a 50% overlap of product. The purpose of using a 50% overlap is to provide better dielectric strength to the application and a better resistance to soil-stress. Hot-applied tape is highly recommended as a coating repair for existing coal-tar enamel and asphaltic type coatings.

Hot applied bitumen tape possesses an excellent hot-melt bond strength to steel, excellent impact resistance, good dielectric strength and excellent chemical resistance. Hot-applied bitumen tape provides good conformability and performance when properly heated with tension. Since hot-applied bitumen tape is very forgiving in its application, a clean, dry surface preparation of SSPC SP1 - Solvent Cleaning, SSPC SP2 - Hand Tool Cleaning or SSPC SP3 - Power Tool Cleaning is all that is generally required for its application.

Cold-Applied Tape

Cold-applied polyethylene tape with an elastomeric synthetic-butyl adhesive is available in thickness ranging from 30 mils to upwards of 65 mils. Most cold-applied tape requires a liquid primer with its application. Some cold-applied tapes have an integrated primer and do not require a liquid primer if the temperature is over 40° F. However, a clean and dry surface preparation including SSPC SP1 - Solvent Cleaning, SSPC SP2 - Hand Tool Cleaning or SSPC SP3 - Power Tool Cleaning as minimal surface preparation becomes more critical than ever to the application process. When possible, using a primer with any tape or heat shrinkable system provides a superior application.

The major advantage of cold-applied tape is with its ease of application. The dielectric strength of cold-applied tape is excellent as is the pliability in cold weather. Cold-applied tapes should be used where direct burial of pipe is involved. In the case of plowing-in or boring applications of pipeline, other field-applied coating materials

should be considered. Rock shield and/or select backfill should always be used as an option when harsher than normal soil conditions exist.

Most of the newer generation of cold-applied tapes on the market are made with geotextile or mesh-backed film backings that are more abrasion resistant than traditional polyethylene backings. Some of the newer cold-applied tape film backings also possess UV (ultra-violet) resistance in their formulation. This now makes it possible to use cold-applied tape for both above and below-ground applications. In addition, petrolatum/wax type tapes used in conjunction with UV resistant outer wraps are very popular and perform well for atmospheric pipe span applications.

Heat-Shrink Sleeves

The heat-shrink sleeve is another method of coating girth welds. Heat-shrink sleeves are available in either tubular or split sleeve form. The heat-shrink sleeve is normally 70-90 mils in thickness and consists of cross-linked radiated polyethylene. On the surface of the sleeve, there are built-in design features that indicate to the user when enough heat has been applied to the shrink-sleeve.

The tubular shrink-sleeve application requires that the user remove a release paper and slide the sleeve over the girth weld. The sleeves must be in position near the place of application prior to welding of the pipe. The application of heat should be applied from the middle out towards the edges in a horizontal and/or vertical fashion.

With the split shrink-sleeve application, a filler material/sealant should be used over the longitudinal seams and girth weld beads. A pre-cut shrink-sleeve of correct length with a width of 12" or 18" is wrapped around the girth weld area. Heat then is applied with a torch proceeding from the weld seam outward towards the edge of the sleeve. Upon completion of the heating process, a closure strip is often applied over the end of the lap to ensure that a 3" to 4" overlap of material is maintained on top. Split shrink-sleeves are economical when used on larger diameter pipe. Tubular sleeves are more practical to apply on smaller diameter pipe.

The heat-shrink sleeve possesses good impact resistance and dielectric strength. Heat-shrink sleeves have generally had a good history on medium to smaller diameter pipe sizes and remain very popular due to their ease of application in the field. However, application and surface preparation is critical.

When possible, using a primer with any tape or heat shrinkable system provides a superior application.

Fusion Bonded Epoxy

The fusion bonded epoxy (FBE) type of field application for girth welds can be used on any diameter pipe coated with FBE at the coating plant. It becomes more economical when large diameter pipe is being coated and/or where substantial footage is involved. The process is similar to the plant coating application, whereby the pipe must be cleaned per SSPC SP1 – Solvent Cleaning then abrasive blasted to an SSPC SP10 - Near-White Metal Blast Cleaning. An induction heater heats the pipe to 450° F. FBE epoxy powder is then flocked/sprayed onto the weld surface using a wheel applicator (or manually applied) that transverses around the circumference of the pipe. Typically, several passes of the wheel are required to achieve the specified coating thickness.

By using the fusion bonded epoxy process in the field, one can achieve a plant-type coating that is superior in terms of application. Tight standards regarding surface preparation (SP 10) and application temperature (450° F range) must constantly be maintained. A certified coatings technician is usually hired to monitor the coating operation.

Liquid Epoxy

Liquid epoxy includes epoxy urethane, epoxy novolac and ceramic epoxy.

Liquid epoxy in its various forms is being used extensively in the field for coating repair, mainline application to girth welds, coating of uncoated pipe sections and as a field applied Abrasion Resistant Overcoat (ARO) for bore pipe.

Liquid epoxy (high performance) coatings are used due to their high dielectric strength, resistance to soil stress, high abrasion resistance and ease of application. Liquid epoxies may also be used as an effective internal pipe lining for flow enhancement and internal corrosion. Due to its abrasion resistance, liquid epoxies will stand up to pigging operations on internally lined pipes.

Field surface preparation for liquid epoxies is normally SSPC SP10 - Near- White Metal Blast Cleaning with a sharp angular profile at 2 to 5 mils. The blast media is normally coal slag based or garnet. As always, verify the surface preparation requirements with coating manufacturer. Abrasive blasting may be accomplished with hand blasting or an automated blast ring.

Care must be taken to insure the air supply for blasting and sprayable cartridge application is clean, dry and oil free. Aftercoolers may be used to condition the air.

Field application is accomplished via hand (brush, pad, or roller application), sprayable cartridge, plural component hand spray and automated spray ring. Normal film thickness is between 20 and 50 mils for normal corrosion protection applications. A thicker film is required for bore pipe applications. The required film thickness must be verified with the coating manufacturer.

Maintenance Coatings

Until now, the discussion has centered on pipeline coatings used for new construction. However, several of the field coatings discussed above i.e., hot-applied coal-tar tapes, cold-applied polymer tapes and liquid epoxies are also used for maintenance applications. In addition, liquid mastics, sealants, hot-applied waxes, cold-applied petrolatum/waxes, liquid coal-tar epoxies, high-temperature tapes and flange-fillers are used for numerous maintenance coating applications. All these coatings work well within their limits and need to be verified to confirm their compatibility with the parent or plant pipeline coatings.

As a result of in-line inspections (ILI), "hot-spot" or "bell-hole" reconditioning and recoating frequently requires the use of heavy-duty maintenance coatings. Many of these coatings are selected based on past experience, cost and their compatibility with existing coatings found on the pipe. Heavy-duty reconditioning coating materials usually include hot-applied coal-tar tape, cold-applied mesh-backed tape, hot-applied wax, liquid epoxy and liquid coal-tar epoxy. The coating selection again is based on field conditions and compatibility with the parent coating of the pipeline.

Coating of Exposed Pipelines

Another reconditioning application involves exposed piping installed on bridges and engineered spans. In these instances, atmospheric corrosion has corroded the pipe and/or disturbed the original coating through ultra-violet (UV) degradation. A UV resistant cold-applied tape coating or a UV resistant cold-applied petrolatum/wax tape coating works well in those instances. Ordinary paint could be used as a short-term solution, but requires considerable ongoing maintenance.

The use of urethane/epoxy coating systems has become very popular for these applications over the past few years. A base coat of urethane/epoxy provides the hardness (impact resistance) and flexibility. Some urethane/epoxy coating systems also provide UV protection. Some urethane/epoxy coating systems require an acrylic aliphatic urethane top coat to provide UV protection. A general roughing or brush-blast of the epoxy must always occur prior to the application of any overcoats.

Risers, valve stems and other below ground to above ground transition areas are another application that require reconditioning. Some of the most severe corrosion occurs at the pipe-soil and air interface area of a riser. Several maintenance coatings that are used for riser applications include UV resistant cold-applied tapes, UV resistant cold-applied petrolatum/wax tapes, UV resistant liquid epoxies and hot-applied tapes (whitewashed). The coating of choice first must be durable and secondly provide good resistance to the atmosphere. Some of these coatings require additional mechanical protection and an overcoat of a good polyurethane or paint system to provide adequate UV protection.

Bolted couplings and flanges, valve pits and fittings associated with the maintenance of piping would be another type of field coating application. In these instances, ease of application with a "field friendly" coating material are of paramount importance. A liquid mastic or a petrolatum/wax type of application have been used frequently in these situations. In wet conditions or where pipe constantly sweats, petrolatum/wax tape coatings work very well.

High Temperature Coatings

Another area where existing coatings often become deteriorated and sometimes fail is on high-temperature discharge header type applications. These areas are found at natural gas compressor sites where pipe runs out from the compressors to the after-coolers. In the past, plant applied coatings were used because little else was available at that time. Coal-tar epoxy, high temperature amine epoxy or high temperature cold-applied tape with primer or high temperature cold-applied petrolatum/wax tape are currently being used to recondition those areas.

Coating of Flanges and Flange Bolts

As part of an atmospheric inspection program, operators of gas meter, regulator, and compressor sites often check flanges and bolts within flanges. Because of the high cost of bolts coupled with the safety factor, there is a willingness on the part of station supervisors to deal with the problem from a maintenance mode. There are numerous ways to coat existing flange bolts and arrest the corrosion process. One method involves pumping flange-filler with a caulking gun into the flange until the entire area is filled. This stops any corrosion processes from continuing. The flange-filler, however, must not shrink, must provide dielectric resistance and must be easily removable upon re-entry into the flange.

Another method involves flood coating the flange with hot-applied wax coating. Many other methods have been tried over the years with limited success.

After filling the flange annular space a flange band or flange tape needs to be applied to keep the flange filler material from leaking out of the flange.

CONCLUSION

In conclusion, there are many excellent plant-applied and field-applied pipeline coatings on the market today. However, not every coating is good for all applications. Good surface preparation and overall cleanliness of the pipe will create a better environment for coating performance.

REFERENCES

1. Gunther, Carl - Washington Gas Light Company, "ASTM Series of Coating Tests," pp. 21, 22 from the Proceedings of The 1993 Appalachian Underground Corrosion Short Course.
2. The Society for Protective Coatings, SSPC Volume 2, "Systems and Specifications", sspc.org.

Chapter 5 - Potential Measurements

INTRODUCTION

The making of accurate potential measurements is critical to many areas of corrosion control work on underground structures. If such measurements are not made correctly (or if unsuitable instrumentation is used) erroneous conclusions can be reached as to the need for corrosion control. Also, when potential measurements are used for evaluating the effects of a cathodic protection system, inaccurate potential readings can lead to entirely incorrect conclusions regarding the performance of that system.

Material to be covered in this chapter includes the following:

- An overview of instrumentation requirements
- Reference electrodes used in certain potential measurements
- Types of potential measurements
- Potential measurement techniques
- Polarization effects
- Criteria for cathodic protection
- Monitoring cathodic protection systems

INSTRUMENTATION

Voltmeters

Voltmeters can be classified into analog and digital types. Voltmeters used for measuring potentials between a structure and a reference electrode contacting earth should be of the high resistance type to avoid serious error.

An analog voltmeter uses a moving needle or pointer that takes a position on a calibrated scale from which the electrical quantity being measured can be read. The movement of the pointer is known as a "D'arsonval movement." The operating principle is based upon electrical current passing through a coil to form an electromagnetic field. The intensity of the moving coil magnetic field is proportional to the amount of current passing through the coil. Even though a voltmeter measures electrical potentials, it is still a current operated device.

A digital voltmeter is entirely electronic and uses a digital readout module to display the digital characters as the applied electrical signal changes. There is no actual physical movement. The input resistance of the digital voltmeters is typically very high (ten megohms or higher). The high input resistance means that the current taken from the external circuit will be very small. The advantage of this is that there will be very little voltage drop through the external circuit.

Effect of Voltmeter Resistance on Potential Being Measured

In corrosion control work on underground structures, the majority of potential measurements are taken between the structure and a reference electrode contacting the surface of the earth. The ohmic resistance between the structure and the connections to the voltmeter can be very high - in some cases thousands of ohms. This resistance is called the external resistance, R_e .

To obtain accurate potential measurements, the internal impedance of the meter (R_i), referred to as the meter impedance, must be very high with respect to R_e . Failure to understand and observe this fact will lead to seriously inaccurate field data.

The importance of taking accurate potential data cannot be overemphasized. These data are not only required for compliance reports, but are also essential to determine the effectiveness of cathodic protection.

Figure 5-1 illustrates a digital meter of the type commonly used for structure-to-soil potential measurements. The meter requires a very small current, usually only a few microamperes, to operate the meter display. Placing even a low voltage across the meter terminals would instantly blow out the display. Consequently, a very high impedance (or resistance [R_i]) is placed in series with the display mechanism (Figure 5-1). The accuracy of the meter depends on the ratio of the meter impedance to the external resistance.

The external resistance (R_e) consists of the structure-to-earth resistance, the resistance of the earth path, the resistance of the electrode to earth, the resistance within the electrode, the resistance of lead wire connections and the resistance of the lead wires between the voltmeter and the structure and between the voltmeter and the electrode (Figure 5-1). In high resistivity soils or under dry surface conditions, the resistance from the structure to the electrode terminal may be several thousand ohms. In many cases, a reel of perhaps a thousand feet of small diameter wire is used to connect the electrode to the voltmeter. The resistance of this wire can amount to 100 ohms or more.

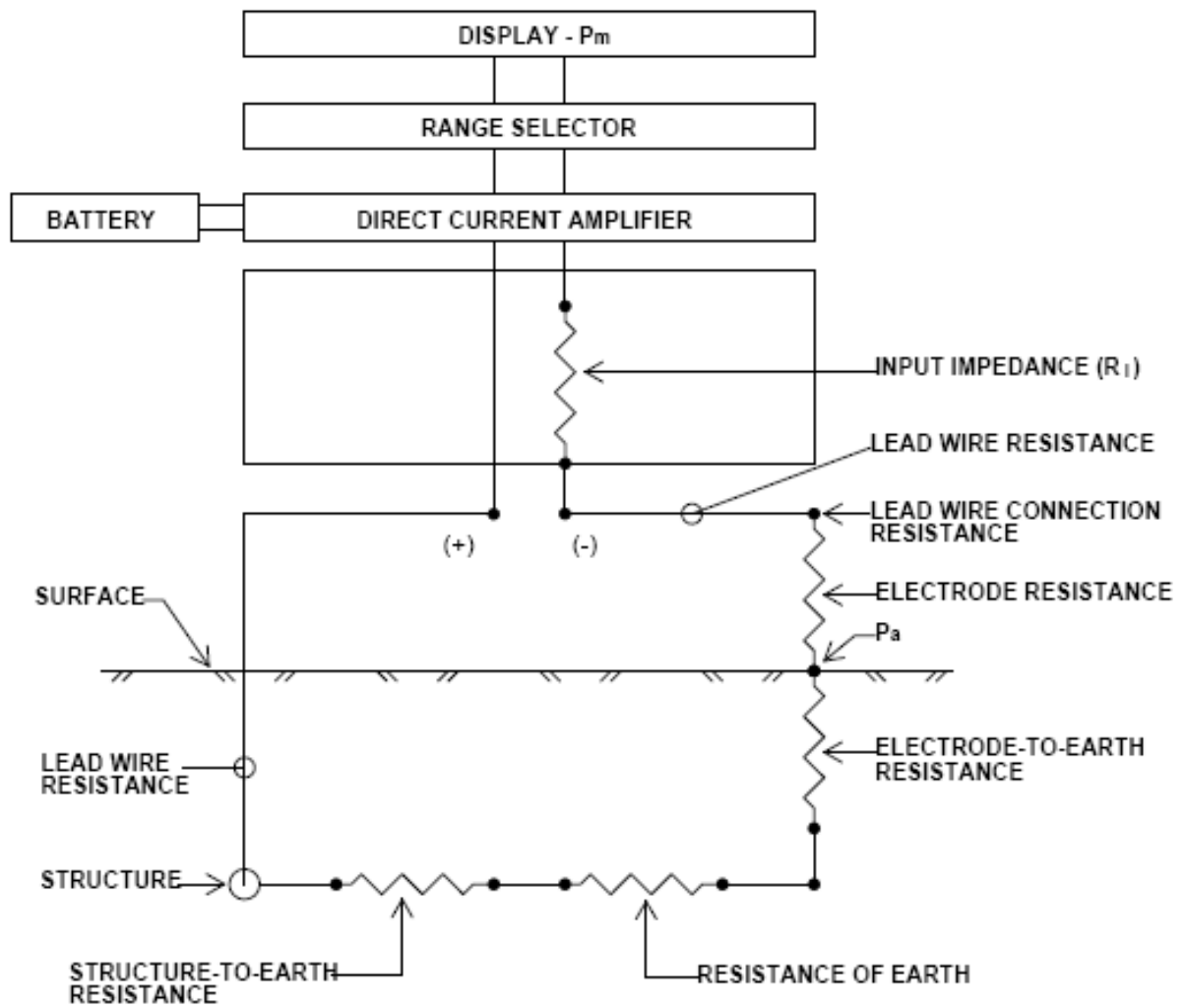

DIGITAL VOLTMETER OPERATION SHOWING COMPONENTS OF EXTERNAL RESISTANCE (R_e)

FIGURE 5-1

The current required to operate the meter display creates a small voltage (IR) drop in the meter impedance. The display is calibrated to allow for this IR drop, so the display shows the actual potential that appears across the meter terminals.

The operating current also creates an IR drop through the external resistance (R_e). This IR drop is directly proportional to both the magnitude of the current and to R_e and affects the potential that appears across the meter terminals.

From Ohm's Law, $I = E/R$, we see that the higher the input impedance of the meter (R_i), the lower the display operating current. The lower the operating current, the lower the IR drop through R_e , and thus the more accurate the potential that appears across the voltmeter terminals.

Modern digital voltmeters, such as those used today for potential measurements, have a very high meter impedance (R_i), typically 10 megohms or more. This impedance is the same for all the voltage ranges on the instrument. When these instruments are used, the external resistance seldom causes a problem, as we shall discuss next.

The measured potential, that shown on the meter display (P_m), is directly proportional to the ratio of R_i to the total circuit resistance (R_t).

Equation 1 shows the calculation of total circuit resistance (R_t):

$$\begin{aligned} R_t &= \text{Meter Impedance} + \text{External Resistance} \\ &= R_i + R_e \end{aligned} \tag{1}$$

The ratio is shown by Equation 2:

$$\text{Ratio} = R_i / R_t \tag{2}$$

The measured potential (P_m) then equals the ratio times the actual potential (that at the electrode location [P_a]), as shown in Equation 3:

$$P_m = P_a \times \text{Ratio} \tag{3}$$

The higher the ratio, the more accurate P_m is.

The actual potential (P_a) mentioned in this discussion is the actual potential of the

structure that appears at the location of the electrode. P_a thus includes the IR drop caused by the cathodic protection current. P_a is therefore not the actual potential at the surface of the structure.

Modern digital voltmeters, such as those used today for potential measurements, have a very high meter impedance (R_i), typically 10 megohms or more. Attempting to take structure to soil potentials with an incorrect instrument can yield seriously erroneous measurements as the following examples show.

Let us suppose that R_e in a certain situation is 2500 ohms and that the actual potential (E_a) at the electrode location is -0.950 V. Let us further suppose that a corrosion technician attempts to take potentials with an inexpensive little meter with a meter impedance (R_i) = 1000 ohms. Now, from Equation 1:

$$R_t = (R_i + R_e) = 1000 + 2500 = 3500 \text{ ohms}$$

From Equation 2, we see that

$$\text{Ratio} = R_i / R_t = 1000/3500 = 0.286$$

We find the measured potential (P_m) from Equation 3 is:

$$P_m = P_a \times \text{Ratio} = -0.950 \text{ V} \times 0.286 = -0.272 \text{ V}$$

The measured potential is only 28.6% of the actual potential, a serious error.

Now let us see what happens when the technician uses a good digital meter with a meter impedance (R_i) of 10 Megohms (10,000,000 ohms).

From Equation 1:

$$\begin{aligned} R_t &= (R_i + R_e) = 10,000,000 + 2500 \\ &= 10,002,500 \end{aligned}$$

From Equation 2, we see that

$$\text{Ratio} = R_i / R_t$$

$$= 10,000,000 / 10,002,500 = 0.999$$

We find the measured potential (P_m) from Equation 3 is:

$$P_m = P_a \times \text{Ratio} = -0.950 \text{ V} \times 0.999 = -0.949 \text{ V}$$

The measured potential now is 99.9% of the actual potential, a negligible difference.

The purpose of this discussion is to show how important it is to use the correct voltmeter when making potential measurements. As mentioned earlier, accurate potential measurements are absolutely essential to provide the data required for compliance reports and to establish the effectiveness of cathodic protection.

Care and Storage of Instruments

Corrosion test equipment has to be treated with care. For reliability, it must be treated as delicate equipment during transportation and field use. Instruments must be kept clean and maintained in good working order. When instruments are returned to storage between field usages, they should be completely checked and calibrated (where necessary) for the next time needed. Any batteries should be removed to prevent the possibility of battery leakage with internal corrosive damage to the instrument.

REFERENCE ELECTRODES

In corrosion control testing of underground metallic structures, we frequently need to measure the potential between the structure and its electrolyte (soil or water). Unfortunately, this is not a measurement that can be made directly. We can however measure the potential difference between the structure and some other metal that is also in contact with the electrolyte. It is not as simple as inserting the end of the test wire into the ground or connecting it to a steel or copper rod in the electrolyte even though a reading is obtained. These readings are useless as they are not repeatable. Further, they will not be applicable to some of the criteria for protection. This problem was solved with the development of reference electrodes which are used to contact the electrolyte. A reference electrode is simply a device which is used to contact the electrolyte and to which one terminal of the voltmeter is connected. To be suitable, a reference electrode must have a relatively constant "half-cell potential". A reference electrode is one half of a corrosion cell consisting of a metal in a solution of its metal ions. The "half-cell" potential is constant if the concentration of metal ions in the solution around the metal remains constant.

The most common reference electrode used in cathodic protection testing is the saturated copper/copper sulfate reference electrode. This electrode is sometimes referred to as "a half-cell", "copper sulfate", "Cu/CuSO₄" or "CSE". The components of a typical saturated copper/copper sulfate reference electrode are shown in Figure 5-2.

As previously stated, in order to for a reference electrode to be suitable, it must have a constant half-cell potential. In order to have a constant half-cell potential, the concentration of metal ions in the solution around the metal must remain constant. With the saturated copper/copper sulfate reference electrode this is achieved by having a constant concentration of copper ions (saturated) in the solution around the copper rod.

The saturated copper/copper sulfate reference electrode is simple and reasonably rugged but there are precautions that must be observed for accurate results. These are:

1. The copper rod must be cleaned so that it is bright and shiny and free of contaminants. The copper rod should be cleaned by using a new, unused, non-metallic scouring pad or sandpaper. Green scouring pads are preferred. When green scouring pads are unavailable, sandpaper can be used. Oxide type sandpaper cannot be used since it will introduce unwanted metals into the surface of the copper rod. Do not touch the copper rod with bare fingers after it has been cleaned.
2. The copper sulfate solution must be free of contaminants. The solution should be made with deionized or distilled water, or with a gel made specifically for use in copper/copper sulfate reference electrodes. Only high purity copper sulfate should be used.
3. The tube must contain a saturated solution of copper sulfate. In order to ensure the solution is saturated, there must be copper sulfate crystals visible in the solution.
4. The porous plug must be moist. The porous plug provides electrical contact between the reference electrode and earth. If the plug is dry, the measured potentials may be inaccurate. When new electrodes are prepared, the plugs should be moistened for at least 24 hours prior to use. When the electrode is not in use, the porous plug should be covered with a protective cap to prevent it from drying out.
5. The accuracy of reference electrodes should be checked periodically. A new reference electrode can be prepared and used as a standard. This "standard" electrode should not be used in the field so that it remains uncontaminated. The field

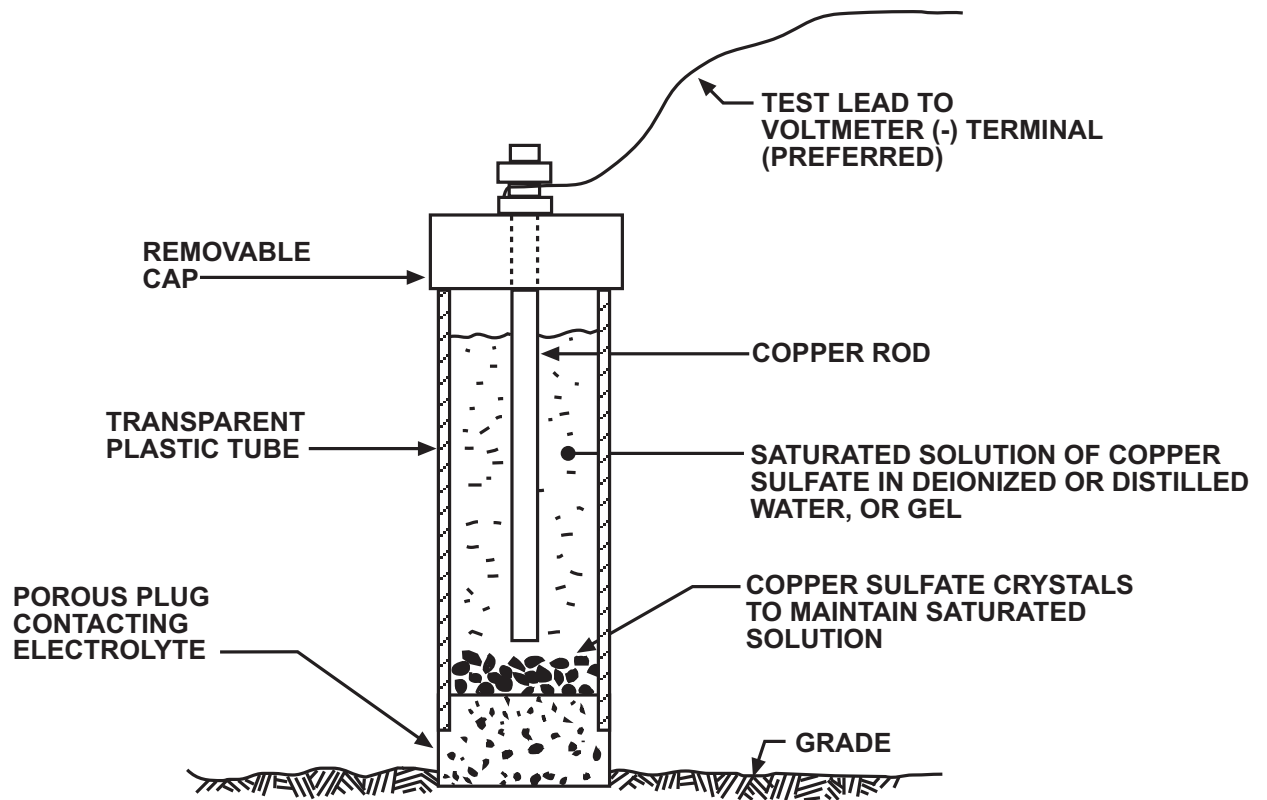

**TYPICAL SATURATED COPPER/COPPER SULFATE
REFERENCE ELECTRODE**

FIGURE 5-2

electrodes can be checked against the standard electrode by placing the two electrodes in a glass or plastic container containing a dilute solution of copper sulfate and measuring the voltage difference between them. If the voltage difference between the standard electrode and field electrode is more than 10 millivolts, the field electrode should be refurbished. Some companies may require the voltage difference to be some value less than 10 millivolts.

There are two characteristics of saturated copper/copper sulfate reference electrodes when in use that should be known. The first of these is temperature effect. The half-cell potential although basically constant in other respects is subject to some variation with change in the temperature of the copper sulfate solution above or below a median point of 77° F. This potential change is in the order of -0.5 millivolt per degree as per the following formula:

$$E_{CSE}^* = E_{CSE} - 0.5 \text{ mv}/^{\circ}\text{F} (T - 77^{\circ}\text{F})$$

Where:

E_{CSE}^* = corrected potential

E_{CSE} = potential read

T = temperature in °F of copper sulfate solution

If a potential reading measured to a saturated copper/copper sulfate reference electrode is 0.80 volt, it would, for example, be:

1. At an electrode temperature of 87° F:

$$0.80\text{V} - (0.5 \text{ mV} \times 10^{\circ} \text{ temperature rise above } 77^{\circ})$$

$$= 0.800\text{V} - 0.005\text{V} = 0.795 \text{ Volt}$$

2. At an electrode temperature of 57° F:

$$0.80\text{V} + (0.5 \text{ MV} \times 20^{\circ} \text{ temperature drop below } 77^{\circ})$$

$$= 0.800\text{V} + 0.010\text{V} = 0.810 \text{ Volt}$$

Knowledge of this effect could be useful when making critical measurements.

The other characteristic is a photoelectric effect caused by sun striking the copper sulfate electrode. This appears to be a factor when the copper rod of the electrode is not sufficiently clean. This can be checked by shading the electrode to see if there is any change in the voltmeter reading. If there is a change, keep the electrode shaded.

Another type of reference electrode that the underground structure corrosion worker should be aware of is the saturated silver/silver chloride electrode for use in sea water. This would be used, for example, when working on off-shore pipelines and drilling platforms.

The need arises for this because of the possibility of contamination, by sea water, of the copper sulfate solution in the saturated copper/copper sulfate reference electrode. The saturated silver/silver chloride reference electrode does not contain a liquid solution to be contaminated. It comprises a core of silver gauze on which is deposited a film of silver chloride with the assembly enclosed in a protective sleeve which allows free entry of sea water when the electrode is in use.

The half-cell potential of the saturated silver/silver chloride reference electrode in 25 ohm-cm seawater is 0.05 volts less than that of the saturated copper/copper sulfate electrode. Accordingly, in order to convert saturated silver/silver chloride reference electrode readings to saturated copper/copper sulfate reference electrode readings, add -0.05 volt. For example:

-0.84 volt to silver chloride in seawater = -0.89 volt to copper sulfate

Electrode-to-earth Resistance

It should be noted that the contact resistance between a saturated copper/copper sulfate reference electrode and earth is the usual cause of high external resistance in potential measurements and is what necessitates the use of high resistance analog voltmeters or digital voltmeters. This is because the contact surface between the electrode porous plug and earth is so small. The actual amount of this resistance is a function of the resistivity of the soil contacted by the electrode tip. High resistivity soils give high electrode-to-earth resistances.

When placing the reference electrode to take a reading, it helps to scrape away any dry surface soil to expose a moist surface. If soil conditions are so dry that this is not

effective, wetting the surface with water can be helpful in reducing the contact resistance.

Also, when placing the reference electrode, make sure that there is no contact between exposed metal (at the test lead connection end of the reference electrode) and grass, weeds, or anything else foreign to the measurement circuit. This is necessary to avoid possible effect on the potential being measured. Likewise, it is essential that all test leads used in setting up the potential measurement circuit be well insulated and that the insulation be free of cuts, breaks, or scrapes that could allow possible contact to earth or vegetation. If there should be leakage paths to earth at any such points, the potential being measured could be affected making recorded values subject to error of an unknown amount. This is particularly important when working under wet conditions.

STRUCTURE-TO-EARTH POTENTIAL MEASUREMENTS

With an understanding of instrumentation requirements and the use of reference electrodes, consideration can be given to their use in making various types of potential measurements. Structure-to-earth measurements normally will be the most common type made in underground structure corrosion control work.

The potential measurement commonly called the pipe-to-soil potential should be made using a high input resistance voltmeter (typically 10 megohm or higher) connected between the pipe and a reference electrode located on the earth as close as is practicable to the pipeline as illustrated in Figure 5-3.

This potential difference measurement not only includes the pipe polarized potential (E_p) within the influence of the reference electrode, but also the voltage drop in the soil (IR_{soil}) between the reference and the pipe and the voltage drop in the pipe (IR_{pipe}) between the point of contact to the pipe and the point of measurement. With the cathodic protection current 'ON' (applied), the voltmeter measures the total potential difference without being able to distinguish the pipe polarized potential (E_p) and therefore:

$$V_m = E_p + IR_{soil} + IR_{pipe}$$

In the example shown the IR drops are additive since their polarity is same as E_p and the voltmeter will indicate that the pipe is more electronegative than the actual polarized potential (E_p). If the cathodic protection current in the pipe is in the opposite direction then the pipe IR drop would subtract from the pipe-to-soil potential measurement. It is

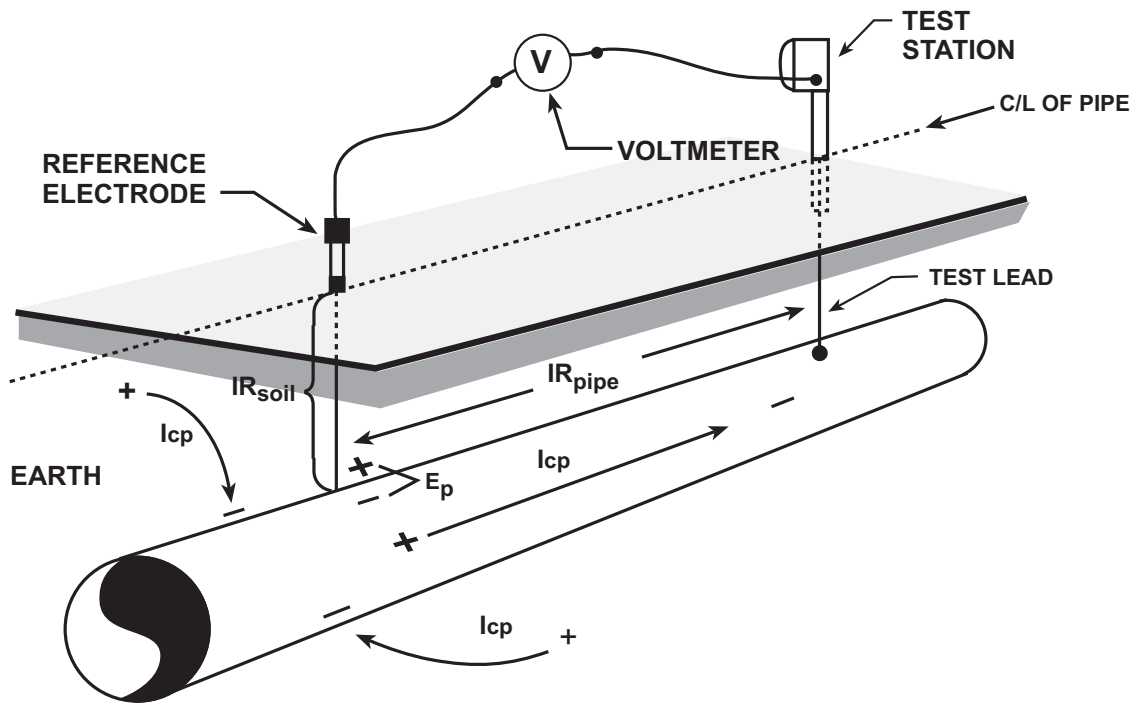

PIPE-TO-SOIL POTENTIAL MEASUREMENT

FIGURE 5-3

these IR drop voltages which must be taken into account for valid comparison to the criteria.

Figure 5-4 illustrates common potential measurements as made on an underground pipeline. The figure shows, with solid lines, potential measurement to a "close" reference electrode directly above the pipe. This is the more common measurement as the reference electrode is, normally, in the most neutral area with minimum effect on the potential caused by voltage drops in the earth resulting from direct current flowing to or from the pipe.

The dashed line showing a test lead extension to a "remote" reference electrode location. This may be used on bare pipelines or complex underground systems in checking cathodic protection coverage to verify that "long line" corrosion cells have been neutralized. Long line cells being anodic and cathodic areas separated by some distance as opposed to those which may be a few feet or a few inches apart.

As a rule of thumb, the area "seen" from a reference electrode on a bare structure is that subtended by an angle of roughly 120° (see Figure 5-5).

For this reason, the close reference electrode "sees" only a relatively small portion of the bare structure as opposed to the remote reference electrode location.

By "remote" reference electrode is meant a reference electrode location which is electrically remote from the structure. There is no fixed distance figure for this. It can be determined in the field (for a bare structure) by first taking and recording a potential reading between the structure and a reference electrode placed, for example, 50 feet from the structure. The reference electrode is then moved further away from the structure by approximately 50-foot increments in a direction perpendicular to the structure. The structure-to-reference electrode potential is measured and recorded at each location until there is no significant change in the reading from one point to the next. This is an indication that electrically remote earth has been reached. For large bare pipelines, for example, this distance could be (but not necessarily so) several hundred feet. The reason for variation is variation in earth resistivity and its geological structure - both affecting the distance from the bare structure needed to encompass essentially all of the structure-to-earth resistance.

In contrast to bare structures, the structure-to-earth resistance for well coated structures includes the resistance across the coating as the major element of the total structure-to-earth resistance. For this reason, a "close" reference electrode location at

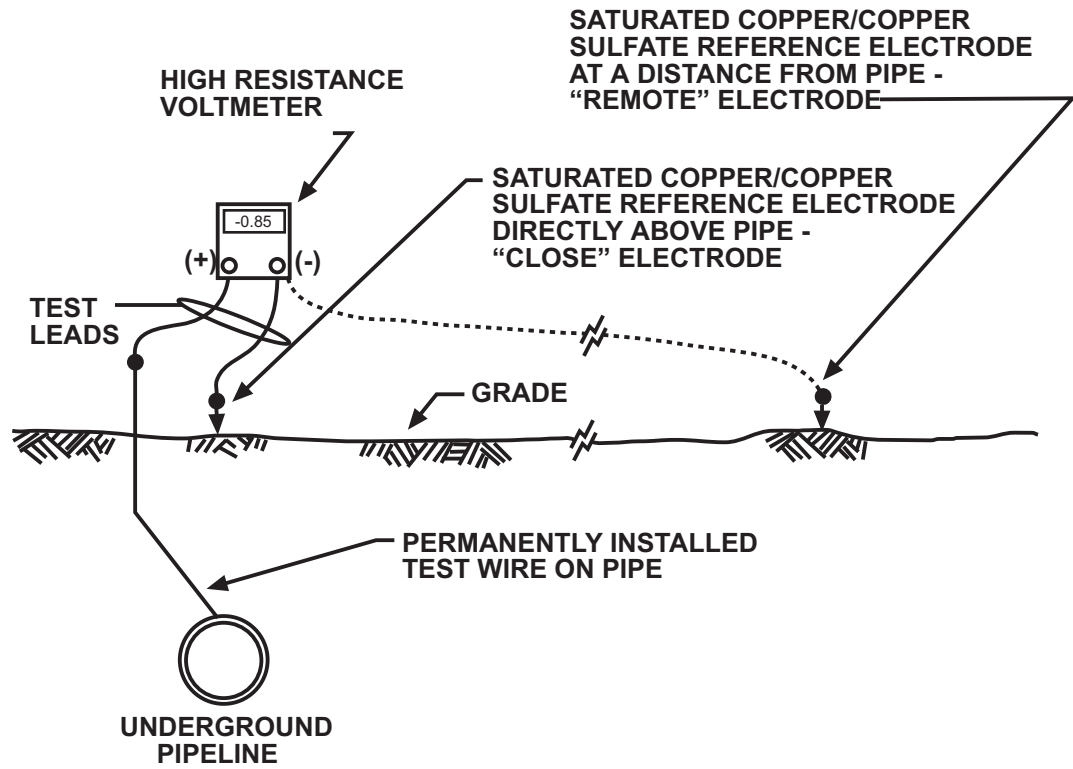

**STRUCTURE-TO-EARTH
POTENTIAL MEASUREMENT**

FIGURE 5-4

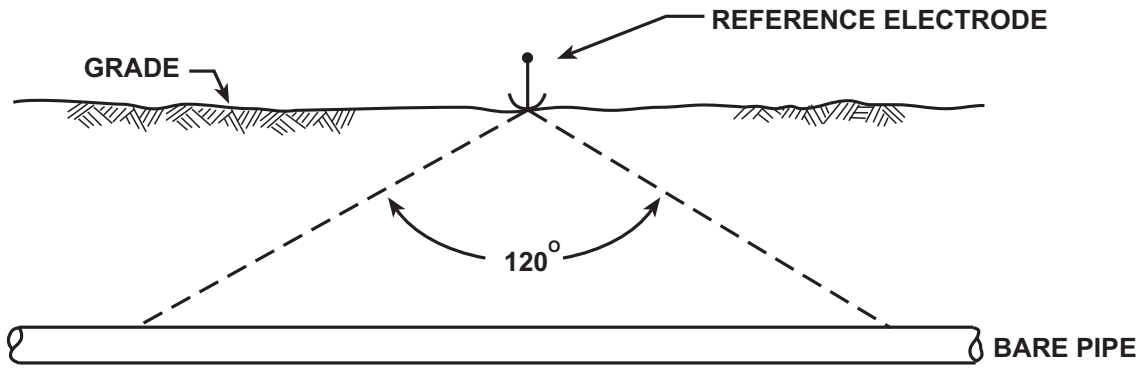

**AREA "SEEN" BY REFERENCE ELECTRODE
ON A BARE STRUCTURE**

FIGURE 5-5

a coated structure is, for practical purposes, in the equivalent of electrically remote earth.

On large bare structures, once the reference electrode has been placed in electrically remote earth, the potential measured between the structure and the reference electrode reflects the average of widely spaced anodic and cathodic areas from long-line corrosion cells. Experience has indicated that, on steel underground structures for example, when a potential of -0.85 volts, structure-to-saturated copper/copper sulfate reference electrode, is observed, the widely spaced (long-line) corrosion cells have been stifled. This does not necessarily mean that small local cells within the larger cells are likewise stifled. They still can be active in local areas. For this reason, readings to remote reference electrode on bare structures, although useful for determining the stifling of large longline cells (which may well be the major source of corrosion), cannot be used as an indication of when complete protection is attained for all surfaces of the underground bare structure.

On Figure 5-4, it will be noted that the (-) terminal of the voltmeter is connected to the reference electrode with the (+) terminal connected to the pipe. This is the preferred method. With this polarity, pipe-to-soil potentials are normally negative values (such as -0.750 volts).

There can be situations in strong stray current exposure areas where the structure can be positive with respect to the reference electrode (reversed polarity from that shown on Figure 5-4). Readings are then recorded accordingly (such as +0.425 volts). This means that the structure is very strongly anodic and subject to possible heavy corrosion damage.

The age and condition of an underground structure such as a pipeline can have an appreciable effect on the potentials measured to a close saturated copper/copper sulfate reference electrode. An old, bare structure that is not cathodically protected may have potentials that are generally low in value (such as in the -0.1 to -0.3 volt range). The values from point to point along the structure can show marked variation. This is an indication of the existence of corrosion cells. For any two points on a non-cathodically protected structure, the point with the most negative reading is anodic with respect to the other point. To help understand this, Figure 5-6 will clarify the matter.

For the two points "A" and "B" which could, for example, be five feet apart, we get the conventionally-recorded figures (the upper set) of -0.150 volts and -0.210 volts with respect to the reference electrode. In the usual case, there would be no detectable

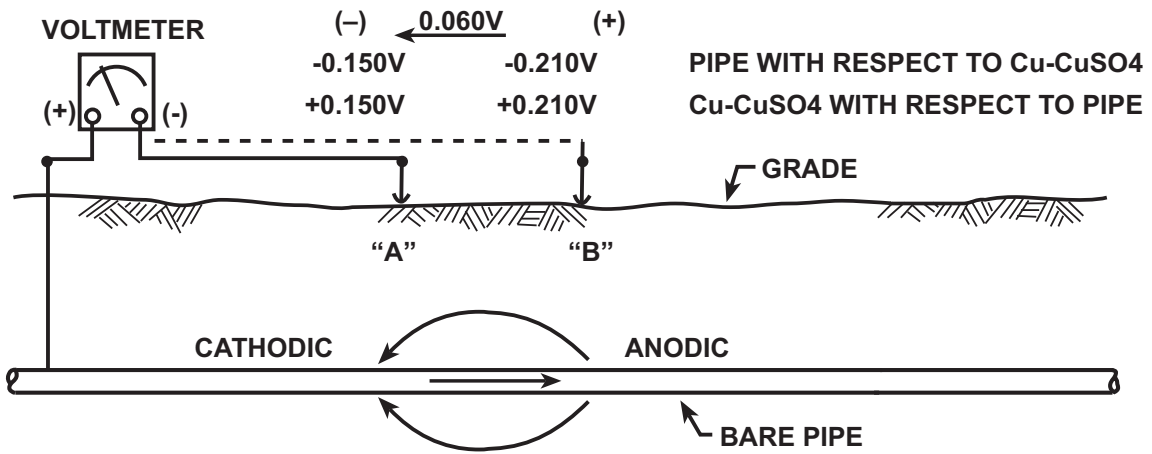

**CATHODIC AND ANODIC POINTS ON A
NON-CATHODICALLY PROTECTED STRUCTURE**

FIGURE 5-6

difference in the pipe itself between points "A" and "B" caused by voltage drop in pipe resistance from galvanic corrosion current flowing through the pipe between the two points.

Accordingly, we can temporarily reverse our thinking and treat the pipe as the reference rather than the saturated copper/copper sulfate reference electrode. Looking at it this way, the readings (lower set of figures) are +0.150 volts (saturated copper/copper sulfate positive with respect to pipe) at Point "A" and +0.210 volts at point "B". This means that the earth surface at point "B" is more positive than at point "A". Point "B" is then 0.060 volts positive with respect to point "A" (difference between the two figures). Corrosion current flow would then be as shown by the earth-path arrows confirming that point "B" is anodic with respect to "A".

Just two readings (as in the example above) are usually not enough to explore the complete extent of a corrosion cell. This is done by potential surveys as discussed later.

Whereas old bare steel structures have generally low negative potentials with respect to a saturated copper/copper sulfate reference electrode, non-cathodically protected new steel (and especially well coated new steel) can have potentials to a close reference electrode in the order of -0.70 volt or more. -0.800 volt is about the maximum for bright new steel.

Because the amount of corrosion current flowing to or from a well-coated pipe is extremely small, there is little possibility of significant voltage drops in the earth around the pipe. This means that a close reference electrode position directly above the pipe is essentially the same as one at a remote location. This would not be the case if there were strong stray earth currents in the area from some external DC source.

Point-to-point changes along the surface above a coated pipe tend to be much more gradual than on bare pipe.

CELL-TO-CELL POTENTIAL MEASUREMENTS

These are measurements between two reference electrodes. Two applications are illustrated by Figure 5-7.

Part A of Figure 5-7 shows one use of potential readings between a reference electrode over a structure such as a pipe and another reference electrode at one side of the structure. This procedure could be used to verify the flow of cathodic protection onto

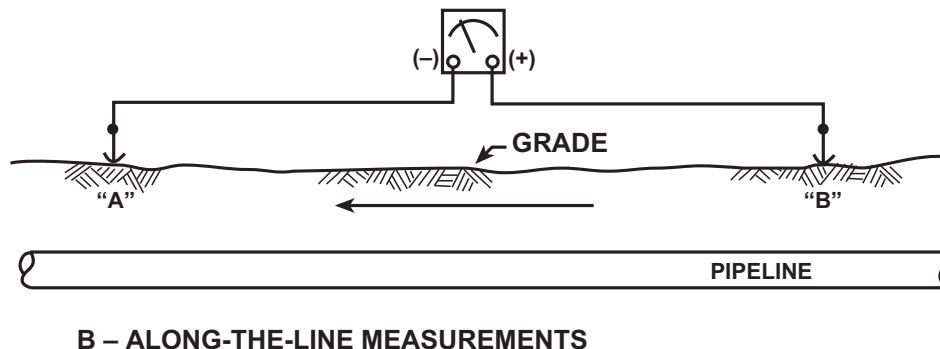
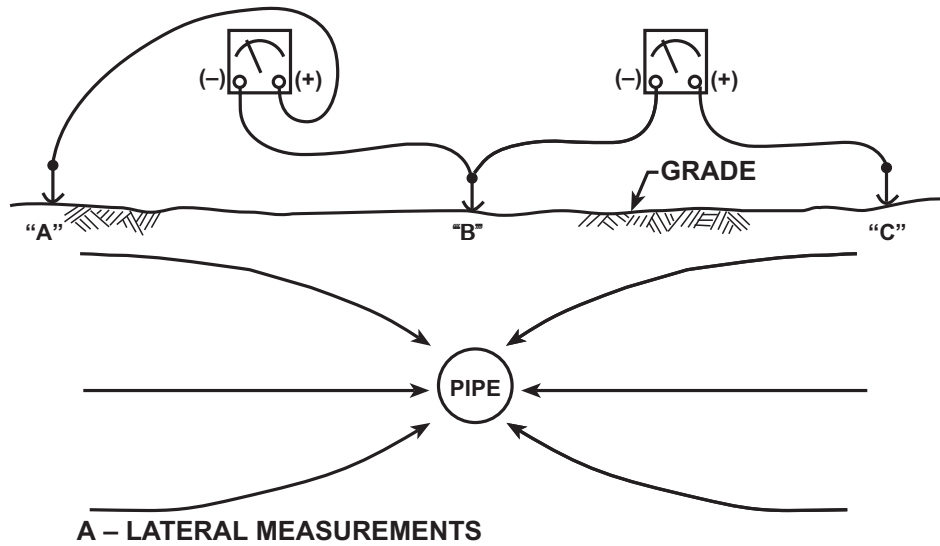

**CELL-TO-CELL
POTENTIAL MEASUREMENTS**

FIGURE 5-7

a bare structure, for example, or to trace the flow of stray earth currents around a structure.

If, in Part A of the figure, the voltage drop is measured between reference electrodes "A" and "B" and reference electrode "A" is positive with respect to "B" as shown this means that current is flowing toward the pipe. This is fine as it indicates that the pipe is cathodic. This is not necessarily the whole story. To confirm this, a potential reading between reference electrodes "B" and "C" will reveal what is going on on the other side of the pipe. If the polarity is as shown on the figure ("C"+), current is also flowing toward the pipe confirming the cathodic condition on the pipe.

If, however, reference electrode "B" is found to be (+) with respect to "C", this would mean that the current flow is away from the pipe on its right hand side - as could arise under certain stray current conditions. This results in the left side of the pipe being cathodic while the right side is anodic and corroding.

In Part B of Figure 5-7, the use of cell-to-cell measurements along a pipeline is illustrated. This usage, if there is a potential difference between the two electrodes, indicates a tendency for current flow in the earth. With electrode "B" in the figure being (+) as shown, the indication is that there is earth path current flowing from "B" to "A" as shown. It further indicates that there is an anodic area somewhere in the vicinity of (but not necessarily at) electrode "B". This assumes galvanic corrosion conditions.

In making cell-to-cell measurements, it must be remembered that there are two high resistance electrode-to-earth contacts in the circuit. This dictates care in taking the potential measurements to be sure that high circuit resistance is not affecting the readings - or if so, to make required corrections.

STRUCTURE-TO-STRUCTURE POTENTIAL MEASUREMENTS

Measurements between underground structures (or between different parts of the same structure) often are used in conjunction with structure-to-earth measurements. They can serve as a quick screening method to establish continuity - or lack of it.

Figure 5-8 illustrate some typical uses.

Part A of Figure 5-8 shows a potential measurement across an isolating joint used in a piping system to separate a cathodically protected section of the system from an unprotected one. If everything is in good working order there will be a reading on the

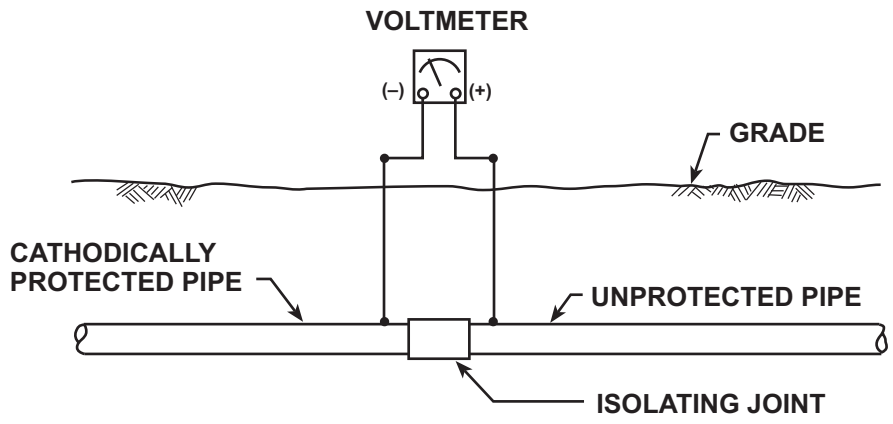

PART A

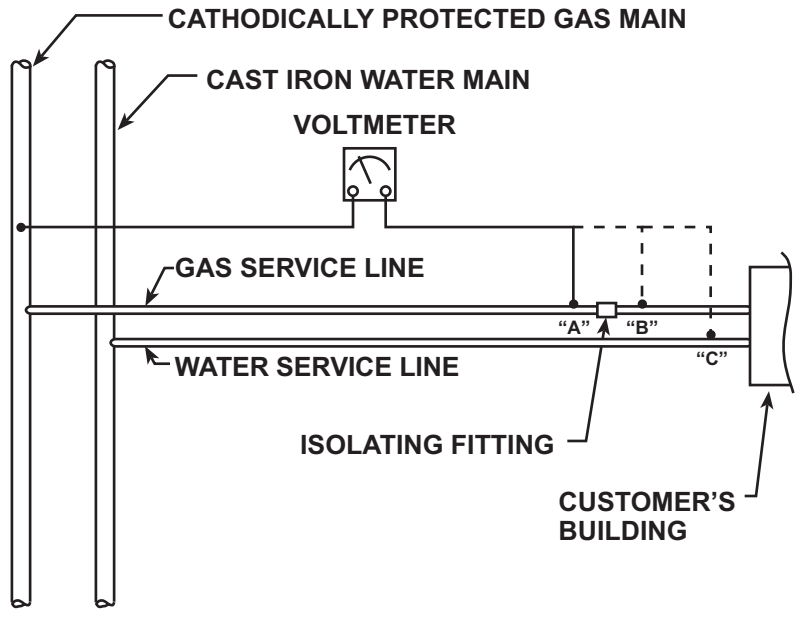

PART B

**STRUCTURE-TO-STRUCTURE
POTENTIAL MEASUREMENTS**

FIGURE 5-8

voltmeter, which will depend on the potentials to earth of the cathodically protected and non-protected piping. The difference between the two potentials will be the numerical value shown on the voltmeter. The amount could range from, for example, 0.25 volt or less to 1.50 volts or more. The unprotected piping section would be positive in polarity to the cathodically protected pipe (which is more negative to earth).

If the voltmeter reads zero, it is an indication that something is wrong. The question is what? Here are some of the possibilities:

- The isolating joint is "shorted" (no longer isolating).
- The isolating joint is perfectly OK but a parallel metallic path has been established around the isolating joint (such as gas instrumentation piping for example).
- The cathodic protection system is "off" for whatever reason and the potentials to earth on the two sides of the isolating joint are exactly the same. This is highly improbable - but possible.

It becomes obvious from the above that the reason for the zero voltmeter reading cannot necessarily be deduced from the voltmeter reading alone. Additional tests will be necessary which, depending on the conditions of the situation, may involve structure-to-earth potentials, current flow on the structure, use of a pipe locator to trace the path of the pipe locator transmitter signal, etc.

Part B of Figure 5-8 represents a situation common to gas and water distribution piping systems in urban areas. Shown is a cathodically protected gas main with services to a customer's property. Let's assume a coated steel main with a coated steel service line which is electrically continuous with the main but provided with an isolating fitting where it enters the customer's building. Also shown is an unprotected water main with service line to the same customer's property - and possibly buried in the same ditch with the gas service line. Assume that the water main is bare cast iron and that it has a bare copper service line. The two systems must be kept electrically separate if the cathodic protection installation on the gas system is to be fully effective.

In Part B of Figure 5-8, several points are shown at which potentials between each such point and the gas main can be measured. If all is as it should be, the potential between gas main and Point A should be zero. This indicates that the service pipe is electrically continuous with the gas main plus the probability that the isolating fitting in the service line is functioning as it should otherwise there would be current flowing on the service

line which would cause some voltage drop through the service pipe resistance.

The potential between the gas main and Point B should be significant (0.25 volts or less to 1.5 volts or more) with Point B being positive (+) to the gas main. This is further indication that the isolating fitting is satisfactory.

Typically, the potential between the gas main and Point C (on the water service line) will be equal to the value measured to Point B. This is because the various services entering a customer's property (gas, water, electricity) are usually in electrical contact with each other within the customer's building.

If the potential readings do not show an acceptable pattern, some things to look for with supplemental tests include:

- Electrical discontinuity in the gas service line could result from the accidental use of an isolating fitting at the main tap or could be from the use of a mechanical compression type coupling which accidentally did not provide electrical continuity.
- Failed isolating fitting in the service line where it entered customer's building.
- Electrical contact between gas service line and water service line.
- Electrical contact between gas and water at some property or at some point other than the one being tested.

When making contact with structures for potential measurements, a permanent test wire is best - if there is one. In many cases, however, there will not be a test wire available and it may be necessary to make the connection by clipping or clamping the instrument test lead to a convenient point on the structure. Or if this is not possible, to use a pointed device (such as a scratch awl with a hardened tip) held against the structure with the instrument lead connected to the tool used. Obviously these are connections made to fit the situation but are perfectly satisfactory if carefully done and provided that all such connections are to bright metal surfaces. If, for example, there were a bit of mill scale between the contacting surfaces, extraneous voltages could be introduced into the circuit and the potential observed on the voltmeter would not be the true potential desired.

POTENTIAL SURVEYS

Potential surveys are useful in determining the location of anodic (corroding) areas on non-cathodically protected structures or when making a detailed evaluation of the performance of cathodic protection systems.

In substance, the potential survey consists of making close interval measurements to a saturated copper/copper sulfate reference electrode along extensive structures such as pipelines. This permits a reasonably complete coverage so that major anodic areas can be identified on non-cathodically protected lines or so that below-standard protective potentials on cathodically protected systems will be revealed.

Potential surveys can be made in various ways. Some of these are illustrated by Figure 5-9.

In Part A of Figure 5-9, a two-electrode survey method is shown. It works in this fashion. At a permanent test point, the potential of the pipe is measured to saturated copper/copper sulfate reference electrode "A" and recorded. Then reference electrode "B" is placed at the preselected survey distance (5 ft. for example) along the pipe and directly above it. The potential between the two electrodes is then measured and numerically added or subtracted from the prior reading in accord with the polarity [(+) or (-)] of the forward electrode ("B" in this case). Electrode "A" is then moved to the survey spacing distance beyond "B" and the potential between the two electrodes measured and numerically added or subtracted from the prior figure. This "leap-frogging" of the two electrodes is continued until the next permanent test point (or other location) where the structure can be directly contacted. At this point, the cumulative potential up to this point is compared with the actual potential to a saturated copper/copper sulfate reference electrode and corrected as necessary. The survey then continues in the same fashion to the next access point.

The manner in which the data would be recorded would be in general accord with the following:

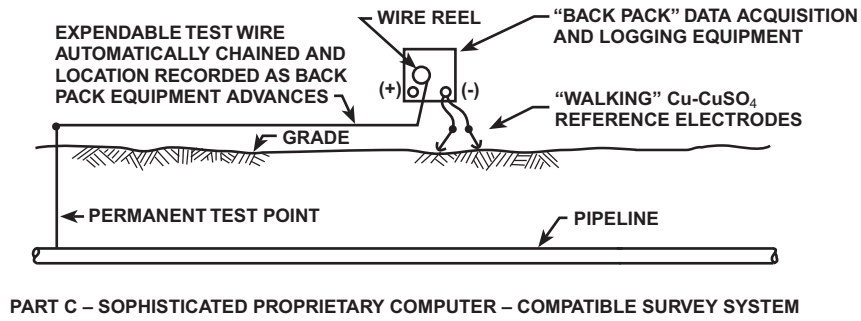
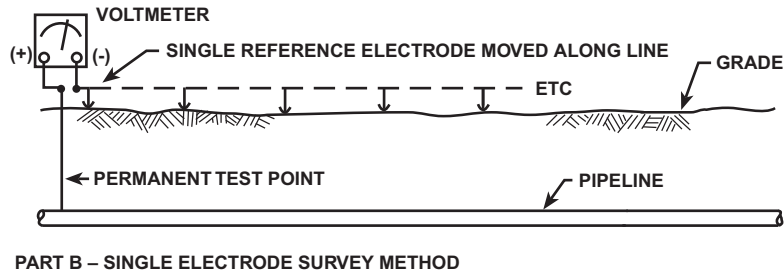
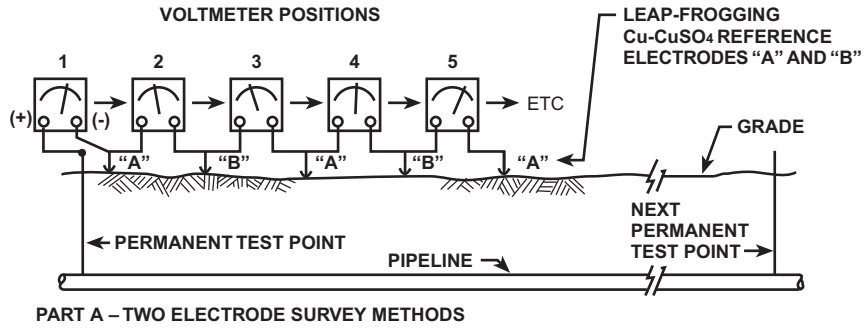

POTENTIAL SURVEY METHODS

FIGURE 5-9

Test	Pipeline Station No.	Potential Between Electrodes	Polarity of Forward Electrode	Pipe to Cu-CuSO ₄ Potential
Pipe to Cu-CuSO ₄ at Test Point at	672+15			-0.573
Cu-CuSO ₄ at Test Point to Cu-CuSO ₄ at	672+20	0.015	(+)	-0.588
Cu-CuSO ₄ at Sta 672+20 to Cu-CuSO ₄ at	672+25	0.023	(+)	-0.611
Cu-CuSO ₄ at Sta 672+25 to Cu-CuSO ₄ at	672+30	0.012	(-)	-0.599

Although the two-electrode survey system works, it does take a great deal of care in recording data both as to amount of potential difference between electrodes and the polarity of the forward electrode. An error at any one point is then present in all subsequent calculated pipe to saturated copper/copper sulfate potential readings. Should this be the case, the calculated pipe to reference electrode potential will not check with the actual pipe to reference electrode potential when the next test point (or other pipe access point) is reached. This could possibly necessitate a repeat survey of the section - but see the following paragraph.

It should be pointed out, however, that even if there were no data errors, there could still be a difference between the last calculated pipe to saturated copper/copper sulfate potential and the actual measured pipe to saturated copper/copper sulfate potential at the next pipeline test point or other access point. There could be two possible reasons for this. First, if there is any long line direct current flowing on the pipe, the voltage drop in the pipeline resistance between the two test points could account for the difference. Second, if there is any stray current activity, natural or man-made, which is affecting the pipeline potential, it, too, could result in a difference.

It is important that the two electrodes used be leap-frogged as described. This is to compensate for any slight potential difference between the half-cell potentials of the

two electrodes. The leap-frogging action makes this potential difference additive on half the readings taken and subtractive on the other half - thus nullifying the effect of any potential difference between electrodes.

In Part B of Figure 5-9, a single electrode survey method is shown. This accomplishes the same purpose as describes for the two-electrode method. The difference is that instead of moving the voltmeter from point to point along the line, it is stationed at a permanent test point (or other pipeline across point) and the reference electrode moved from point to point along the line using a long connecting test lead.

This method avoids the problem of an error in reading at any one point affecting all subsequent readings as is possible with the two-electrode method.

The disadvantage is that when the data has been taken between two permanent test points (or other pipeline access points), it is necessary to retrieve the long test leads before starting the next section.

At the forward end of the section surveyed from the first test point, the pipe to reference electrode potential measured at the next test point via the long test lead may not agree with the potential measured with the voltmeter at the second test point. Reasons for the disagreement, if any, could be as set forth in the prior discussion of the two-electrode survey method.

In Part C of Figure 5-9, a conceptual representation is made of a high technology over-the-line potential survey system. In this system, the voltage measuring equipment and data logging equipment can all be carried in a compact back pack by the surveyor. The surveyor carrying the equipment carries two saturated copper/copper sulfate reference electrodes which are "walked" forward at approximately two and a half foot intervals. Potential measurements are recorded electronically (avoiding human error) in the equipment storage module. The long test lead from the survey starting point can be a one-time-use disposable test lead. As it is released from the back pack reel as the surveyor moves forward, the distance from the survey starting point is automatically measured and recorded in the data storage module along with the potential measurements. The surveyor is also able to electronically enter notes on terrain features or other identifiable landmarks, as well as data necessary to identify the pipeline section being surveyed.

The electronically recorded data package is processed by the home office computer programmed to produce a plotted profile, complete with notes, for the pipeline section

surveyed. If desired, the last previous survey can be computer-plotted at the same time so that any changes since the last survey will be visually displayed.

Common to all survey methods is the need to locate a pipeline so that the reference electrodes are placed directly above the pipe as the survey progresses. This is normally done with a pipe locator operator (moving ahead of the data acquisition team) who locates and stakes the line.

Although a more detailed discussion of potential survey work and analysis thereof is contained in Chapter 1 of the Advanced Course, Figure 5-10 is included to give an initial idea of what might be expected of plotted data from a pipeline potential survey. The figure gives an indication of variations typical of a survey taken along a section of bare or very poorly coated pipeline.

Within the section illustrated, the peaks in the plotted data (where the pipe is most negative with respect to a saturated copper/copper sulfate reference electrode) represent anodic areas. This is in accord with the discussion on this subject earlier in this chapter under the heading, Structure-to-Earth Potential Measurements. The Figure 5-10 plot shows that insofar as potential differences are concerned, there is one major peak (designated as a major anodic area) and three minor peaks within the slopes leading to the major peak. The major peak could be caused by a long line galvanic corrosion cell while the lesser peaks could be the result of more localized corrosion cells.

As has been discussed earlier in the course, a corrosion cell having a given driving potential will cause more current to flow through low resistivity earth and hence cause more corrosion than will be the case where the earth resistivity is high. This means, then, that potential is not the whole story. Earth resistivity must be considered as well. If the plot of Figure 5-10 represented an actual situation, it could be quite possible for one of the "lesser" anodic areas to be in a local section of very low resistivity soil and causing more corrosion than the designated "major" anodic area which may be in generally much higher resistivity earth.

The following chapter will include methods for measuring earth resistivity.

A plot of over-the-line potentials made along a well coated pipe would not ordinarily (in the absence of any stray current effects) have the marked variations as shown in the Figure 5-10 plot. Rather, there would be gradual rises and falls in a generally smooth curve. This is because the reference electrode directly above the pipes is, for all intents and purposes, in electrically remote earth because of the high resistance coating barrier

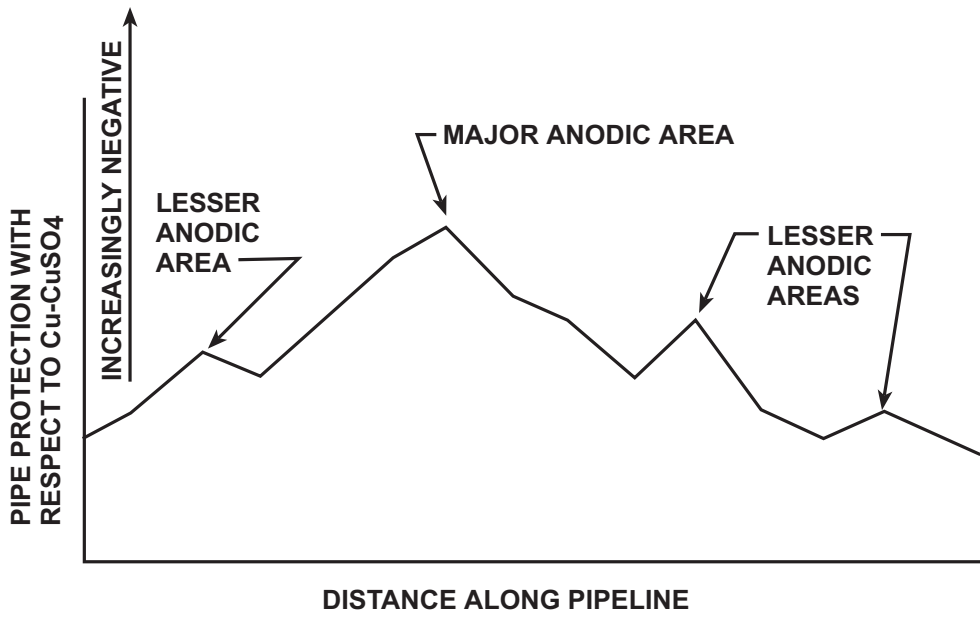

PLOTTED POTENTIAL SURVEY DATA

FIGURE 5-10

and will generally not reflect conditions right at small pinholes or small defects in the coating. Should however there be a major coating holiday (such as a foot or so of bare pipe), close-spaced readings could be expected to reveal its presence by a local variation in the otherwise smooth curve. There can be other effects as well which will be discussed in the Advanced Course.

POLARIZATION EFFECTS ON POTENTIAL

The discussion earlier in this chapter under the heading, "Structure-to-Earth Potential Measurements," covered the nature of a potential measurement between the structure and a saturated copper/copper sulfate reference electrode contacting adjacent earth. At this point, it is appropriate to explore the effect of polarization (and depolarization) on such a reading.

Part A of Figure 5-11 shows the general shape of a polarization curve. If a voltmeter is connected to measure structure to saturated copper/copper sulfate potential at a test point on a non-protected structure, a steady state potential (in the absence of stray current effects) will be observed as represented by the horizontal line of the Part A representation. If, while watching the voltmeter, cathodic protection current is applied to the structure, there will be an immediate potential increase caused by voltage drop in the earth resulting from cathodic protection current flow to the structure. This will be followed by a more gradual increase as cathodic polarization builds up.

If the structure is bare or poorly coated, the time required for full polarization may be days or weeks because of the large areas to be polarized. On the other hand, a very well coated structure can polarize very quickly - seconds to minutes.

Part B of Figure 5-11 represents the reverse situation showing depolarization when cathodic protection current is interrupted. Under depolarization, as opposed to polarization, depolarization of a bare structure tends to be relatively rapid during early stages compared to the rate of depolarization on a well-coated structure.

CRITERIA FOR CATHODIC PROTECTION

Although a more complete discussion of criteria for cathodic protection is included in the Intermediate Course, there are two potential-dependent criteria, which should be mentioned here, which are in addition to the -0.85 volt potential to a saturated copper/copper sulfate reference electrode (for steel structures) as discussed in Chapter 3 under the heading, "How Cathodic Protection Works."

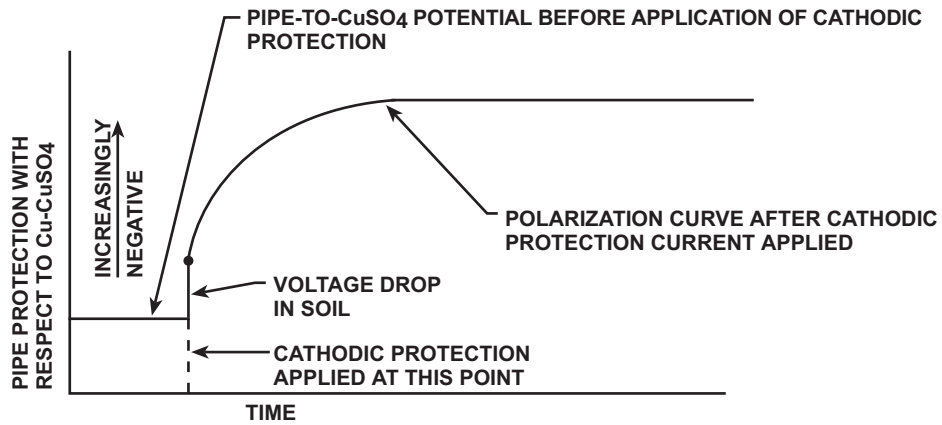

PART A – POLARIZATION

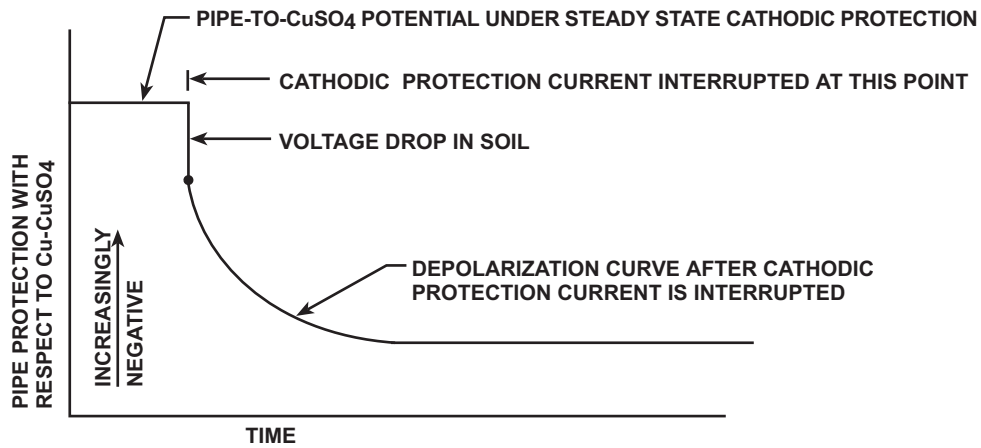

PART B – DEPOLARIZATION

POLARIZATION AND DEPOLARIZATION

FIGURE 5-11

The first of these is the criterion which uses at least 100 millivolts of structure polarization as an indication of cathodic protection. This can be determined on a structure where all sources of cathodic protection current affecting that structure can be interrupted at the same instant. With a voltmeter set up to measure structure to saturated copper/copper sulfate potential prior to interrupting the current, watch the voltmeter as the cathodic protection current is interrupted. Normally there will be an immediate drop followed by a slight hesitation (particularly detectable on an analog voltmeter) which is the start of the depolarization curve. Note the voltmeter reading at that point. Then if there is at least 100 millivolts of depolarization beyond that point, the criterion has been met. If the structure is one that depolarizes very slowly, it could take quite some time to reach the 100 millivolts of depolarization. In this case, it may be helpful to plot potential change with time and then extend the curve to see if it appears that the 100 millivolts of depolarization will be attained. If the indications from this are positive, it is then worthwhile to continue the test until the objective is attained.

The second potential-dependent criterion uses a 300-millivolt shift in the negative direction from the structure to reference electrode potential prior to applying cathodic protection to the potential attained with cathodic protection applied. This may be used in instances where a potential of -0.85 volt (on steel structures) is not attained. This is not as sound a criterion as the -0.85 volt criterion (for steel) or the 100-millivolt polarization criterion. It has, however, had reasonably good results. This criterion was dropped from the list of criteria in Section 6 of NACE SP0169. Although still recognized and listed as a criterion for cathodic protection in Appendix D to Part 192 of the CFR, it is being interpreted by inspectors as 300 mV of cathodic shift after correction for IR Drop. In effect, they are requiring a 300-mV polarization shift.

MONITORING CATHODIC PROTECTION SYSTEMS

Potential measurements are used to periodically verify that cathodic protection on a structure, once attained, continues to be effective. This monitoring can be performed on pipelines by periodic over-the-line potential surveys as discussed earlier in this chapter. At intervals between complete surveys, pipe to saturated copper/copper sulfate potentials can be measured at test points along the line.

There is one caution that should be observed when taking such measurements at test points. This is to avoid placing the reference electrode close to a buried galvanic anode connected to the line. If the reference electrode is placed on the surface above such an anode, the potential reading between pipe and reference electrode will include the voltage drop in the earth caused by current discharge from the anode. For this reason,

the reading obtained will not reflect the correct potential between pipe and earth. For example, if the reference electrode were placed above a magnesium anode, the reading between pipe and saturated copper/copper sulfate might be -1.15 volt which looks just great - whereas with the reference electrode above the pipe fifteen feet away from the magnesium anode, the reading might be only -0.65 volt. This is quite another story since the pipe is not fully protected.

As a rule of thumb, it would be well to place the reference electrode at least fifteen feet from the nearest working galvanic anode. Also, any abnormally high readings could lead one to suspect the presence of a galvanic anode even if its existence is not known. Checking potentials either side of the high reading point should then clarify the matter.

Chapter 6 – Resistance and Current Measurements

INTRODUCTION

In Chapter 5 we learned about measuring voltages. In this chapter we are going to learn about measuring the other two parts of Ohm's Law: Resistance and Current.

RESISTANCE MEASUREMENTS

Introduction to Resistance

The electrical resistance of an object is a measure of its opposition to the flow of electric current. It is typically expressed in units of ohms. The Greek letter "omega" (Ω) is the symbol for ohms.

In corrosion control testing we may be interested in knowing the value of resistances like:

- The resistance across a wire, a reel of wire, a bond, a shunt or a resistor
- The resistance across an electrical isolation device
- The resistance across a pipeline span
- The resistance between a pipeline and earth
- The resistance between an anode bed and earth
- The resistance or resistivity of soil

Measuring a Simple Resistance

Measuring the resistance across an object that has been temporarily isolated electrically, is often referred to as a "Simple Resistance" measurement. This includes such items as resistors, current measurement shunts, stray current bond cables, instrument test leads and reels of test wire.

These resistance measurements are simple applications of the basic electric circuit as was discussed in Chapter 1. All that is needed for this measurement is a battery, a voltmeter, an ammeter and test leads. Figure 6-1 shows the resistance measurement circuit based on the material contained in Chapter 1.

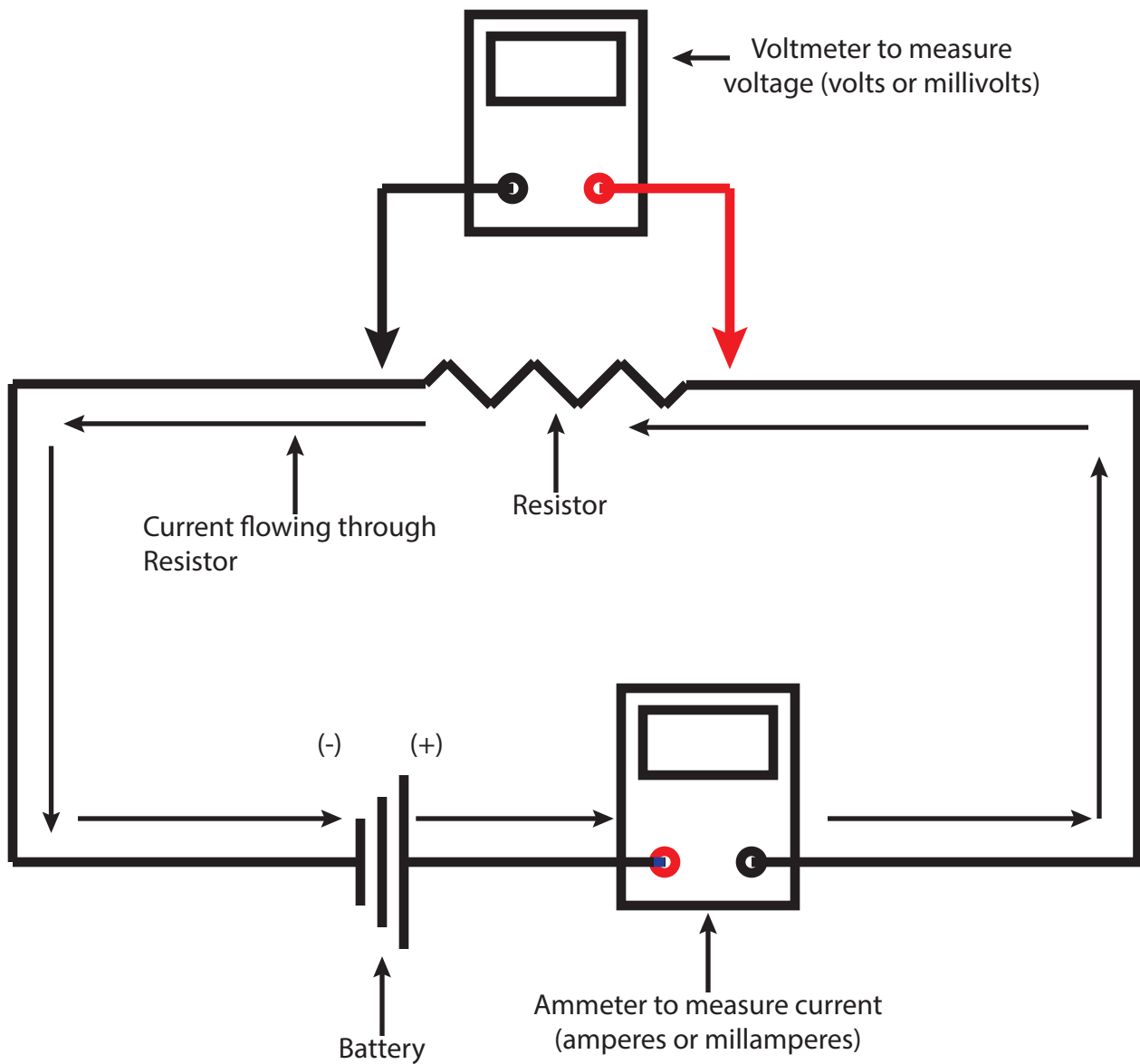

$$R = \frac{E}{I} = \frac{1.21 \text{ V}}{0.0676 \text{ A}} = 17.899 \Omega$$

Measuring a Simple Resistance
Figure 6-1

To measure the resistance across an object, connect as shown in the sketch. For example, see Figure 6-1: $E = 1.210$ volts and $I = 67.6$ milliamps. Now apply Ohm's law where $R = E/I$. Remember to keep units in the same order by either converting the voltage reading to millivolts or converting the milliamps reading to amperes. Choosing the latter, the result is:

$$R = E/I = 1.210 \text{ V}/0.0676 \text{ A} = 17.899 \Omega$$

With typical test instruments, it is possible to accurately measure resistors ranging from a thousandth of an ohm (0.001 ohm) or less, up to tens of thousands of ohms (10,000 ohms).

Most multimeters have a built-in ohmmeter that can be used to measure simple resistances. These are especially useful for measuring the resistance of test leads and reels of wires.

Delta Values in Resistance Tests

Before proceeding further, it is time to consider "delta" values and their use in Ohm's Law. The symbol Δ means "change in" and is normally read as "delta." Delta is the "On" value minus the "Off" value. For example, $\Delta E = E\text{-On} - E\text{-Off}$ and $\Delta I = I\text{-On} - I\text{-Off}$. Delta calculations must include the polarities of the measurements.

In the example above, we caused a change in the voltage from 0 to 1.210 volts using a change in test current from 0 to 0.0676 A. So:

$$\Delta E = 1.210 \text{ V} - 0 \text{ V} = 1.210 \text{ V}$$

$$\Delta I = 0.0676 - 0 \text{ A} = 0.0676 \text{ A}$$

When calculating resistance, we need to use the Δ values so Ohm's Law should be stated as $R = \Delta E / \Delta I$. In the example above, E-Off and I-Off were both zero so considering the Δ was not necessary. However, in most cases in the field, E-Off will not be zero and ΔE must be used. In most cases when we use a test current, I-Off will be 0 since our test circuit is open and $I\text{-On} = \Delta I$.

Resistance of Electrical Isolation Devices

An effective electrical isolation device must have a very high resistance through it. It might seem logical that by measuring the resistance across it as shown previously, we can determine if it is effective. The key difference here is that in the case of an installed device, unlike with a simple resistance, we cannot temporarily isolate the device electrically since the two sides of the device are in the earth. If we connect as shown previously, there are two parallel paths for the test current to flow: through the device (the path we care about) and through the earth.

Figure 6-2 shows a set up using the simple resistance measuring circuit shown previously with some data as an example. The first thing you might notice is the voltmeter reads 0.19 V, right hand side of isolating joint positive, before the current circuit is connected. The fact that the voltage across the device is not zero indicates that there is some resistance across it.

After the current circuit is closed, the ammeter reads 0.0676 amperes while the voltmeter reads 1.21 volts, right hand side of isolating joint positive. To calculate the resistance:

$$R = \Delta E / \Delta I$$

$$R = (1.21 - 0.19 \text{ V}) / (0.0676 - 0 \text{ A}) = 15.089 \text{ ohms}$$

But this not the resistance through the device. Figure 6-3 shows why. The resistance that has been calculated is that across a parallel resistance circuit like was shown in Chapter 1. One of the parallel resistors is the electrical isolation device, the resistor we care about. The other parallel resistor is the resistance-to-earth of the pipe on one side of the device plus the resistance-to-earth of the pipe on the other side of the device. All we know is that the resistance that was measured is less than the smaller of the two parallel resistance paths. The resistance measured tells us nothing about the effectiveness of the electrical isolation device. The purpose of this example is to demonstrate that measuring the resistance across an installed electrical isolation device is not a way to determine its effectiveness. There are other ways to test an electrical isolation device such as the use of radio frequency insulation checkers. Other methods will be discussed in the Intermediate Course.

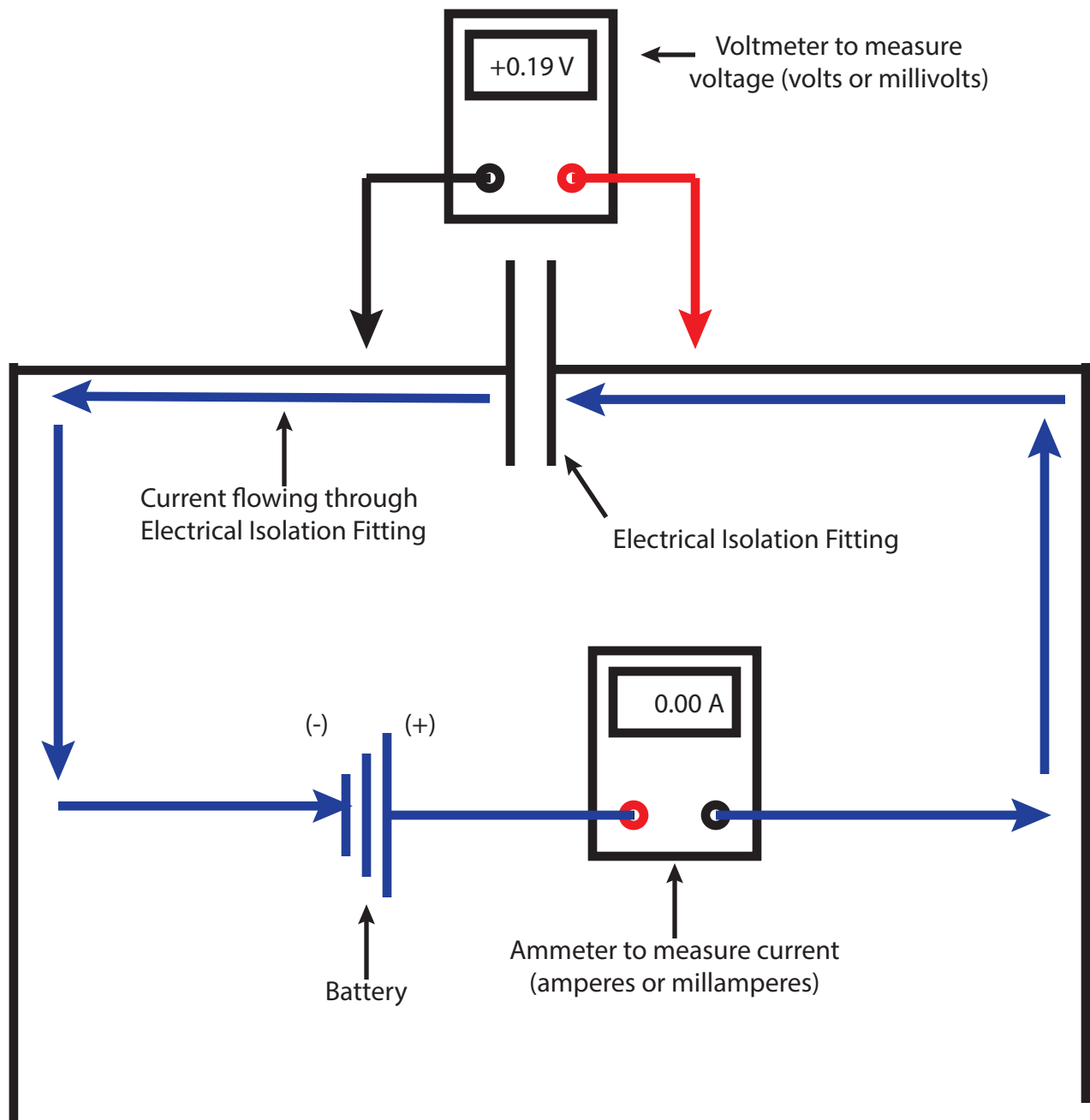

$$R = \frac{\Delta E}{I} = \frac{E_{\text{ON}} - E_{\text{OFF}}}{I} = \frac{1.21 \text{ V} - 0.19 \text{ V}}{0.0676 \text{ A}} = 15.809 \Omega$$

Measuring Resistance Across an Electrical Isolation Fitting
Figure 6-2

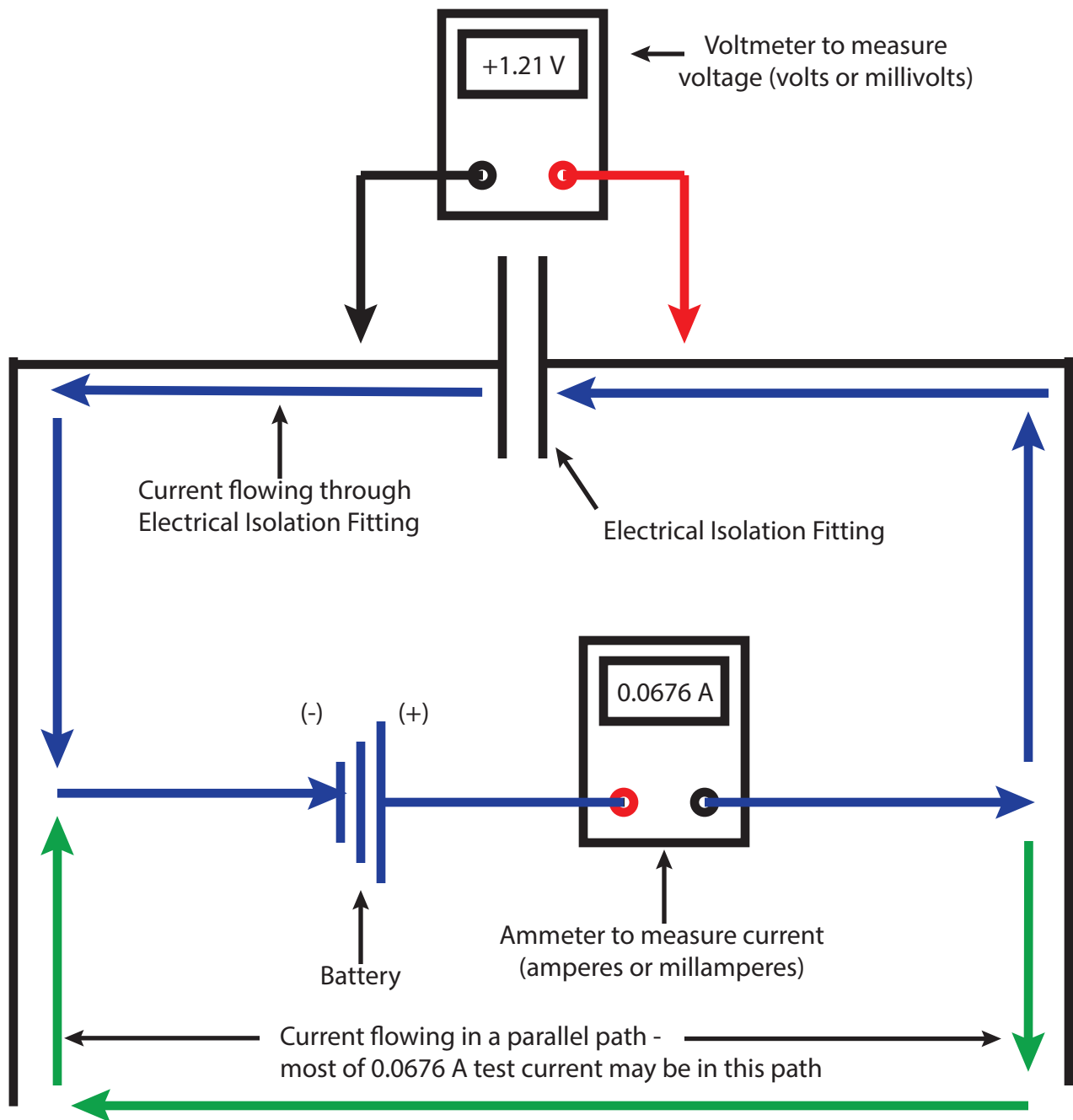

$$R = \frac{\Delta E}{I} = \frac{E_{ON} - E_{OFF}}{I} = \frac{1.21 \text{ V} - 0.19 \text{ V}}{0.0676 \text{ A}} = 15.809 \Omega$$

Measuring Resistance Across an Isolating Fitting - Parallel Paths
Figure 6-3

Resistance-to-Earth of Pipelines and Anode Beds

Knowing the resistance-to-earth of a pipeline can help us evaluate its coating quality, determine its cathodic protection current requirements and determine if it is electrically isolated. The higher the resistance-to-earth of a pipeline, the better the coating and the lower the current requirements. If the resistance-to-earth of a pipeline is unusually low, it may not be electrically isolated, and troubleshooting may be needed.

Knowing the resistance-to-earth of an anode bed can help us evaluate the anode bed. The lower the resistance-to-earth of an anode bed the better. If the resistance-to-earth of an anode bed has increased from previous values, it may indicate depleted anodes or a cable break.

Measuring the resistance-to-earth of a pipeline or an anode bed can be done using the same test set up.

Figure 6-4 shows a typical set up for measuring the resistance-to-earth of a structure.

A current circuit and a voltage circuit are set up.

In the current circuit, a DC current source such as a battery is connected between the structure and an earth ground. The earth ground can be any metal that is in the earth. A low resistance ground works best. An ammeter is placed in the current circuit so that the test current can be measured.

In the voltage circuit, a voltmeter used to measure the structure-to-soil voltage to a reference electrode like a CSE. When the current circuit is closed, current will flow through the earth between the structure and the ground and the structure-to-soil voltage will change. The resistance-to-earth of the structure can be calculated using Ohm's Law.

As an example, see Figure 6-4:

A test current of 2.2 amperes is applied between a pipeline and a ground.

The test current causes the pipe-to-soil voltage to change from -1.00 volts to -9.80 volts.

Current Circuit

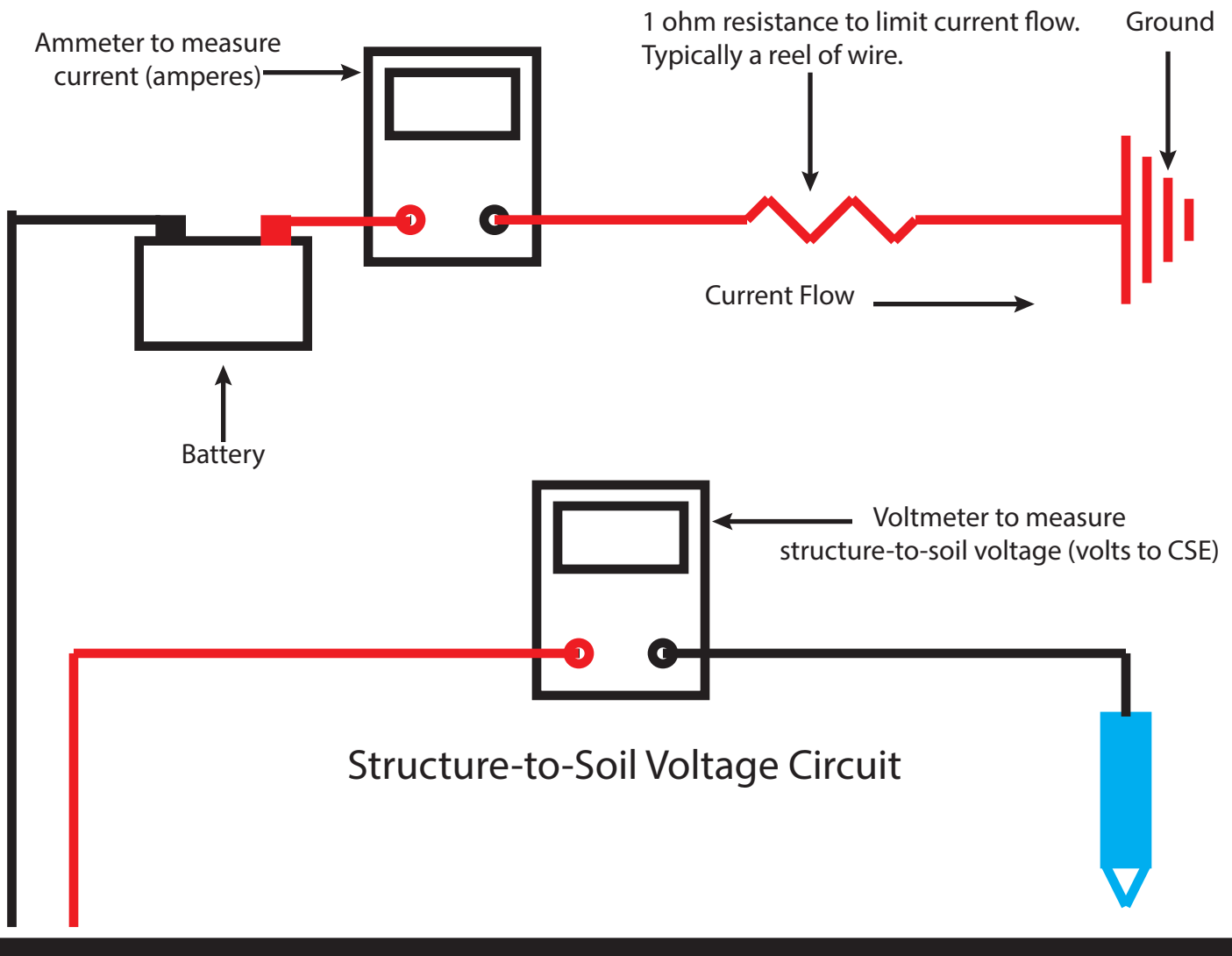

$$R = \frac{V_{ON} - V_{OFF}}{I} = \frac{9.80 \text{ V} - 1.00 \text{ V}}{2.20 \text{ A}} = 4.00 \Omega$$

Measuring the Resistance-to-Earth of a Buried Structure

Figure 6-4

$$R = \Delta V / \Delta I$$

$$\Delta V = (-9.80 \text{ V}) - (-1.00 \text{ V}) = -8.80 \text{ V}$$

$$\Delta I = 2.20 \text{ A} - 0 \text{ A} = 2.20 \text{ A}$$

$$R = 8.80 \text{ V} / 2.20 \text{ A} = 4.00 \text{ ohms}$$

Note that we have ignored the negative sign in ΔV when calculating the resistance since resistances are always positive.

Resistance of a Pipeline Span

Another resistance we may be interested in knowing is the resistance of a pipeline span. Since the primary purpose of knowing the resistance of a pipeline span is to calculate current, we will discuss this measurement later in this chapter.

SOIL RESISTIVITY MEASUREMENTS

What is Soil Resistivity?

Resistivity is a property that quantifies how strongly a material opposes the flow of electric current. A low resistivity indicates a material that readily allows the flow of electric current. A high resistivity indicates a material that resists the flow of electric current. Soil resistivity values are used in the evaluation of soils as to their corrosivity and in the design of anode beds. Soil resistivity is typically expressed in units of ohm-cm. The Greek letter "rho" (ρ) is commonly used to designate resistivity.

Soil Resistivity and Soil Corrosivity

As was discussed in Chapter 2, low soil resistivities result in low circuit resistances for galvanic corrosion cells. This means higher current flow for a given cell potential and the higher current means more corrosion.

There are various rating systems for soil corrosivity as a function of soil resistivity. The following is one example:

Resistivity	Corrosivity
0 to 1000 ohm-cm	Very corrosive
1000 to 2000 ohm-cm	Corrosive
2000 to 10,000 ohm-cm	Mildly corrosive
10,000 ohm-cm and above	Progressively less corrosive

Rating systems like this are only a general guide. If soil resistivities in an area are well above 10,000 ohm-cm, this does not mean that there will be no corrosion, just that the tendency is less. And if there were local low resistivity inclusions within the generally high resistivity soils, corrosion could be quite active.

Measuring Soil Resistivity

Soil Box Procedure

This procedure is used to measure the resistivity of soil samples removed from excavations or auger holes. The resistivity may be measured on site or the samples may be placed in sealed plastic bags (to preserve moisture content), tagged as to location, date of removal, and other pertinent information and tested later in the laboratory.

To use a soil box, the potential pins are removed, and the box filled with the soil sample. The soil is compacted to the same degree as it was in the location from which it was taken. The potential pins are then inserted and the soil recompactd to ensure solid contact between the soil and the pins. The soil in the box is struck off flush with the top of the box so that the cross-sectional area of the soil sample is equal to that of the box. The sample is now ready for the resistance measurement.

Figure 6-5 shows a soil resistivity measurement using a soil box. The resistance is measured with an AC soil resistivity meter. The "C" terminals (current) of the meter are connected to the end plates of the soil box. The "P" terminals (potential) of the meter are connected to the potential pins of the soil box. With an AC soil resistivity meter, AC current passes between the end plates of the soil box. This AC current causes an AC voltage drop between the potential pins with the amount of the voltage being proportional to the soil resistivity. To make a measurement, the energizing button is pressed, and the dial rotated until the galvanometer reads zero. The range selector switch may have to be adjusted in the process. The ohms reading indicated

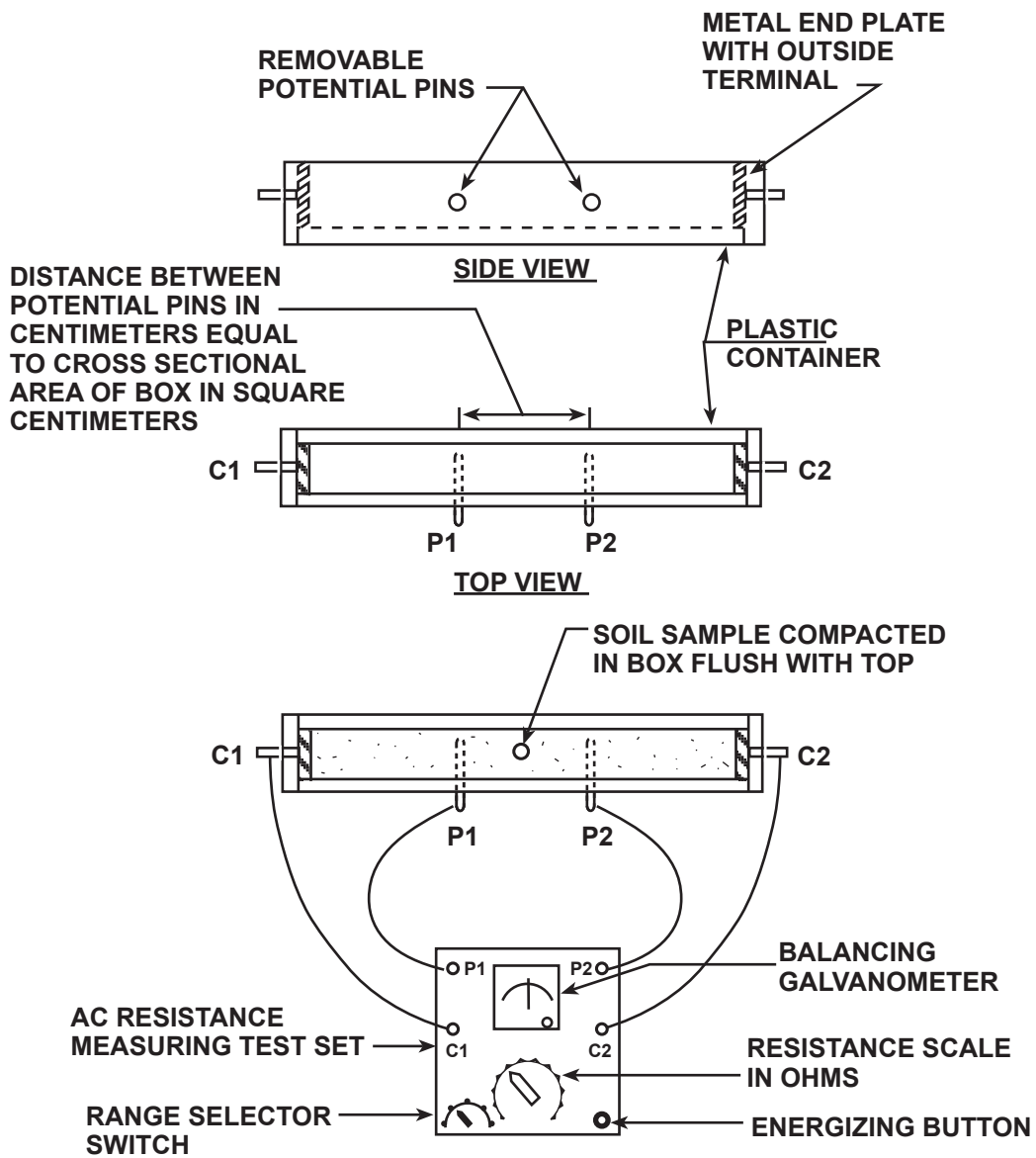

MEASURING RESISTIVITY OF SAMPLE

SOIL BOX MEASUREMENT OF SOIL RESISTIVITY

FIGURE 6-5

on the resistance scale is multiplied by the factor indicated by the range selector switch to give the measured resistance value in ohms. The resistance value is multiplied by the soil box factor to give the soil resistivity in ohm-cm. For the most common commercially available soil boxes the factor is 1, so the resistance measured in ohms is equal to the soil resistivity in ohm-cm.

The resistance can also be measured using the voltmeter-ammeter-battery method, as has been described in other applications. The ΔI , ΔV procedure should be used to eliminate polarization and galvanic effects. In the case of very high soil resistivities, resistance values may be beyond the range of an AC soil resistivity meter. The DC method may then be used.

The soil box may be used for measuring the resistivity of water samples in the same fashion.

The soil box should be cleaned thoroughly between tests to avoid contamination of the next sample.

It should be noted that an AC soil resistivity meter is not confined to soil resistivity measurements. It can be also be used to measure other resistances within its range. The range, depending on the equipment used, could be from about 0.1 ohm to 10,000 ohms.

Single Rod Test Procedure

For rapid accumulation of spot soil resistivity data along an underground structure such as a pipeline, the single rod resistivity equipment can be used. There are various designs commercially available.

The essential features of such a device are illustrated by Figure 6-6. The two exposed metal surfaces at the lower end of the tester shaft, when pushed into the ground, will have a resistance between them which is proportional to the resistivity of the soil immediately surrounding these tips.

In use, the rod is pushed into the ground to the desired depth (up to three or four feet), the test circuit actuating button depressed, and the soil resistivity read directly from the calibrated read-out.

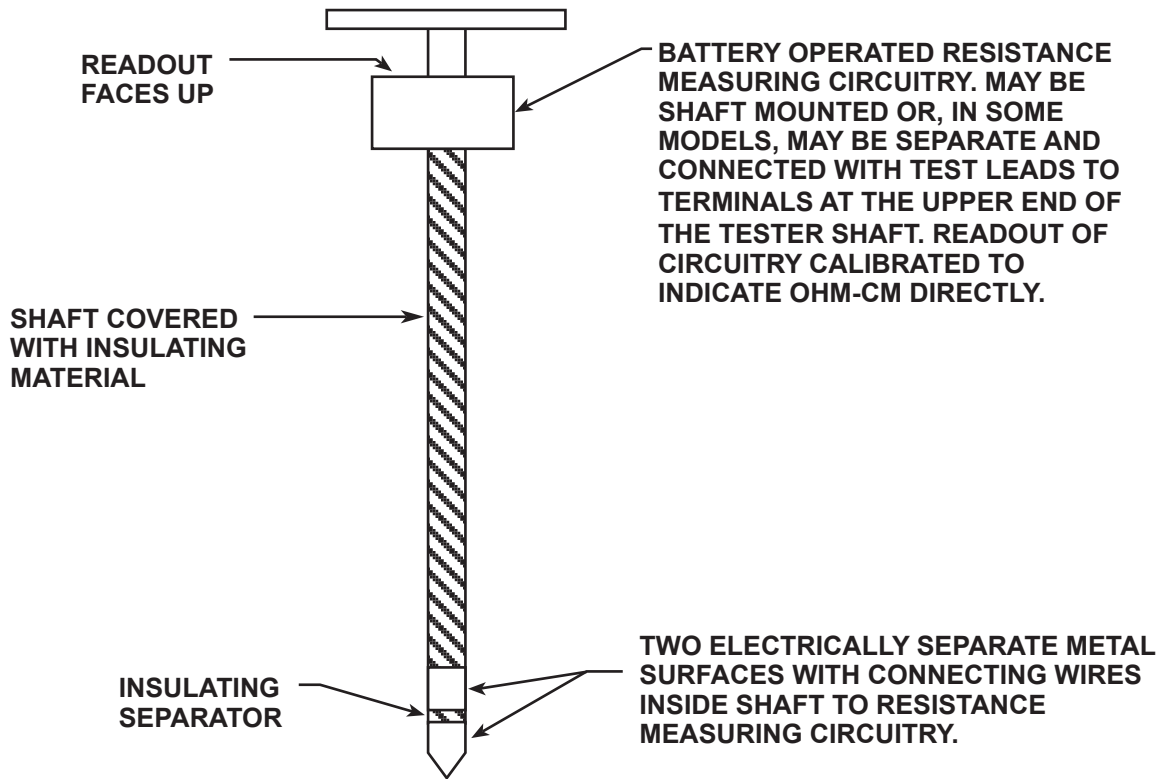

**SINGLE ROD
SOIL RESISTIVITY TESTER**

FIGURE 6-6

The single rod tester only measures the soil resistivity in a small local area, which was also true of the soil box technique. Because of the speed with which it can be used, it is useful in screening prospective sites for anode bed installations and then using mass soil resistivity techniques to explore the more promising locations indicated by the single rod equipment. It can also be used to measure the resistivity of soil at the edge of an excavation.

Wenner Four Pin Method

This procedure, as opposed to soil box tests or single rod tests, has the advantage of permitting the measurement of mass soil resistivities to various depths without having to go below the surface. This procedure is used widely for selection of cathodic protection anode bed locations and to accumulate the data necessary for their design.

The Wenner Four Pin or Four Point method is named for Dr. Frank Wenner who developed the theory and application of the procedure in 1915.

The arrangement of a 4-pin test setup is illustrated by Figure 6-7.

Four pins are pushed or driven into the ground (to a depth no more than 5% of the pin spacing) along a straight line with spacing between pins equal to the depth to which the average soil resistivity is to be measured. The size of the soil pins is not critical but can be ¼-inch or ⅜-inch rod two to three feet long and fitted with tee handles to facilitate handling. An AC soil resistivity meter, as was described in connection with soil box tests, can be used to measure the resistance. The “C” terminals (current) of the meter are connected to the outside pins. The “P” terminals (potential) of the meter are connected to the inside pins. The voltmeter-ammeter-battery method may also be used (using the $\Delta V, \Delta I$ procedure) but it is slower.

The measured resistance value is not the soil resistivity. The resistivity is a function of both the measured resistance and the pin spacing. For any pin spacing, the soil resistivity is determined by the following formula:

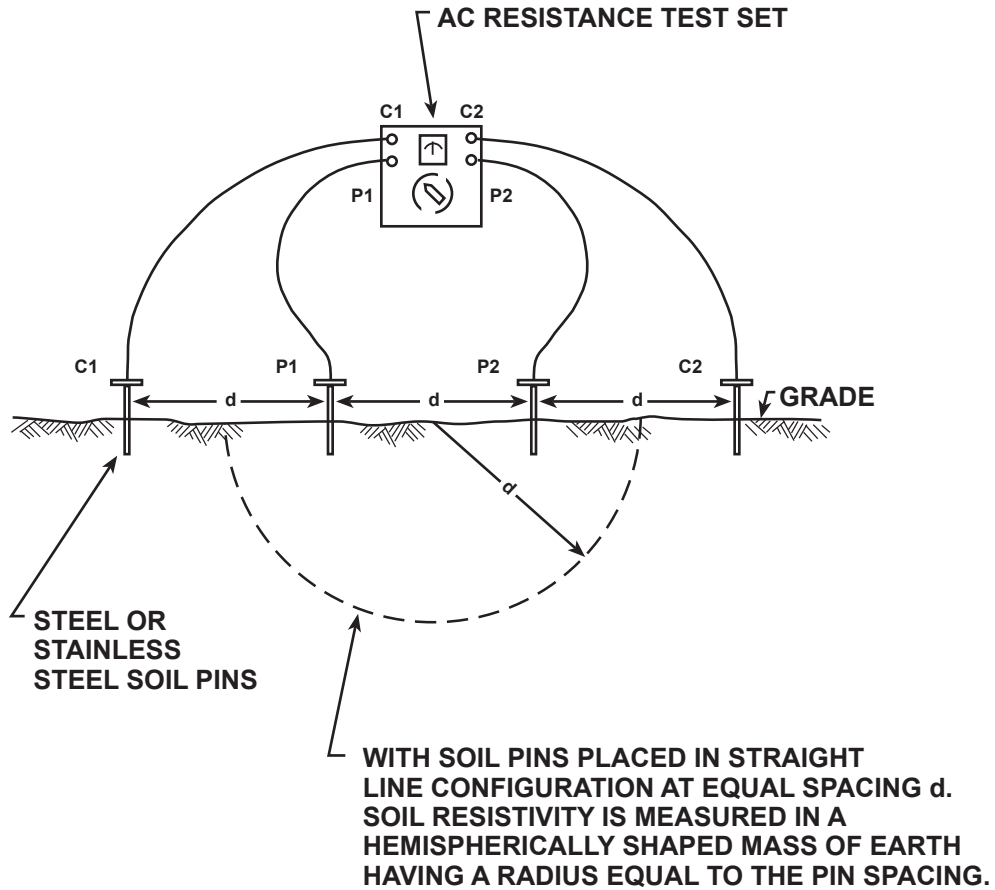

**SOIL RESISTIVITY MEASUREMENT
BY WENNER 4-PIN METHOD**

FIGURE 6-7

$$\rho = 191.5 \times D \times R$$

Where:

P = soil resistivity in ohm-cm

d = pin spacing in feet

R = measured resistance between P1 and P2 in ohms

As an example, assume that a test has been made with pins spaced 2.5 ft apart and that the measured resistance is 18 ohms. The soil resistivity will then be:

$$\rho = 191.5 \times d \times R = 191.5 \times 2.5 \times 18 = 8617.5 \text{ ohm-cm}$$

The soil resistivity so determined is a weighted average to the 2.5 ft depth. As indicated on Figure 6-7, the mass of earth "seen" by the measurement is a hemispherically shaped mass with the flat cross-sectional area of the hemisphere flush with the earth surface, and with the radius equal to the pin spacing and centered at a point midway between soil pins P1 and P2. It will be seen, then, that the average will be affected more by the substantially greater volume of earth in the top half of the hemisphere than by the bottom half.

CURRENT MEASUREMENTS

Introduction to Current

Electrical current is the flow of electrons in a conductor. It is typically expressed in units of amperes. The letter "I" is commonly used to designate current. The letter "I" originated from the term "current intensity". Wires and pipes are examples of conductors in corrosion control testing.

In corrosion control testing there are many instances where we may want to know how much current is flowing including:

- Current output from a rectifier
- Current output from a galvanic anode bed
- Current flow through an interference bond
- Current flow across a bonded electrical isolation device
- Current flow on a pipeline
- Test current for performing tests like a resistance test

In corrosion control testing there are a several methods that can be used to measure current including:

- Measuring the voltage across a shunt and calculating current using Ohm's Law
- Measuring the voltage across a pipeline span and calculating current using Ohm's Law
- Using an ammeter
- Using a clamp-on ammeter

Measuring Current with a Shunt

The most common way that corrosion testers measure current is by using a shunt. A shunt is a resistor that has a known, constant resistance value. Shunts are installed at rectifiers, bonds and other locations so that current can be measured without opening the circuit.

To determine current flow through a shunt, the voltage across the shunt is measured and the current is calculated using Ohm's Law or a "Shunt Factor". A Shunt Factor is a rearrangement of Ohm's Law which simplifies the calculation of current.

The current direction is determined by the polarity of the measurement. Current flows from + to -. If the measurement is positive, the current is flowing from the positive meter connection toward the negative meter connection.

Figure 6-8 shows some common shunts.

To calculate current through a shunt using Ohm's Law:

- Measure the voltage across the shunt, typically in millivolts.
- Convert the voltage from millivolts to volts.
- Calculate the current using this form of Ohm's Law: $I = E/R$, where R is the resistance of the shunt in ohms.

For example, see Figure 6-9:

Voltage across shunt = 21.3 mV

Resistance of shunt = 0.005 Ω

Convert mV to V, 21.3 mV = 0.0213 V

Apply Ohm's Law: $I = E/R = 0.0213 \text{ V} / 0.005 \Omega = 4.26 \text{ A}$



Cathodic Protection Shunts
Figure 6-8

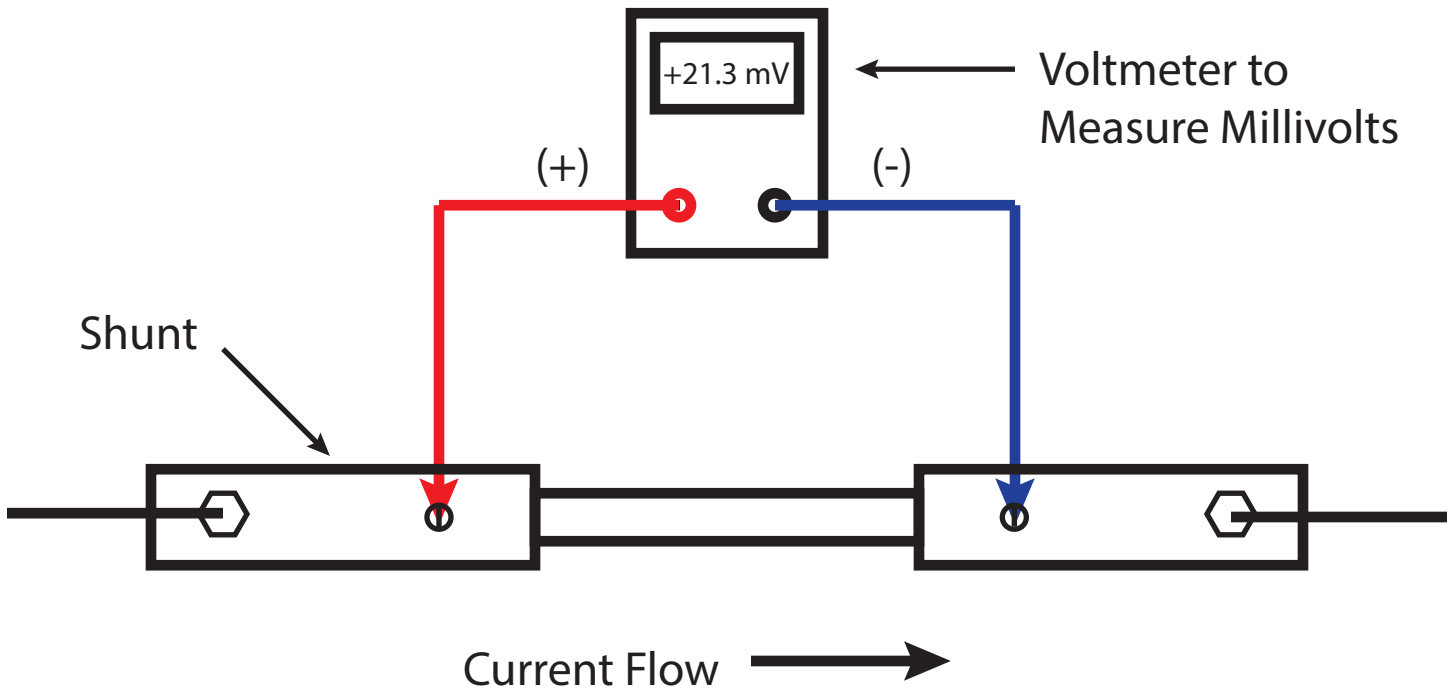

If resistance of shunt = 0.005 Ω :

$$I = \frac{E}{R} = \frac{0.0213 \text{ V}}{0.005 \Omega} = 4.26 \text{ A}$$

Measuring Current with a Shunt Using the Shunt Resistance
Figure 6-9

A simpler way to calculate current through a shunt is to use a shunt factor. A shunt factor is a rearrangement of Ohm's Law that simplifies calculating current from the millivolt reading. A shunt factor is in units of A/mV. It is calculated by dividing the current rating of the shunt by its millivolt value. Most cathodic protection shunts have a millivolt value of 50 mV. Some shunts have their rating and value stamped on them.

For example, see Figure 6-10:

Current rating of shunt = 10 A

Millivolt value of shunt = 50 mV

Shunt Factor = $10 \text{ A} / 50 \text{ mV} = 0.2 \text{ A/mV}$

$I = E\text{-mV} \times \text{Shunt Factor} = 21.3 \text{ mV} \times 0.2 \text{ A/mV} = 4.26 \text{ A}$

Measuring Current Flow on a Pipeline

Current flow on a pipeline can be determined by measuring the voltage drop across a pipe span and calculating the current using Ohm's Law. In effect, we are using the pipe as a shunt.

In order to determine the resistance of the pipe span we can either estimate it using a pipe resistance table or by measuring it directly.

In order to estimate the resistance of a pipe span using a pipe resistance table we need to know:

- The length of the pipe span
- The size of the pipe
- The wall thickness of the pipe

Table 6-1 shows the resistance per foot for various steel pipes.

Figure 6-11 shows the connections for measuring the voltage drop across a pipe span. The arrow on the pipeline indicates the direction of current flow for the instrument polarity shown. As with a shunt, the current direction is determined by the polarity of the measurement. Current flows from + to -. If the measurement is positive, the current is flowing from the positive meter connection toward the negative meter connection.

For example, see Figure 6-11. We measure 2.36 mV across a 100-ft. span of 12-inch, 0.375" WT (wall thickness) pipe.

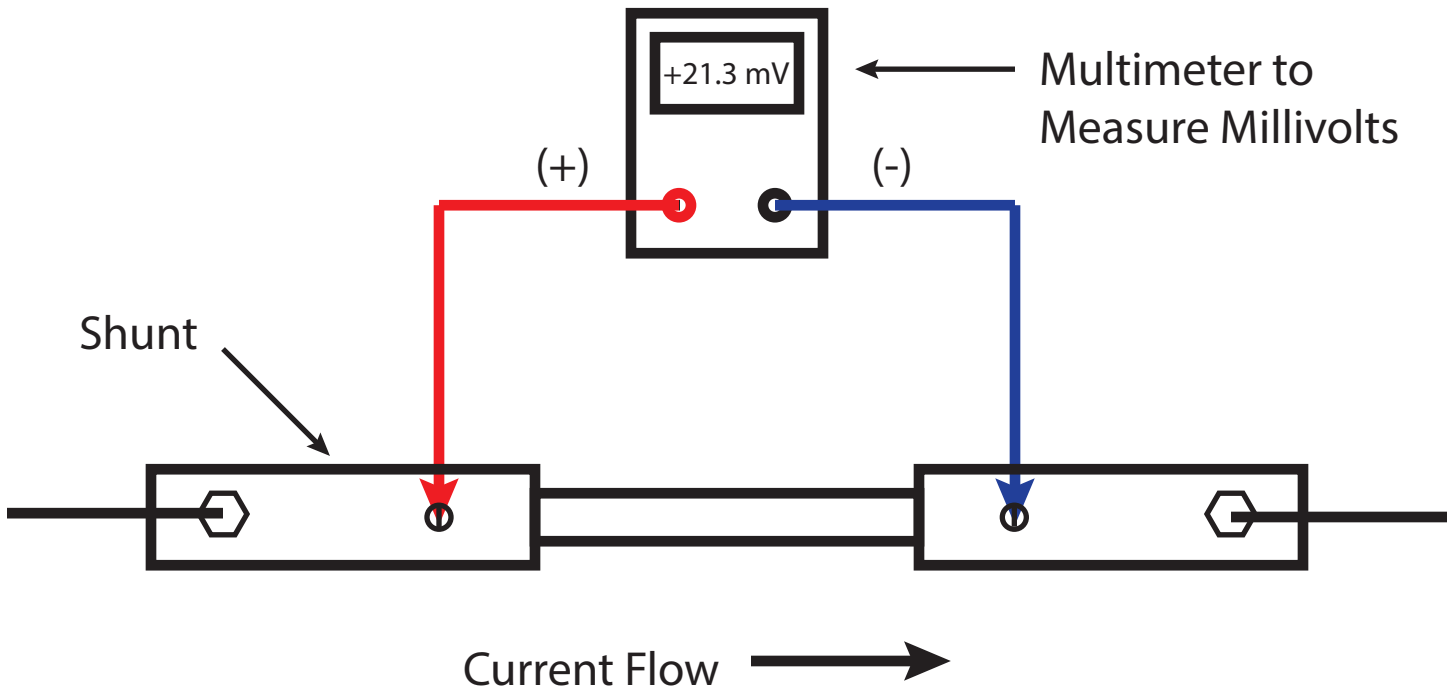

Current rating of shunt = 10 A
 Millivolt value of shunt = 50 mV
 Shunt factor = $10\text{A}/50\text{ mV} = 0.2\text{ A/mV}$

 $I = E \times \text{Shunt Factor} = 21.3\text{ mV} \times 0.2\text{ A/mV} = 4.26\text{ A}$

Measuring Current with a Shunt Using a Shunt Factor
Figure 6-10

TABLE 7-1**RESISTANCE OF STEEL PIPE⁽¹⁾**

Nominal Pipe Size (in)	Outside Diameter (in)	Wall Thickness (in)	Weight per Linear Foot ⁽²⁾ (lbs)	Resistance per Linear Foot ⁽³⁾ ($\mu\Omega$)
2	2.375	0.154	3.65	79.2
4	4.5	0.237	10.8	26.8
6	6.625	0.280	19	15.2
8	8.625	0.322	28.6	10.1
10	10.75	0.365	40.5	7.13
12	12.75	0.375	49.6	5.82
14	14	0.375	54.6	5.29
16	16	0.375	62.6	4.61
18	18	0.375	70.6	4.09
20	20	0.375	78.6	3.68
22	22	0.375	86.6	3.34
24	24	0.375	94.6	3.06
26	26	0.375	102.6	2.82
28	28	0.375	110.6	2.62
30	30	0.375	118.7	2.44
32	32	0.375	126.6	2.28
34	34	0.375	134.6	2.15
36	36	0.375	142.6	2.03

(1) From "Control of Pipeline Corrosion", NACE, 1967, Peabody.

(2) Based on steel density of 489 lbs/ft³.

(3) Using 18 $\mu\Omega$ -cm resistivity for steel:

$$\begin{aligned}
 R &= (16.061 \times 18 \mu\Omega \text{-cm}) / \text{weight per foot in pounds} \\
 &= 289.1 / \text{weight per foot} \\
 &= \text{resistance of one foot of pipe in } \mu\Omega
 \end{aligned}$$

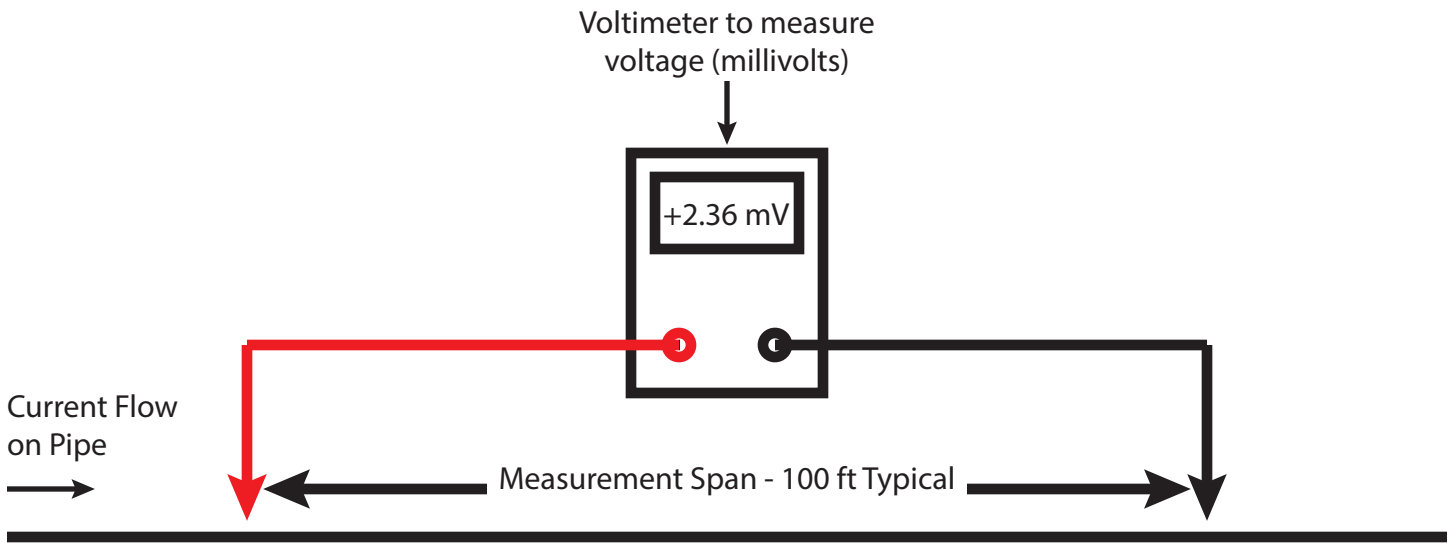

$$I = \frac{E}{R} = \frac{0.00236 \text{ V}}{0.000582 \Omega} = 4.055 \text{ A}$$

Measuring Current Flow on a Pipeline
Figure 6-11

First, we need to calculate the resistance of the span. Looking at Table 6-1, a 12-inch, 0.375" WT pipe has a resistance of 5.82 micro-ohms per foot. For a 100 ft. span:

$$R = 100 \text{ ft.} \times 5.82 \text{ micro-ohms/ft} = 582 \text{ micro-ohms}$$

$$582 \text{ micro-ohms} = 0.000582 \text{ ohms}$$

$$2.36 \text{ mV} = 0.00236 \text{ V}$$

$$\text{Apply Ohm's Law: } I = E/R = 0.00236 \text{ V}/0.000582 \text{ ohms} = 4.055 \text{ A}$$

A more accurate way to determine the resistance of a pipe span is to measure it. In order to measure the resistance across a pipe span there must be 4 wires with 2 wires at each end of the span as shown in Figure 6-12. Figure 6-12 shows the connections for measuring the resistance of a pipe span. As in the previous example, a voltmeter is connected to measure the voltage across the span. A current circuit is set up across the span with a battery and ammeter. When the current circuit is closed the test current will flow through the span and cause the voltage across the span to change.

Rather than calculating the span resistance in ohms, it is simpler to determine a calibration factor (K factor) in units of amps per millivolt (A/mV) like we do with shunts. For example, see Figure 6-12. Assume that a test current of 10.8 amperes is connected across the span and changes the voltage across the span from 2.36 millivolts to 7.31 millivolts. The calibration factor will be:

$$K = I/\Delta E = 10.8 \text{ A}/(7.31 \text{ mV} - 2.36 \text{ mV}) = 2.182 \text{ A/mV}$$

After we have determined the K Factor, we can use this value to calculate the amount of current flowing on our pipeline. For example, when we started testing, we measured 2.36 mV across our span. Therefore, the amount of current flowing is:

$$I = K \text{ factor} \times E\text{-mV} = 2.182 \text{ A/mV} \times 2.36 \text{ mV} = 5.15 \text{ A}$$

When calibrating a pipe span it is critical that there be 2 wires at each end of the span so that the voltage and current connections to the pipe are separate. Using the same test wire for voltage and current will create a significant voltage across the wire which will be included in the voltage measurement rendering it invalid.

Pipe spans used to measure current can be any length, but the resistance of the span needs to be high enough to allow measurement of the pipeline current with acceptable accuracy. A small amount of current flowing across a short span may not be measurable.

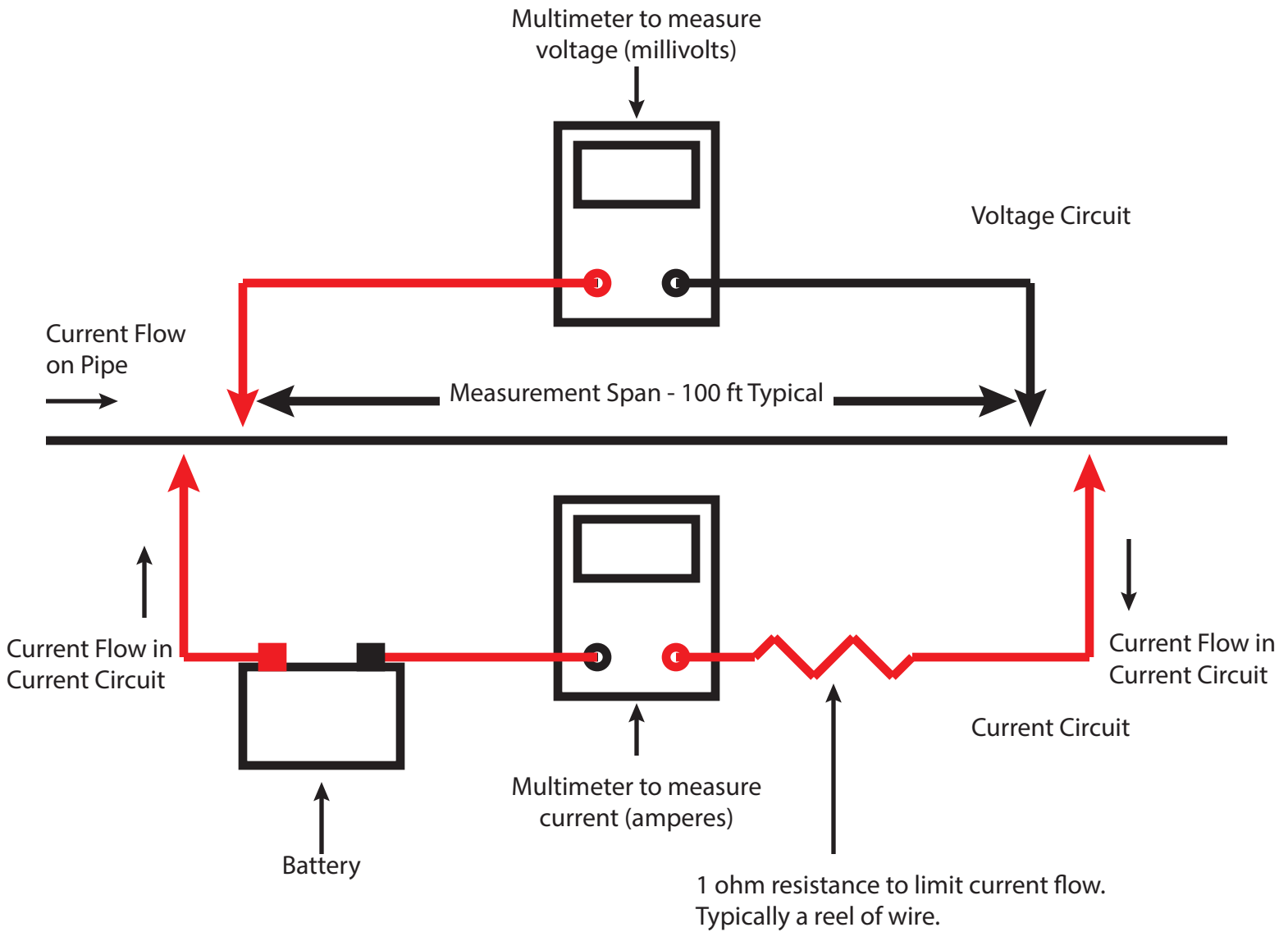

$$K = \frac{I}{E_{ON} - E_{OFF}} = \frac{10.8 \text{ A}}{7.31 \text{ mV} - 2.36 \text{ mV}} = 2.182 \text{ A/mV}$$

$$I \text{ as found} = 2.36 \text{ mV} \times 2.182 \text{ A/mV} = 5.15 \text{ A}$$

Calibrating a Current Measurement Pipe Span

Figure 6-12

Measuring Current with an Ammeter

An ammeter can also be used to measure current. Most multimeters include an ammeter.

In order to measure current with an ammeter you must break the circuit and install the ammeter in the circuit so that the current to be measured flows through the ammeter.

Within the ammeter, the current is flowing through an internal shunt. The meter measures the voltage across the shunt and displays current.

The primary drawback of this method is that the circuit must be opened, and the ammeter inserted in it.

An ammeter is used to measure current in circuits where a shunt has not been installed such as galvanic anode beds or bonded electrical isolation devices. Figure 6-13 shows an ammeter being used to measure galvanic anode current and current across a bonded electrical isolation device.

As with a shunt, the current direction through an ammeter is determined by the polarity of the measurement. Current flows from + to -. If the measurement is positive, the current is flowing from the positive meter connection toward the negative meter connection.

Ammeters are also used to measure test current that is used for performing tests like resistance tests.

Clamp-On Ammeters

Another way to measure current flow on a conductor such as a pipe or cable is with a clamp-on ammeter. A clamp-on ammeter has a sensor in the form of a clip or clamp. When the sensor is placed around a conductor, the ammeter will indicate the current flow on it. Current quantity and direction will be indicated.

Small sensors are in the form of clips or “jaws”. The clips are squeezed open and placed around the conductor. The clips are then released so that they close. The ammeter will then indicate the current flow on the conductor within the sensor. The sensor may be integrated into the ammeter or may be separate from the ammeter and connected to it with test leads. Sensors in the form of clips are available for use on conductors up to 6 inches in diameter.

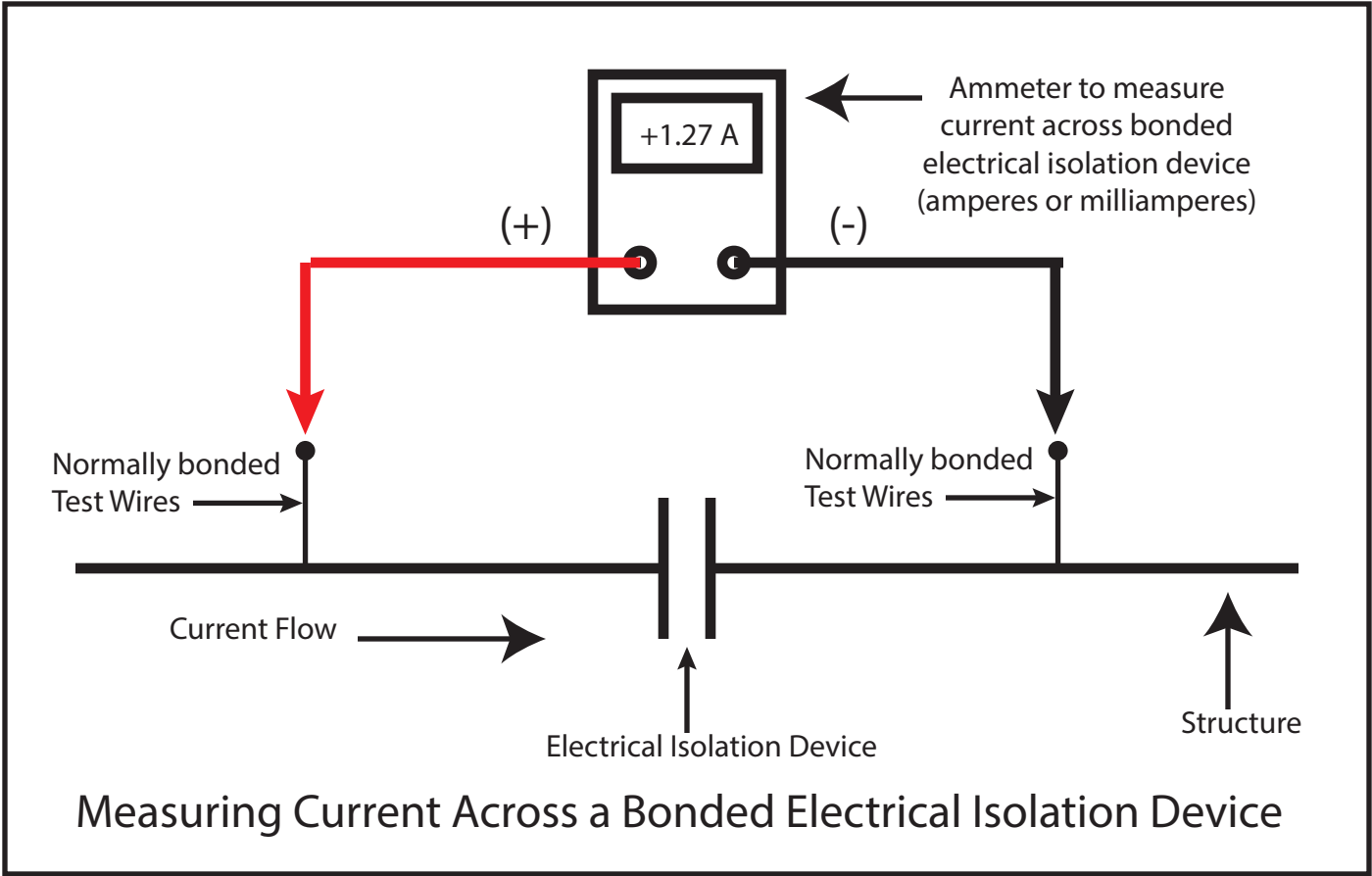
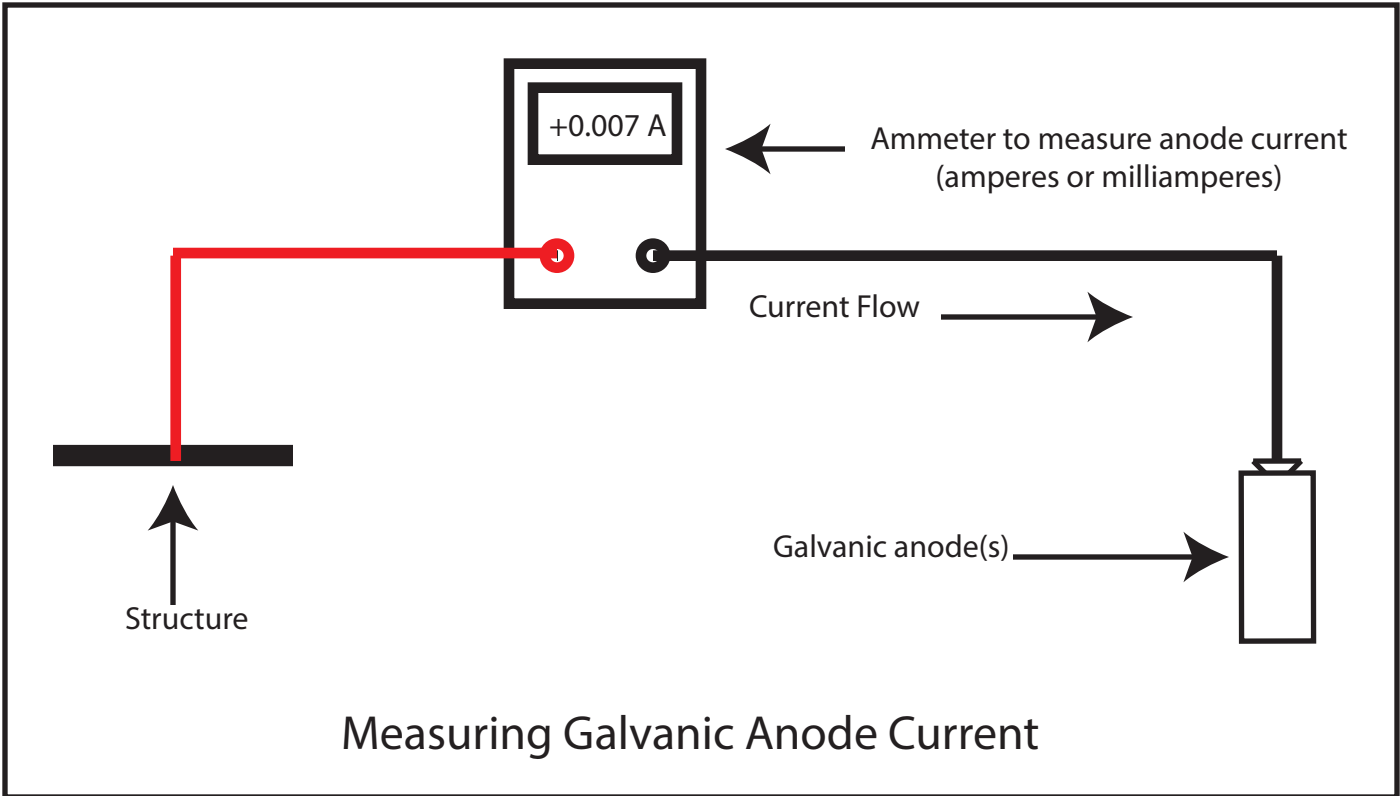

Measuring Current with an Ammeter
Figure 6-13

Large sensors are in the form of 2- or 4-piece clamps that are assembled around the conductor. The assembled sensor is connected to the ammeter with test leads. The ammeter will then indicate the current flow on the conductor within the sensor. Large sensors are available for use on conductors up to 82 inches in diameter.

The sensors may be permanently installed around a buried or submerged pipeline and their test leads terminated in a test station so that current flow can be monitored.

It is important to note that clamp-on ammeters measure the net current within the sensor. If 2 conductors are placed within the sensor, the ammeter will indicate the sum of the current flow on the 2 conductors. For example, if the sensor is placed around both the positive and negative leads from a rectifier, the ammeter will indicate 0, since the current on the 2 cables is in opposite directions.

Figure 6-14 shows a clamp-on ammeter measuring current flow on a stainless steel tubing line. In this example, the tubing line was installed across an isolating flange.



**CLAMP-ON AMMETER MEASURING CURRENT
ON STAINLESS STEEL TUBING**

FIGURE 6-14

Chapter 7 – Rectifier Basics

INTRODUCTION

A rectifier is a device that converts alternating current (AC) electricity from the power grid to direct current (DC) electricity for impressed current cathodic protection.

This chapter will discuss the basic operation and monitoring of cathodic protection rectifiers including:

- Rectifier safety
- Rectifier components
- Types of rectifiers
- Periodic inspections of rectifiers
- Preventive maintenance of rectifiers
- Basic troubleshooting of rectifiers
- Interrupting rectifiers

RECTIFIER SAFETY

Before we proceed, let's discuss safety around cathodic protection rectifiers.

Cathodic protection rectifiers can pose electrical shock and arc flash hazards. Only qualified personnel should access cathodic protection rectifiers. Most companies have developed safety procedures for personnel accessing cathodic protection rectifiers. Qualified personnel accessing cathodic protection rectifiers must follow appropriate safety procedures. Not all personnel may be qualified to perform all the tasks described in this text.

Many companies require that personnel accessing freestanding rectifier installations check the rectifier case to confirm it is not energized before accessing it. This can be done by using a non-contact voltage detector or by measuring the rectifier case-to-soil voltage with a voltmeter and a CSE. When measuring the rectifier case-to-soil voltage, the voltmeter connection to the case must be made with an insulated clip or probe. If the case-to-soil voltage is less than 15 VAC and 15 VDC it is safe to access.

At one point in time it was common practice to check to see if the case was energized by "backhanding" the rectifier. This practice is no longer considered acceptable.

RECTIFIER COMPONENTS

What is a rectifier?

As stated previously, a rectifier is a device that converts alternating current (AC) electricity from the power grid to direct current (DC) electricity for impressed current cathodic protection.

The positive terminal of the rectifier is connected to the anode bed. The negative terminal of the rectifier is connected to the protected structure. Connecting a rectifier with the opposite polarity will cause the structure to corrode rapidly and could have catastrophic consequences.

A standard cathodic protection rectifier is a simple electrical device. The heart of the rectifier consists of the transformer and the rectifying element. These two components alone could provide the DC power required for a cathodic protection system. Other components, or accessories, are added to the unit to enhance its performance and provide safety functions.

Transformer

A transformer is a device used to step up a voltage, step down a voltage, or to isolate a voltage from its source. In a rectifier, the transformer is used to step down the voltage from the power source to a suitable voltage for rectification. In most rectifiers, the voltage output of the rectifier is adjusted by changing the tap settings of the transformer.

Rectifying Element

The rectifying element is an array of diodes that converts the AC in to DC out. A diode is a two-terminal electronic component that conducts current primarily in one direction. By arranging multiple diodes in the proper configuration, the AC into the array will be converted to DC. The most common rectifying circuit is the single-phase bridge. The DC produced will not be pure DC, like from a battery, but rippled. See Figure 7-1.

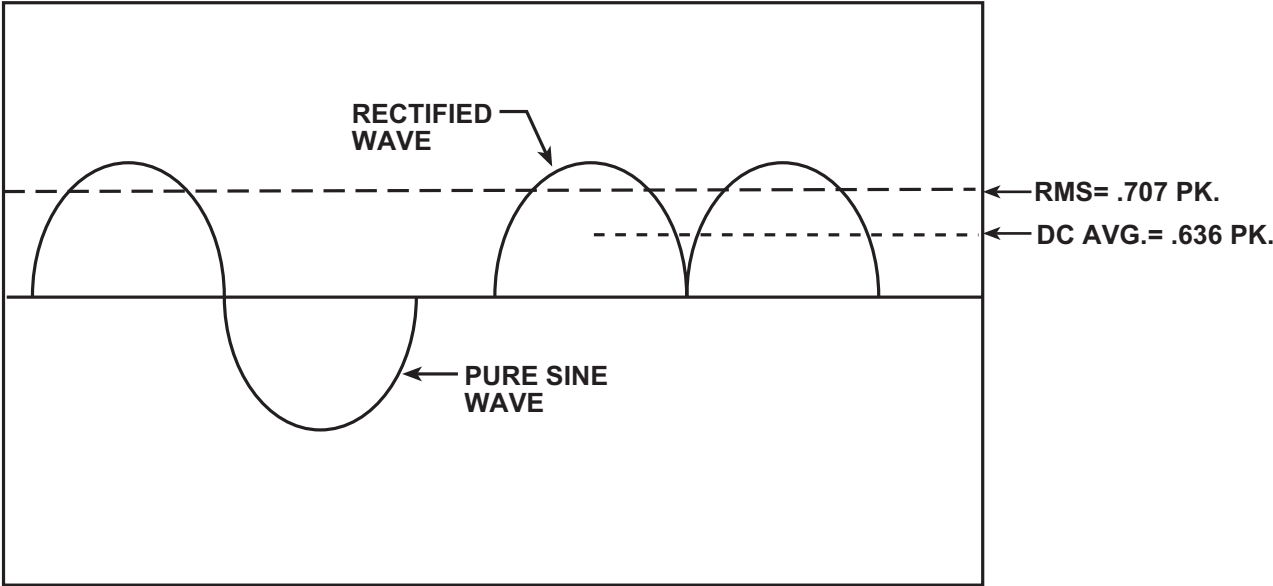

Most recently built rectifiers use silicon diodes. At one point in time selenium bridges were the preferred rectifying element in cathodic protection rectifiers. Selenium bridges, while common in the 1960's and 1970's have declined in usage in the industry. During those times, silicon devices were more susceptible to damage from spikes/surges, while selenium was more durable. The drawback is that selenium as a bridge "ages" and declines in efficiency over time, while silicon bridges do not. Improvements in the peak inverse voltage/peak reverse voltage (PIV/PRV) ratings of silicon diodes have made them stronger and more durable. Additionally, improvements in grounding and lightning protection have also contributed to silicon being a better choice for continued efficiency and more durable operation

Some rectifying elements have multiple discreet diodes. For lower output rectifiers, one-piece silicon diode bridge rectifier modules can be used.

Circuit Breakers

The primary function of a circuit breaker is to provide overload protection for the circuit in which it is installed. In a rectifier, the built-in breaker also serves as the on-off switch for the unit.

In most rectifiers, turning off the built-in breaker will de-energize components on the rectifier panel such as the output terminals, the shunt, fuse holders and the transformer taps. It will not de-energize all components in the rectifier. To de-energize all components, an external disconnect must be used. It is good practice to have an external disconnect installed near the rectifier.

Shunts

Almost all rectifiers have shunts to allow a simple way to measure the DC current output.

Accessory Equipment

Optional equipment such as indicating meters, lightning arresters, fuses or breakers, efficiency filters and communications filters can also be supplied with the rectifier unit.

Voltmeters and ammeters are commonly installed on the rectifier to facilitate the monitoring of its voltage and current output. Sometimes, only one meter is supplied which, by use of a selector switch, will read both volts and amperes. Built-in voltmeters and ammeters should not be considered accurate or reliable. Portable multimeters should be used to obtain accurate voltage and current output values.

Lightning arresters are normally installed on both the AC input and the DC output circuits of the rectifier. Lightning surges can enter the rectifier from both the AC and DC sides. Installation of lightning arresters will help prevent damage to the unit and its components due to these surges.

In addition to the main breaker, fuses or breakers can be installed in the positive and negative DC output circuits and the AC secondary circuit.

Efficiency filters can be added to some rectifying elements to improve the AC to DC conversion efficiency and save power costs.

Communications filters can be used to eliminate electronic noise/interference on electronic circuits and at the same time provide increased lightning protection to the DC circuits of the unit.

TYPES OF RECTIFIERS

Air Cooled Rectifiers

This type of rectifier and its components are enclosed in a steel enclosure with doors that provide access to the unit for testing and repairs. The bottom of the enclosure is usually constructed of steel screening to allow for the circulation of air. This type of unit can either be wall, pole, or pedestal mounted depending on the size and weight of the unit. See Figure 7-2.

Oil Cooled Rectifiers

This type of rectifier is used in areas where dust, salt air, corrosive fumes or excessive moisture may shorten the operating life of an air-cooled unit. The rectifier and its components are installed in a steel enclosure and are completely immersed in oil,

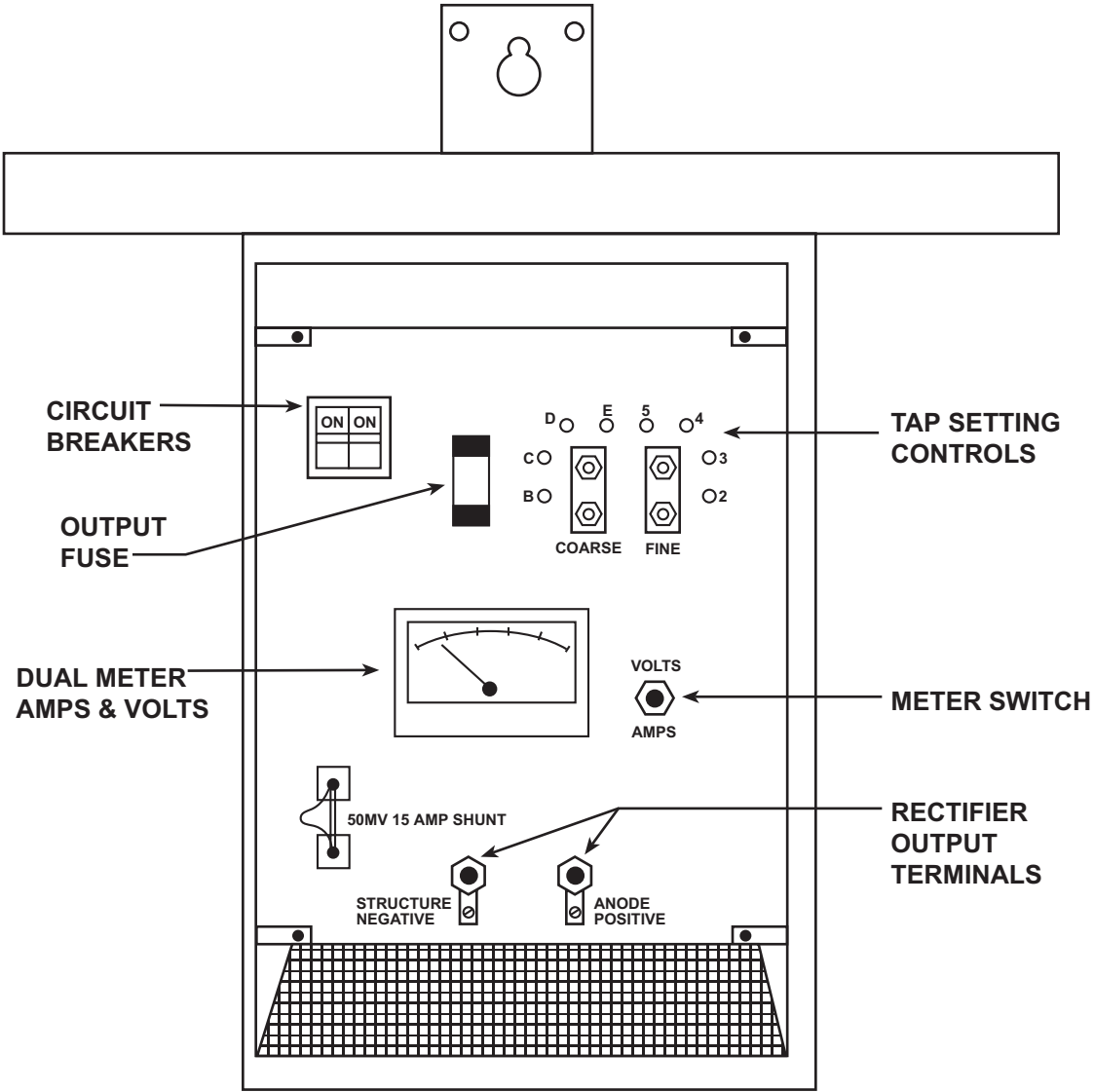

CIRCUIT BREAKERS

OUTPUT FUSE

DUAL METER AMPS & VOLTS

TAP SETTING CONTROLS

METER SWITCH

RECTIFIER OUTPUT TERMINALS

50MV 15 AMP SHUNT

STRUCTURE NEGATIVE

ANODE POSITIVE

VOLTS
AMPS

D O E 5 O4
CO BO COARSE FINE
O3 O2

isolating them from extreme environments. Oil cooled rectifiers are normally pedestal mounted due to their weight. See Figure 7-3 for a typical oil cooled rectifier detail.

Explosion Proof Rectifiers

Modified oil cooled rectifiers are available with explosion proof fittings. These explosion proof rectifiers are suitable for use in areas where explosive or flammable vapors, liquids or powders are present.

Constant Current Rectifiers

Constant current rectifiers have a special circuit that enables them to provide a nearly constant current output regardless of circuit resistance. This type of rectifier is used in applications where the circuit resistance changes drastically and the output current would be exceeded with a normal rectifier. A rectifier having an anode bed installed in a tidal location is an example of a place a constant current rectifier might be used.

Automatic Potential Controlled Rectifiers

Automatic potential controlled rectifiers monitor the structure-to-electrolyte potential and maintains it at a desired level. The use of this type of rectifier requires the use of a permanently installed reference electrode and an additional test wire connection to the structure. Both are connected to a transistorized control circuit as shown in Figure 7-4. The controller adjusts the output voltage to keep the reference cell potential at a preset level. Automatic potential controlled rectifiers are very useful in the control of corrosion on structures such as water storage tanks, harbor structures and structures affected by dynamic stray currents.

PERIODIC RECTIFIER INSPECTIONS

Inspecting Rectifiers

In order to insure proper operation, rectifiers must be inspected on a regular basis. Rectifiers that are subject to PHMSA regulations must be inspected at least six times each year with no more than 2½ months between inspections to insure the units are operating properly. Inspecting a rectifier at least every 2 months is a good practice even if it is not subject to any regulations.

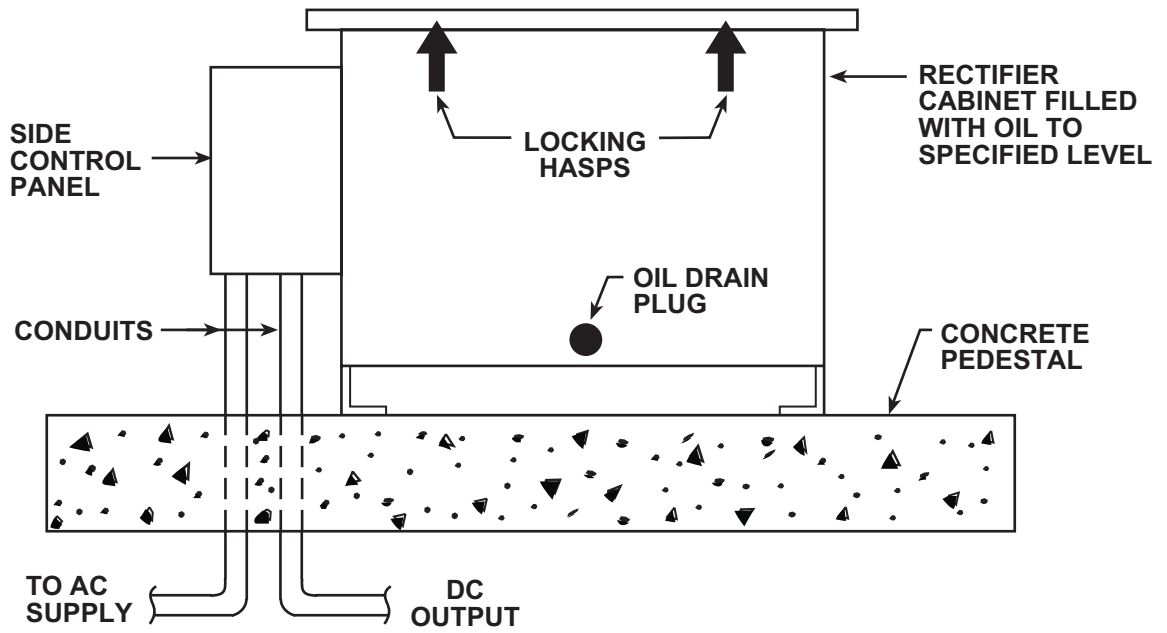

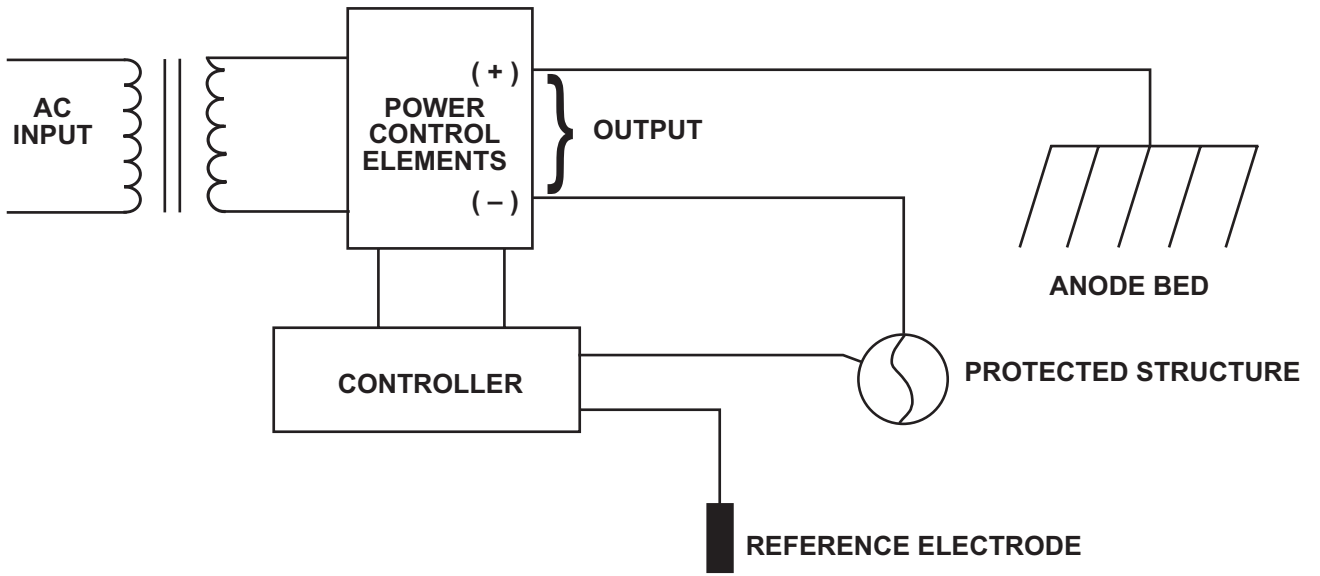

A routine inspection of a rectifier should include, at the least, measuring and recording the DC voltage and current output of the unit. These values can be determined by reading the built-in voltmeter and ammeter, but it is more reliable to use a portable voltmeter.

Remote Monitoring of Rectifiers

Rectifiers can also be fitted with remote monitoring units (RMUs). RMUs are devices that will measure the operating parameters of a rectifier and allow that information to be accessed remotely. RMUs are available in radio, satellite and cellular communication configurations. Some systems allow the measurement data to be accessed through an internet web interface. Some systems will send notification of rectifier operating anomalies by email or text messaging.

Prior to Touching Rectifier Case

Follow your company's safety procedures before opening the rectifier. This may include checking to see if the case is energized as described previously.

Before accessing a rectifier, perform a visual check of the rectifier. Look for unusual conditions such as loose wires, scorch marks or holes in the case. Look for insects, rodents and other wildlife. Note any unusual smells or sounds that may indicate an issue with the rectifier. When opening the rectifier, take appropriate care based on your observations. If your observations suggest it may not be safe to access the rectifier, contact your supervisor for guidance before proceeding.

Measuring Rectifier Voltage

The DC voltage output is determined by measuring the DC voltage between the rectifier output terminals with a voltmeter. Set the voltmeter to volts DC. Connect the positive lead of the voltmeter to the positive output terminal of the rectifier. Connect the negative lead of the voltmeter to the negative output terminal of the rectifier. Use insulated clips or probes to avoid skin contact with the terminals. See Figure 7-5.

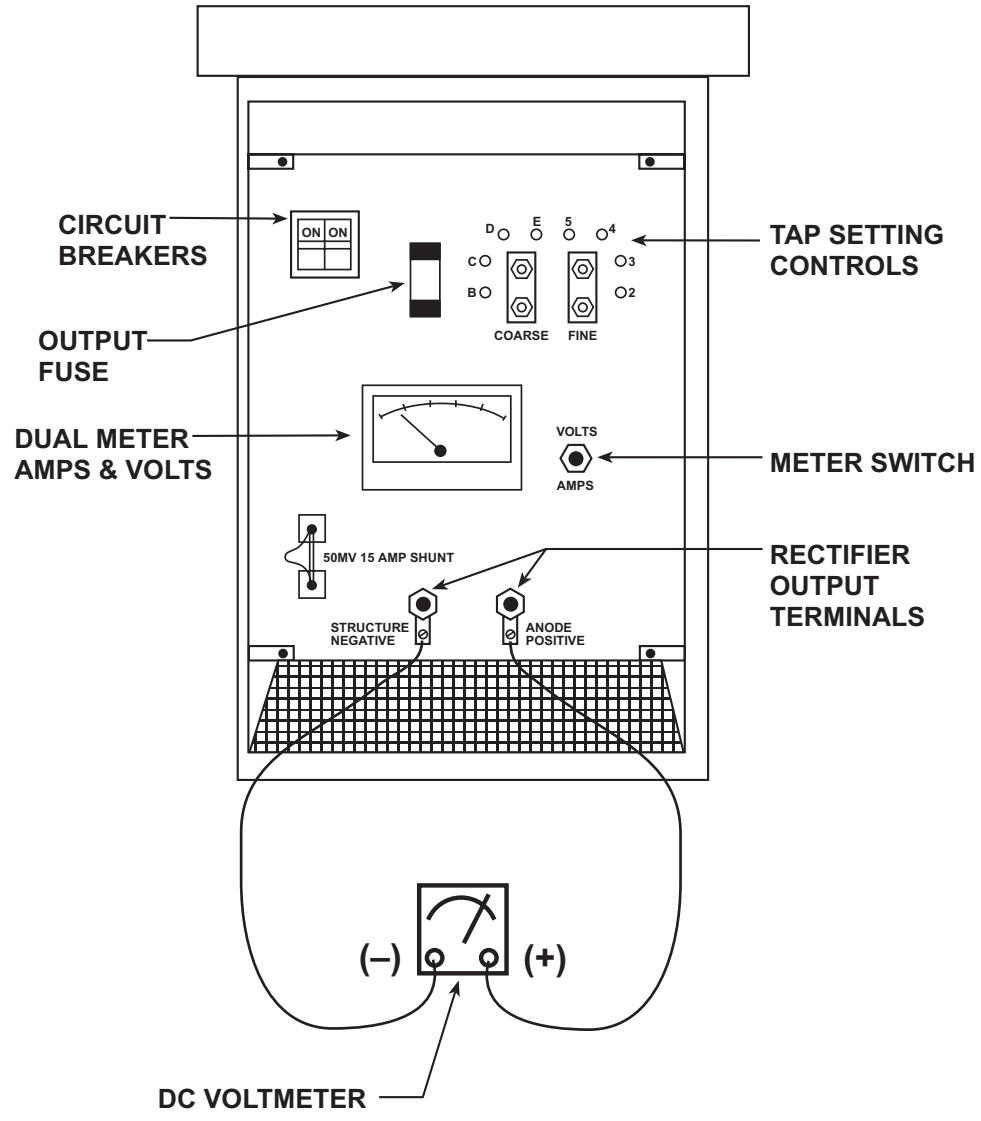

Measuring Rectifier Current

The DC current output is best determined by measuring the DC voltage across the rectifier shunt. Set the voltmeter to millivolts DC. Connect one lead of the voltmeter to one side of the shunt. Connect the other lead of the voltmeter to other side of the shunt. Make the connections to the measurement screws or tabs, not the mounting bolts. Use insulated clips or probes to avoid skin contact with the shunt. See Figure 7-6. Calculate the current output by multiplying the measured millivolts by the shunt factor as we learned in Chapter 6.

The rectifier current output can also be measured by inserting an ammeter in either the DC positive or negative cable. However, this requires that the rectifier be shut off, one of the cables disconnected, and the ammeter inserted in the circuit.

The rectifier current output can also be measured by using a clamp-on ammeter.

Using the rectifier shunt is the simplest and most accurate way to measure the current output of a rectifier.

Preventive Maintenance

When inspecting a rectifier, if qualified, you should also:

- Remove insect and rodent nests and plug any holes through which insects or rodents can enter the rectifier.
- Clean all ventilating screens in air-cooled units so that airflow will be completely unobstructed.
- Remove excessive dirt and dust accumulations.
- For oil cooled rectifiers, check the oil level and condition. The oil should be clear and nearly colorless. Failing oil is usually characterized by a murky or cloudy appearance with loss of transparency and should be replaced. Facilities are available for testing the oil and salvaging it by filtration where practical.
- Inspect all components, including lightning arresters, for signs of lightning damage – arc traces across insulators or panels; or discolored parts. If their

TWO METHODS:

- 1. DC AMMETER IN SERIES WITH ONE OF THE DC LEGS.
CURRENT READ DIRECT IN AMPERES.**
- 2. DC MILLIVOLTMETER IN PARALLEL WITH PANEL SHUNT.
RATING OF SHUNT WILL USUALLY BE STAMPED INTO THE SHUNT.**

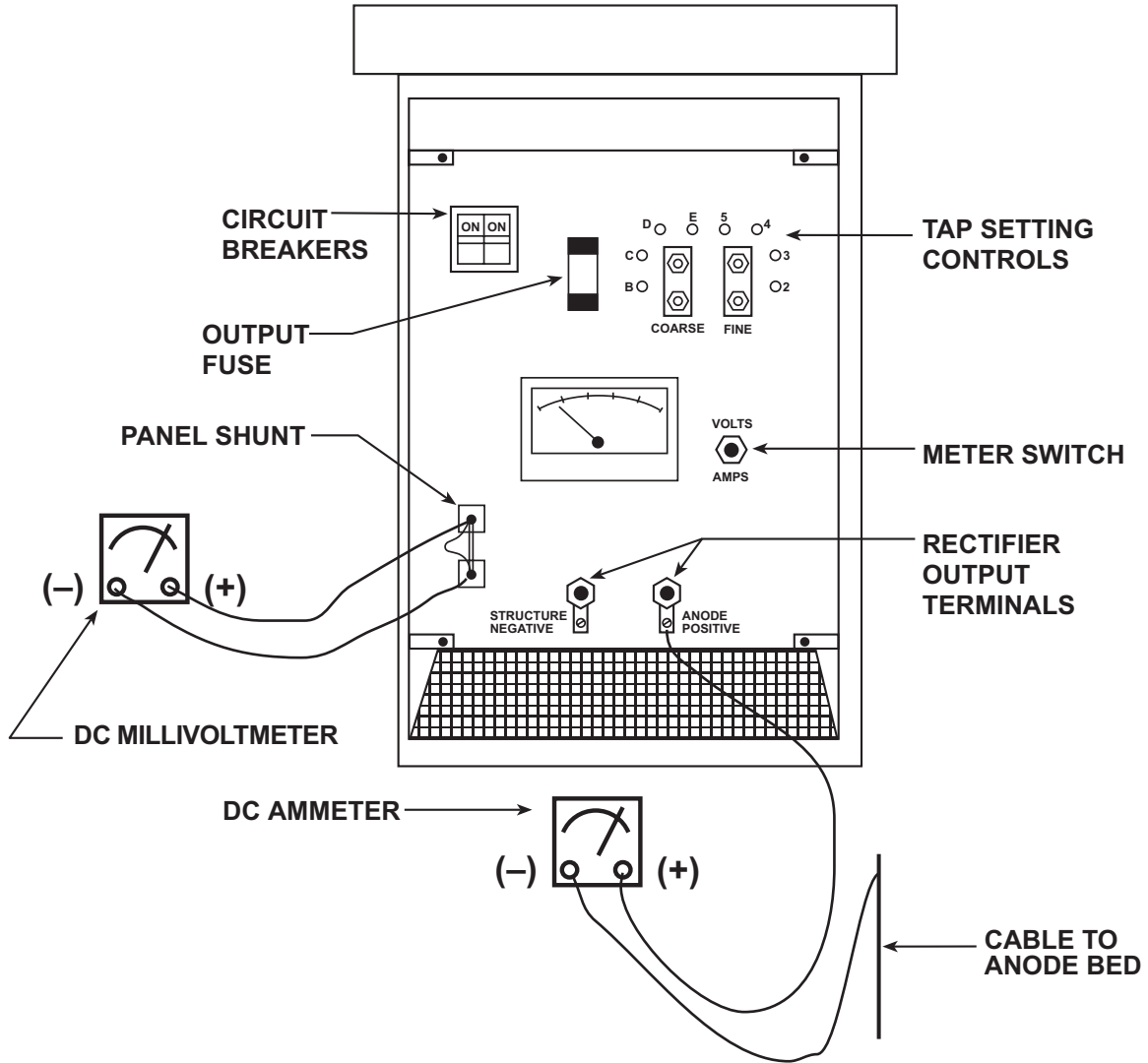

appearance has been altered or if damage is suspected, the component should be replaced.

- Replace all wires on which the insulation has been damaged.

Basic Troubleshooting

If a rectifier is found to be off, check to see if the cause is a blown fuse or a tripped circuit breaker. These are the two most common causes of rectifier malfunctions. If this is the case, resetting the breaker or replacing the fuse may be all that is required to restore the rectifier to operation.

If you cannot restore the rectifier to operation by resetting breakers or replacing fuses, notify appropriate personnel so that additional troubleshooting can be performed.

INTERRUPTING A RECTIFIER

When measuring structure-to-electrolyte voltages on an impressed current cathodic protection system it is common practice to cycle the rectifier on and off. This is commonly referred to as interrupting the rectifier and is done by installing a current interrupter in the rectifier. A current interrupter is an automated switch that opens and closes a circuit in the rectifier so that the DC current output is alternately on and off. Different on and off cycles are used so they can be distinguished from each other. When testing a protected structure, the on cycle should be at least 3 times longer than the off cycle so as not to lose polarization.

Some remote monitoring systems (RMUs) include a current interrupter circuit that can be activated remotely.

If there are multiple rectifiers protecting a single structure, multiple synchronized interrupters are used so that they are all on and off simultaneously. The interrupters can be synchronized by GPS. All RMU interrupters and some portable interrupters can be synchronized by GPS.

An interrupter can be installed in:

- The positive DC output cable
- The negative DC output cable

- A transformer tap
- The AC input (see cautionary note below)

In order to install a current interrupter in the positive or negative DC output cable:

- Shut the rectifier off
- Remove the desired cable from the rectifier terminal
- Connect one side of the interrupter to rectifier terminal
- Connect the other side of the interrupter to the cable
- Turn the rectifier back on.
- See Figure 7-7

In order to install a current interrupter in a transformer tap:

- Shut the rectifier off
- Remove a tap connection by removing a tap bar or disconnecting a screwed tap connection. Either the coarse or fine tap can be used.
- Connect the 2 sides of the interrupter across the open tap connection.
- Turn the rectifier back on.
- Note: if the structure has induced AC on it the DC output may not go to zero when interrupting a transformer tap.
- See Figure 7-7

In order to install a current interrupter in the AC input:

- Installing an interrupter in the AC input should only be done by qualified personnel.
- Installing an interrupter in the AC input is typically only done with RMUs that have current interrupting capabilities, not with portable interrupters.

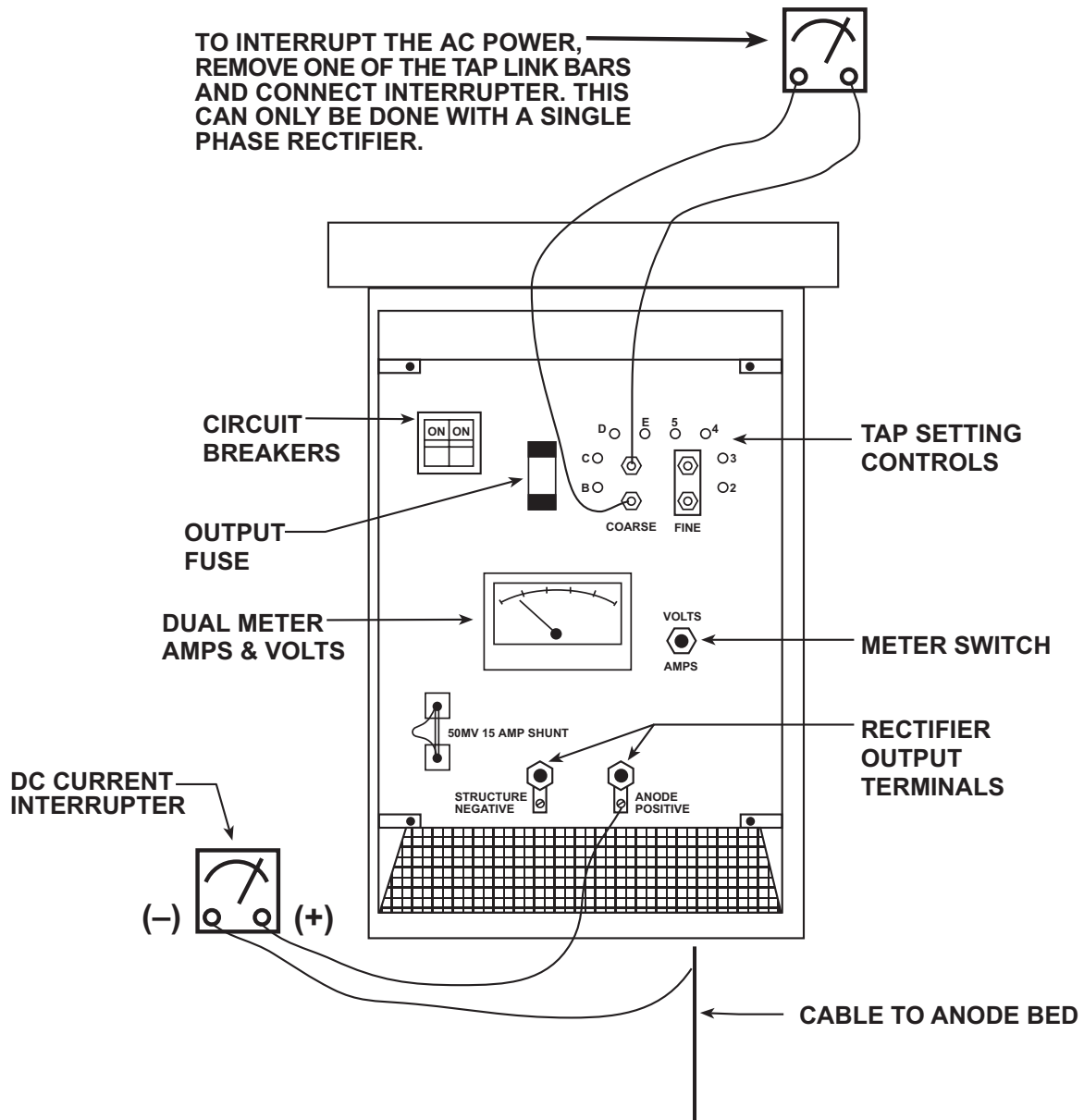

INSTALLATION OF THE CURRENT INTERRUPTER AT EITHER THE AC TAPS OR IN A DC LEG WILL INTERRUPT THE DC CURRENT OUTPUT.

RECORD THE RECTIFIER CURRENT OUTPUT WITH AND WITHOUT THE INTERRUPTER IN THE CIRCUIT.

AUCSC Basic Course Chapter 8 Regulatory Compliance

Prepared for AUCSC by
Mary S. Friend
Public Service Commission of West Virginia



1

Regulatory compliance describes the goal that organizations aspire to achieve in their efforts to ensure that they are aware of and take steps to comply with relevant laws and regulations.

2

Regulatory Compliance

- Ensure uniformity across operator pipeline system(s)
 - Written procedures
 - Training and qualification
 - Records

3

Records – including Corrosion

- Prove compliance with federal and state pipeline safety regulations
- Used to support integrity management
 - Knowledge about the pipeline system
 - Identify threats to the pipeline
 - Risk analysis
 - Preventative or mitigative measures to reduce risk

4

Regulations

- Federal
 - 49 CFR 192 – Natural and Other Gas
 - 49 CFR 193 – LNG Facilities
 - 49 CFR 195 – Hazardous Liquids
- Intrastate operators may be subject to additional state regulations



5

OTHER DOCUMENTS

- Incorporated by reference documents
- PHMSA Code Interpretations, Alert and Advisory Bulletins, and Waivers
- PHMSA Enforcement Actions and Violation Letters
- PHMSA Enforcement Guidance

6

OTHER DOCUMENTS

- GPTC (Gas Piping Technology Committee)
- ASME B31.8
- Association standards not incorporated by reference
 - NACE, ASTM, API

7

Compliance

- Federal regulations are minimum standards
 - Governs operation, maintenance, design and construction
- State regulations may exceed standards
 - Only applicable to intrastate pipelines

8

O&M Procedure Manual

- Part 192, 193, or 195 – Minimum Safety Standards
 - Operators must comply with minimum standards from code
 - Can voluntarily exceed minimum standards in their written
 - If exceeded, become the standard to which an operator is inspected

9

O&M Procedure Manual

§§192.605, 195.402, 193.2503

- Company interpretation and implementation of code
- Provides uniform standard
- First reference on **WHAT** to do
- Auditable procedures

10



11

Inspection Intervals

- Many once per calendar year, not to exceed 15 months
- Six times per year, not to exceed 2 ½ months (75 days)
- Every three calendar years not to exceed 39 months
- To the day
- Can do early, but not late
 - Reset calendar



12

O&M Procedure Manual

**O&M Manual standards
are audit standards and
are enforceable**

13

Be aware of how company
procedures are written

SHALL

versus

SHOULD

Shall is imperative, mandatory,
required, it must be done. Should
allow some wiggle room.

14

**O&M Manual –
Records and History**

Making construction records, maps
and operating history available to
appropriate operating personnel

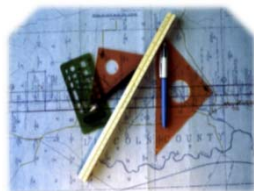
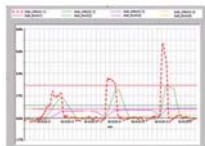

§192.605(b)(3)
§195.402(c)(1)

15

O&M Manual - Corrosion

Controlling corrosion in accordance with the operations and maintenance requirements of SUBPART I (Subpart H) of this part



§192.605(b)(2)
§ 195.402(c)(3)

16

Records

Keep records necessary to administer the procedures



§192.603(b)
§195.404

17

Records

- The regulations do not specify how records are kept.
- They can be electronic, paper, or some other format specified by the operator.
- Some sections specify what needs to be on forms, but not required to be signed, but do need to indicate who did the task.
- Should include what was inspected, who inspected, and date of inspection.

18

NO RECORD = NO WORK

19

Records

- Life of Facility Records
 - Include construction, materials, repairs, MAOP information, and most corrosion records
 - Retained for as long as facility is in service
- Other Records
 - Include tests, inspections, patrols, surveys and procedure reviews which prove compliance with 49 CFR 192, 193, or 195
 - Retain for at least 5 years

20

Records

Records should be:
Complete
Accurate
Accessible

21

Complete Records

- Right form?
- Everything filled out?
 - Blanks mean questions
- Name of person doing task
 - OQ
- Date



22

Accurate

- Information correct
 - Location
 - Stationing
 - GPS
 - Other
 - Readings
 - Materials



23

Accessible

- Paper
- Computerized
- Integrity of the documents
 - Who has access and can change



24

Records

- Retained according to Company procedures
- For records to be accurate they must include:
 - Who performed work? (qualified)
 - When work was performed? (date)
 - What work was performed? (task)
 - Where was work performed? (location)
 - How was work done? (procedure)
 - Results? (readings/inspections)

25

Records

- Retained according to Company procedures
 - What is record keeping system
 - How long is record kept
- Integrity Management has changed some retention intervals

26

Records

- Pipeline information
 - Installation dates
 - Size or diameter, wall thickness, grade
 - Coating
 - Installation method
 - Repairs



27

Records

- Miles of:
 - Bare pipe, coated pipe
 - Cathodically protected pipe
 - Type CP system – impressed current or anodes
 - How many rectifiers
 - Electrical isolation and stray current
 - Number of critical/non-critical bonds
 - Active corrosion zones

28

Corrosion Control Records

- Records or Maps
 - Location of Protected Piping
 - Cathodic Protection Facilities
 - Galvanic Anodes
 - Bonds to Other Structures
 - As built

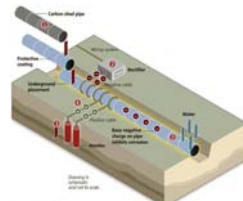

29

Records

- Casings
 - Shorted casings/filled
 - Tests for shorted casings
 - How shorted casings are monitored
- Stray current problems
 - HV power lines
 - Shared ROW's
 - Tests



30

Records

- Other corrosion records

- IR consideration
- Soil resistivity
- Design calculations
- Stray current surveys
- Interference tests
- CIS, DCVG

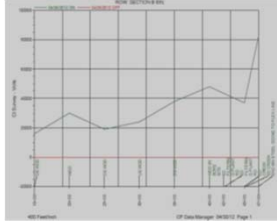

- Remedial actions and mitigation

31

Records

- Leak Reports

- Grading
- Repairs



32

Records

- Buried pipe inspection reports, internal inspection reports

- Actual conditions agree with records?
- Remediation
- Both left in ground and removed
- Circumferentially and longitudinally



33

Records

- Atmospheric inspections
 - Newly exposed pipe
 - Pipe to soil interfaces
 - Under insulation
- Remediation



34

Records - CP

- Rectifier inspection
- Pipe to soil readings
- Critical/non-critical bonds
- IR drop coupons
- Electrical isolation
- Remediation



35

Records - Internal

- Gas samples
- Bacteria cultures
- Water/solid samples
 - pH
- Coupons



36

Records

- Most corrosion records retained 5 years
- Exceptions retained for life of pipeline
 - Annual P/S Surveys
 - 3-Year Reevaluations
 - Inspections for Internal Corrosion
- Retain according to Company policy

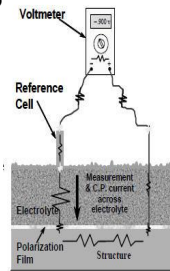

37

Regulatory Compliance

- Achieved through
 - Following detailed written procedures
 - Creating the required records
 - Field observation and verification
- Using information to determine additional actions



38
